

AM 30 AUTO HTP POWER SPRAYER

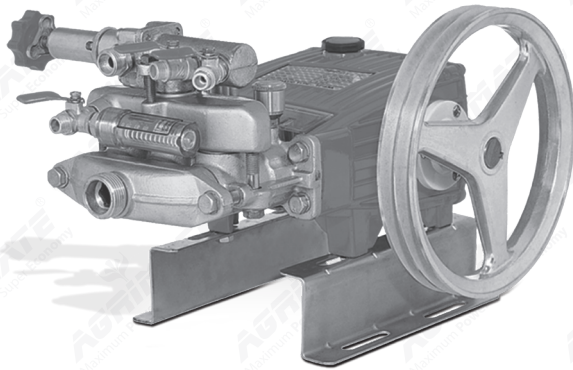

DISCLAIMER: DUE TO CONSTANT UPGRADATION, FEATURES AND SPECIFICATIONS ARE SUBJECT TO CHANGE WITHOUT NOTICE



**BEFORE OPERATING THIS MACHINE,
PLEASE READ THESE INSTRUCTIONS CAREFULLY**

ATTENTION !

1. Check every faster and make sure that the sprayer and the engine are installed firmly on the frame.
2. Set the two pulleys in a straight line and the belt in an appropriate tightness.
3. Check whether there is sufficient engine oil and use right fuel.
4. Before starting the engine, check both the on/off switches of engine and carburetor.
5. Affix the suction hose to the inlet of the sprayer. Leave the filter of suction hose 20cm far from the bottom of the water tank in order to prolong the life of the sprayer.
6. Make sure that the water supply is sufficient enough to help the pump reach its working pressure.
7. Affix spray hose and spray gun.
8. Open the exhaust cock then before starting the engine in order to release the air in the pump. Before using spray gun or spraying, assure the circulation of water in the pump functions properly.
9. To prolong the life of the pump, do operate the machine according to its specific pressure. Adjust the pressure clockwise switching the adjustable valve.
10. In order to avoid any damage of packing and the pump, shut off the engine when temporarily stop operating the unit for more than 5 minutes.
11. Renew oil in the pump after using for the first 10-15hours. Renew oil in the pump after the use of pump for every 70hours. Please make sure the oil is in usable condition before operating.
12. Drain the sludge before renew new oil.
13. Screw the nut before refilling the #30-#40 oil then refill the oil up to the level of 213 of the oil window.
14. Always fill the grease cup with grease. Twist the grease cup twice every 2 spraying hour.
15. After finishing spraying, loose the pressure regulator handle and operate the sprayer with fresh water to clean out the remaining chemicals.
16. Do not direct the jet of water aiming at people.
17. Operation carefully, the engine working temperature is very hot.
18. Do not touch the pulleys and belts when sprayer running at high revolution.

AGRIMATE Maximum Power - Super Economy

TRUBLE SHOOTING

1. Installity of working pressure and water supply:
 - A. Check whether the suction hose leaks or sticks.
 - B. Open the ball cock to release the surplus air.
 - C. Remove the water inlet cover to check if the valve asst' are stuck or damaged.

TECHNICAL SPECIFICATION

AM 30 AUTO SPRAYER

Plunger diaxstroke	3 x 30 x 20 mm
Plunger Length	140 mm
Spraying Pressure	20 - 40 kg/cm ²
Suction Volume	21-42 L / Min
Speed	500-1200 rpm
Mating Power	4-5.5 HP
Net weight	12 Kg
Dimension	42 x 31 x 35 cm

SPARE PART LIST OF AM 30 AUTO HTP POWER SPRAYER

Part No.	Description	Q'ty
AM 30 A-01	Crankcase	1
AM 30 A-02	just-proof cap	1
AM 30 A-03	pulley	1
AM 30 A-04	set bolt	1
AM 30 A-05	set bolt	6
AM 30 A-06	crankshaft oil seal cove	1
AM 30 A-07	oil inlet cover assembly	1
AM 30 A-08	rear cover packing	1
AM 30 A-09	rear cover	1
AM 30 A-10	set bolt	4
AM 30 A-11	oil window assembly	1
AM 30 A-12	drainage screw	1
AM 30 A-13	crankshaft key	1
AM 30 A-14	crankshaft	1
AM 30 A-15	connecting rod assembly	3
AM 30 A-16	bearing	2
AM 30 A-17	crankshaft oil seal	2
AM 30 A-18	crankshaft oil seal cove	1
AM 30 A-19	piston assembly	3
AM 30 A-20	piston rod	3

SPARE PART LIST OF AM 30 AUTO HTP POWER SPRAYER

Part No.	Description	Q'ty
AM 30 A-21	ceramic piston sleeve	3
AM 30 A-22	double-end screw	3
AM 30 A-23	o-ring	3
AM 30 A-24	gasket	3
AM 30 A-25	set bolt	3
AM 30 A-26	piston pin	3
AM 30 A-27	piston[s.s]	3
AM 30 A-28	Crankcase stand	2
AM 30 A-29	screw, washer	4
AM 30 A-30	set pin	2
AM 30 A-31	piston oil seal	3
AM 30 A-32	waterproof ring	3
AM 30 A-40	cylinder cast iron	1
AM 30 A-41	screw, washer	4
AM 30 A-42	double-end screw	2
AM 30 A-43	nut, gasket	2
AM 30 A-44	grease cup brass	3
AM 30 A-45	v-packing seat	3
AM 30 A-46	v-packing	9
AM 30 A-47	grease ring	3

SPARE PART LIST OF AM 30 AUTO HTP POWER SPRAYER

Part No.	Description	Q'ty
AM 30 A-48	v-type o-ring	3
AM 30 A-49	adjusting ring	3
AM 30 A-50	set clip	3
AM 30 A-51	suction chamber	1
AM 30 A-52	suction chamber cap	1
AM 30 A-53	screw, washer	2
AM 30 A-54	valve assembly	6
AM 30 A-55	valve cap	6
AM 30 A-56	Valve spring	6
AM 30 A-57	valve plug	6
AM 30 A-58	valve seat	6
AM 30 A-59	valve packing	6
AM 30 A-70	screw kit	1
AM 30 A-71	adjusting-ring spanner	1
AM 30 A-72	cross-screw drive	1
AM 30 A-73	open chamber	1
AM 30 A-80	outlet chamber	1
AM 30 A-81	O-ring	1
AM 30 A-82	pressure gauge	1
AM 30 A-83	t-type ball valve	1

SPARE PART LIST OF AM 30 AUTO HTP POWER SPRAYER

Part No.	Description	Q'ty
AM 30 A-111	unloading valve cylinde	1
AM 30 A-112	ball cock	1
AM 30 A-113	screw,washer	2
AM 30 A-114	o-ring(F.P.M)	2
AM 30 A-115	auxiliary spring	1
AM 30 A-116	piston valve assembly	1
AM 30 A-117	piston valve body	1
AM 30 A-118	screw	1
AM 30 A-119	valve plug head	1
AM 30 A-120	o-ring(F.P.M)	1
AM 30 A-121	valve plug set	1
AM 30 A-122	spring	1
AM 30 A-123	spring set	1
AM 30 A-124	c-type ring	1
AM 30 A-125	gasket	1
AM 30 A-126	Auxiliary plate	1
AM 30 A-127	valve set	1
AM 30 A-128	pressure valve	1
AM 30 A-129	damper plate	1
AM 30 A-130	valve rod	1

SPARE PART LIST OF AM 30 AUTO HTP POWER SPRAYER

Part No.	Description	Q'ty
AM 30 A-131	overflow chamber	1
AM 30 A-132	screw,washer	4
AM 30 A-133	compression packing	1
AM 30 A-134	washer	1
AM 30 A-135	set ring	1
AM 30 A-136	spring seat	1
AM 30 A-137	pressure regulating spring	1
AM 30 A-138	spring seat	1
AM 30 A-139	pressure regulating pipe	1
AM 30 A-140	pressure regulating screw	1
AM 30 A-141	overflow hose coupling	1
AM 30 A-180	filter	1
AM 30 A-181	socket	1
AM 30 A-182	suction hose	1
AM 30 A-183	suction hose wing nut	1
AM 30 A-184	suction hose socket general	1
AM 30 A-185	overflow hose	1
AM 30 A-186	overflow hose wing nut	1
AM 30 A-187	overflow hose socket general	1

INSPECTION & MAINTENANCE

For safety use, make sure the machine is cleaned every three-months. Before working, make sure to inspect the filter and the nozzle, and ensure there is no impurity. After working, make sure there is no water in the pump and the hose.

If the machine needs to be repaired in the guarantee period, please return the machine to the shop. You need to provide the certificate of purchase in order to repair or get the substitute.

Before Packing, the machine should be cleaned, then use closed packaging, packaging should be firm. Store the machine in dry place.

For transportation safety. The machine should comply with ISTA.



Meaning of crossed - out wheeled dustbin:

Do not dispose of electrical machines as unsorted municipal waste, use separate collection facilities.

If electrical machines are disposed of in landfills or dumps, hazardous substances can leak into the groundwater and get into the food chain, damaging your health and well-being.

When replacing old machines with new ones, the retailer is legally obligated to take back your old machine for disposals at least free of charge.

Warranty Card

CUSTOMER COPY



Purchaser's Name & Address

Product Name

AM 30 AUTO HTP POWER SPRAYER

Product Serial No.

Invoice / DN No.

Date of Delivery

Dealer's Office Seal

Dealer Sign _____

Customer Sign. _____

I/We accept the terms and conditions of Warranty as in the Warranty Card.

Warranty Card

DEALER'S COPY



Purchaser's Name & Address

Product Name

AM 30 AUTO HTP POWER SPRAYER

Product Serial No.

Invoice / DN No.

Date of Delivery

Dealer's Office Seal

Dealer Sign _____

Customer Sign. _____

I/We accept the terms and conditions of Warranty as in the Warranty Card.

Warranty Card

COMPANY COPY



Purchaser's Name & Address

Product Name

AM 30 AUTO HTP POWER SPRAYER

Product Serial No.

Invoice / DN No.

Date of Delivery

Dealer's Office Seal

Dealer Sign _____

Customer Sign. _____

I/We accept the terms and conditions of Warranty as in the Warranty Card.

1. **LIMITED WARRANTY PERIOD** : For a period of six months from the date of Sale / delivery of the product which ever is earlier. 2. **LIMITED WARRANTY OBLIGATION** : Replacement of defective part(s) by authorized dealer are free of charges. If found defective by reasons of defective material / poor workmanship, parts will be replaced and there will be no value re-imbursalment. 3. **TERMS & CONDITIONS** : a. Claims under warranty will be accepted on submission of Warranty Card duly filled and stamped by authorized dealer together with the original purchase document . b. Shipping / transportation / Incidental charges incurred in replacing defective parts under warranty shall be borne by the purchaser.

WARRANTY null & void if

- (i) Lack of maintenance, (ii) Incorrect use of the machine or tampering, (iii) Use of non-genuine spare parts, (iv) Usage of acids, solvents, or any flammable materials, (v) Non-usage of filter water / clear water / soft water & using water above 40°C temperature, (vi) While using the pressure washers to draw water which is contaminated with dust & solvents (eg. paint thinners, gasoline, oil, etc.), (vii) Repair done by unauthorized service people, (viii) Those parts subject to wear & tear due to normal operations and plastic parts, rubber items etc, (ix) Loose connections, faulty electrical fixtures & fluctuations in power supply.
4. Should any failure occur during or after the warranty period, customer does not have the right to interrupt payment / price discount.
5. Incidental or consequential damages like inconvenience commercial loss, loss of tie, mental agony etc.
6. Loss of any nature due to operation or non-operation is not covered under warranty.
7. All free service are at Dealer's service point only.
8. Warranty ceases if service is not done periodically.
9. The attached card should be completed and returned to Ratnagiri Impex Pvt. Ltd. for registration immediately after sale / delivery.
10. The warranty is void unless you register the warranty card with Ratnagiri Impex Pvt. Ltd.
11. The decision of Ratnagiri Impex Pvt. Ltd., in settling the warranty is final in all respects.
12. All disputes are subject to Bangalore Courts Jurisdiction

1. **LIMITED WARRANTY PERIOD** : For a period of six months from the date of Sale / delivery of the product which ever is earlier. 2. **LIMITED WARRANTY OBLIGATION** : Replacement of defective part(s) by authorized dealer are free of charges. If found defective by reasons of defective material / poor workmanship, parts will be replaced and there will be no value re-imbursalment. 3. **TERMS & CONDITIONS** : a. Claims under warranty will be accepted on submission of Warranty Card duly filled and stamped by authorized dealer together with the original purchase document . b. Shipping / transportation / Incidental charges incurred in replacing defective parts under warranty shall be borne by the purchaser.

WARRANTY null & void if

- (i) Lack of maintenance, (ii) Incorrect use of the machine or tampering, (iii) Use of non-genuine spare parts, (iv) Usage of acids, solvents, or any flammable materials, (v) Non-usage of filter water / clear water / soft water & using water above 40°C temperature, (vi) While using the pressure washers to draw water which is contaminated with dust & solvents (eg. paint thinners, gasoline, oil, etc.), (vii) Repair done by unauthorized service people, (viii) Those parts subject to wear & tear due to normal operations and plastic parts, rubber items etc, (ix) Loose connections, faulty electrical fixtures & fluctuations in power supply.
4. Should any failure occur during or after the warranty period, customer does not have the right to interrupt payment / price discount.
5. Incidental or consequential damages like inconvenience commercial loss, loss of tie, mental agony etc.
6. Loss of any nature due to operation or non-operation is not covered under warranty.
7. All free service are at Dealer's service point only.
8. Warranty ceases if service is not done periodically.
9. The attached card should be completed and returned to Ratnagiri Impex Pvt. Ltd. for registration immediately after sale / delivery.
10. The warranty is void unless you register the warranty card with Ratnagiri Impex Pvt. Ltd.
11. The decision of Ratnagiri Impex Pvt. Ltd., in settling the warranty is final in all respects.
12. All disputes are subject to Bangalore Courts Jurisdiction

1. **LIMITED WARRANTY PERIOD** : For a period of six months from the date of Sale / delivery of the product which ever is earlier. 2. **LIMITED WARRANTY OBLIGATION** : Replacement of defective part(s) by authorized dealer are free of charges. If found defective by reasons of defective material / poor workmanship, parts will be replaced and there will be no value re-imbursalment. 3. **TERMS & CONDITIONS** : a. Claims under warranty will be accepted on submission of Warranty Card duly filled and stamped by authorized dealer together with the original purchase document . b. Shipping / transportation / Incidental charges incurred in replacing defective parts under warranty shall be borne by the purchaser.

WARRANTY null & void if

- (i) Lack of maintenance, (ii) Incorrect use of the machine or tampering, (iii) Use of non-genuine spare parts, (iv) Usage of acids, solvents, or any flammable materials, (v) Non-usage of filter water / clear water / soft water & using water above 40°C temperature, (vi) While using the pressure washers to draw water which is contaminated with dust & solvents (eg. paint thinners, gasoline, oil, etc.), (vii) Repair done by unauthorized service people, (viii) Those parts subject to wear & tear due to normal operations and plastic parts, rubber items etc, (ix) Loose connections, faulty electrical fixtures & fluctuations in power supply.
4. Should any failure occur during or after the warranty period, customer does not have the right to interrupt payment / price discount.
5. Incidental or consequential damages like inconvenience commercial loss, loss of tie, mental agony etc.
6. Loss of any nature due to operation or non-operation is not covered under warranty.
7. All free service are at Dealer's service point only.
8. Warranty ceases if service is not done periodically.
9. The attached card should be completed and returned to Ratnagiri Impex Pvt. Ltd. for registration immediately after sale / delivery.
10. The warranty is void unless you register the warranty card with Ratnagiri Impex Pvt. Ltd.
11. The decision of Ratnagiri Impex Pvt. Ltd., in settling the warranty is final in all respects.
12. All disputes are subject to Bangalore Courts Jurisdiction



ratnagiri impex
BRINGING THE BEST TO THE FUTURE - NOW

1st Free Service Coupon

ISO 9001-2015
CERTIFIED COMPANY

FREE SERVICE COUPON (30 Days / 20 hrs (Which ever is earlier))

Model
AM 30 AUTO HTP POWER SPRAYER

PDI Date

Service No.

Purchase bill no. _____ Date _____

Dealer's Office Seal & Signature

Serial Number

Customer Signature.....

Conditions: Operations listed have been performed to my entire satisfaction without any labour charges. Only consumables were charged.



agriculture | horticulture | sericulture | plantations | forestry | garden | health care

WARRANTY AND FREE SERVICE COUPON



ratnagiri impex
BRINGING THE BEST TO THE FUTURE - NOW

2nd Free Service Coupon

ISO 9001-2015
CERTIFIED COMPANY

FREE SERVICE COUPON (30 Days / 20 hrs (Which ever is earlier))

Model
AM 30 AUTO HTP POWER SPRAYER

PDI Date

Service No.

Purchase bill no. _____ Date _____

Dealer's Office Seal & Signature

Serial Number

Customer Signature.....

Conditions: Operations listed have been performed to my entire satisfaction without any labour charges. Only consumables were charged.



agriculture | horticulture | sericulture | plantations | forestry | garden | health care

WARRANTY AND FREE SERVICE COUPON



ratnagiri impex
BRINGING THE BEST TO THE FUTURE - NOW

3rd Free Service Coupon

ISO 9001-2015
CERTIFIED COMPANY

FREE SERVICE COUPON (30 Days / 20 hrs (Which ever is earlier))

Model
AM 30 AUTO HTP POWER SPRAYER

PDI Date

Service No.

Purchase bill no. _____ Date _____

Dealer's Office Seal & Signature

Serial Number

Customer Signature.....

Conditions: Operations listed have been performed to my entire satisfaction without any labour charges. Only consumables were charged.



agriculture | horticulture | sericulture | plantations | forestry | garden | health care

WARRANTY AND FREE SERVICE COUPON



Small Maintenance. Big Savings.



Small Maintenance. Big Savings.



Small Maintenance. Big Savings.

Do's & Don'ts

- Always read the instruction manual supplied along with the equipments and understand the correct installation and operating procedures before attempting to use the equipments.
- It is important to use the personal protection equipments such as head helmet with visor, ear defenders, goggles, safety gloves, cut resistant shoes, trousers and jackets while operating potentially dangerous machines.
- Avoid untrained persons using the equipments. Children must not be allowed to handle these equipments.
- Always use genuine spares and accessories in repairs and usage to derive maximum life of the equipments.
- Always keep the equipments in good working condition to minimise loss of output as well as to reduce the pollution and save the environment.
- Do not use the machine within range of persons unless they wear protective clothing.
- Do not operate the machine when fatigued or under the influence of alcohol or drugs.
- When the machine is running, please maintain a constant water supply. Without water circulation will damage the sealing rings of the machine.
- For more query kindly contact for our Service Center/Dealer/ franchise

Agrimate Army For Pest Control

ANY WHERE - ANY TIME - ANY CROP

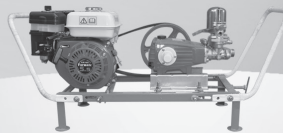

AGRIMATE[®]
Maximum Power - Super Economy

RATNAGIRI IMPEX PVT., LTD.,
Annapurna House, #1/1G, 7th Cross, New Guddadahalli
Mysore Road, Bangalore - 560 026
Customer Care: 1800-425-3036
Email: info@ratnagiriimpex.com



 **ratnagiri**[®]
impex
BRINGING YOU THE FUTURE... NOW

www.ratnagiriimpex.com

AN ISO 9001:2015 CERTIFIED COMPANY