

AGRIMATE BRUSH CUTTER

AM-400-BC-4S-PRO

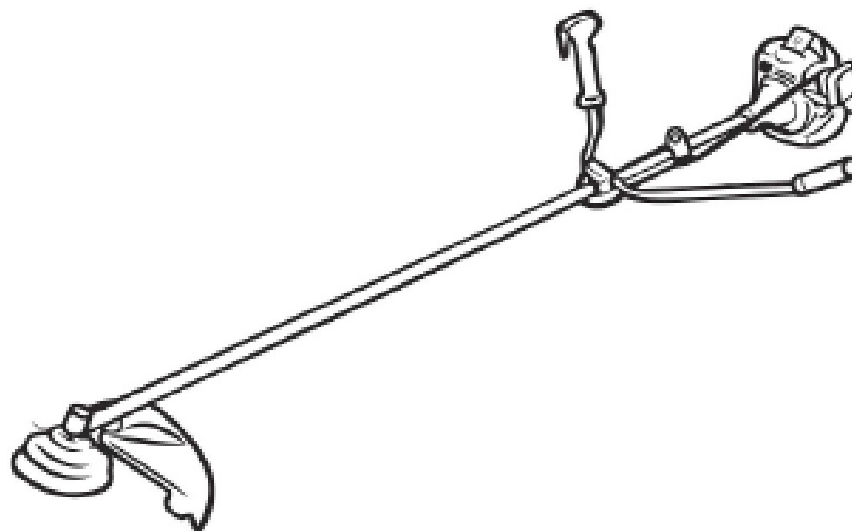

TECHNICAL SPECIFICATIONS

Product	BRUSH CUTTER
Model	AM-400-BC-4S-PRO
Engine Type	4 stroke
Displacement	35.8cc
Engine Power	6500rpm/0.9kw
Caburetor	Diaphragm-type
Fuel tank capacity	0.65L

TRANSMISSION DIAGRAM & SPARE PART LIST OF AM-400-BC-4S

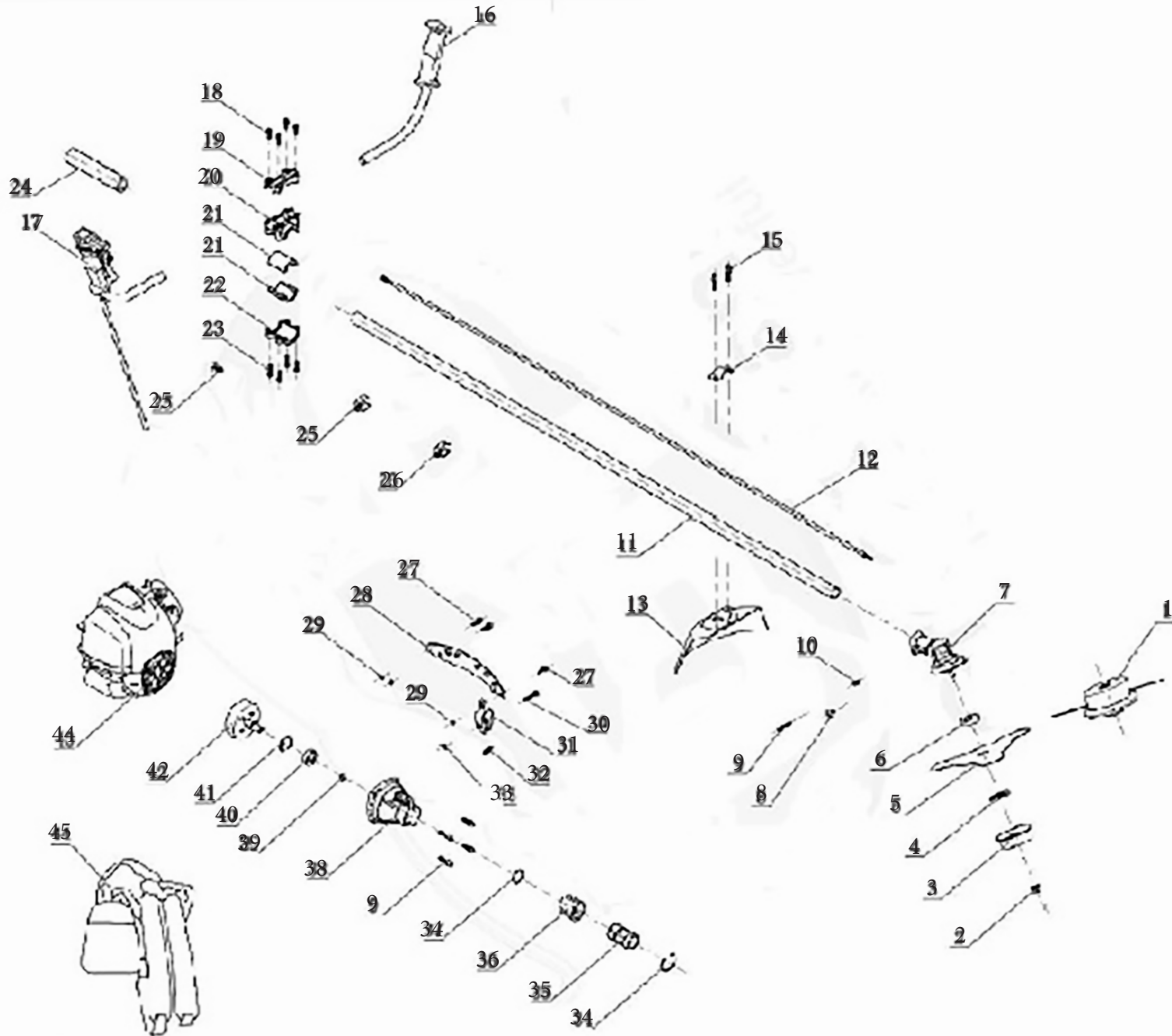

TRANSMISSION DIAGRAM & SPARE PART LIST OF AM-400-BC-4S

SL NO	PART NO	DESCRIPTION	SL NO	PART NO	DESCRIPTION
1	AM-400-T01	Trimmer head	17	AM-400-T17	Right switch handle
2	AM-400-T02	Lock nut	18	AM-400-T18	Comboined bolt
3	AM-400-T03	Blade sheild	19	AM-400-T19	Upper handle base
4	AM-400-T04	Press plate	20	AM-400-T20	Middle handle base
5	AM-400-T05	3T plate	21	AM-400-T21	Vibration reduce rubber
6	AM-400-T06	lock plate	22	AM-400-T22	Down handle base
7	AM-400-T07	Gear box	23	AM-400-T23	Comboined bolt
8	AM-400-T08	Round head bolt	24	AM-400-T24	Sponge sleeve
9	AM-400-T09	Comboined bolt	25	AM-400-T25	Cable locker
10	AM-400-T10	Comboined bolt	26	AM-400-T26	Cable locker
11	AM-400-T11	Shaft	27	AM-400-T27	Comboined bolt
12	AM-400-T12	Nine teeth shaft	28	AM-400-T28	Belt holder
13	AM-400-T13	Grass guard	29	AM-400-T29	Nut
14	AM-400-T14	Press plate	30	AM-400-T30	Comboined bolt
15	AM-400-T15	Comboined bolt	31	AM-400-T31	Belt holder
16	AM-500-T16	Left switch handle	32	AM-400-T32	Lock sleeve

TRANSMISSION DIAGRAM & SPARE PART LIST OF AM-400-BC-4S

SL NO	PART NO	DESCRIPTION	SL NO	PART NO	DESCRIPTION
33	AM-400-T33	Spring			
34	AM-400-T34	Wing nut			
35	AM-400-T35	Baed flange			
36	AM-400-T36	Connector sleeve			
37	AM-400-T37	Rubber sleeve			
38	AM-400-T38	Shaft flage			
39	AM-400-T39	clutch housing			
40	AM-400-T40	Shaft flage			
41	AM-400-T41	Roliing bearing			
42	AM-400-T42	Bead falnge			
43	AM-400-T43	Drum			
44	AM-400-T44	Engine			
45	AM-400-T45	Bolt			

ENGINE DIAGRAM & SPARE PART LIST OF AM-400-BC-4S /AM-435-4S-BC BRUSH CUTTER

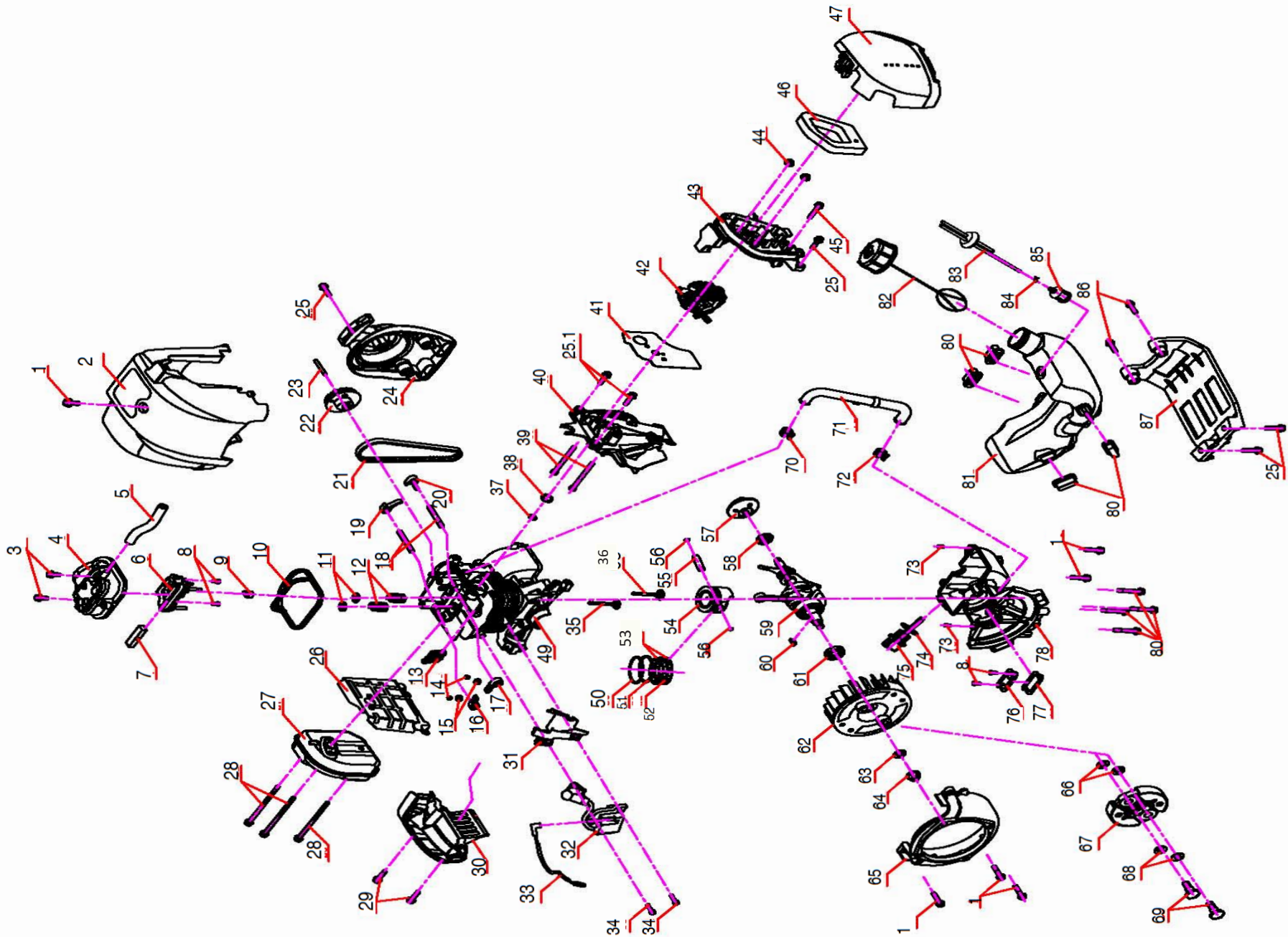

ENGINE DIAGRAM & SPARE PART LIST OF AM-400-BC-4S

SL NO	PART NO	DESCRIPTION	SL NO	PART NO	DESCRIPTION
1	AM-AX35-E01	Hex flange surface screw	17	AM-AX35-E17	Intake rocker arm
2	AM-AX35-E02	Engine plastic cover	18	AM-AX35-E18	Roker pin
3	AM-AX35-E03	Self-tapping screw	19	AM-AX35-E19	Exhaust valve rocker
4	AM-AX35-E04	Cylinder cover	20	AM-AX35-E20	Intake valve rocker
5	AM-AX35-E05	Wind pipe	21	AM-AX35-E21	Synchronous belt
6	AM-AX35-E06	Inside cover	22	AM-AX35-E22	Cam wheel
7	AM-AX35-E07	Oil gas separator	23	AM-AX35-E23	Camshaft
8	AM-AX35-E08	Screw	24	AM-AX35-E24	Starter
9	AM-AX35-E09	Oil sucker cover	25	AM-AX35-E25	Screw
10	AM-AX35-E10	Cylinder cover seal	26	AM-AX35-E26	Muffler baffle
11	AM-AX35-E11	Valve locker	27	AM-AX35-E27	Muffler
12	AM-AX35-E12	Valve spring	28	AM-AX35-E28	Screw
13	AM-AX35-E13	Spark plug	29	AM-AX35-E29	Screw
14	AM-AX35-E14	Valve adjusting screw	30	AM-AX35-E30	Muffler baffle-2
15	AM-AX35-E15	Valve adjusting nut	31	AM-AX35-E31	Baffle
16	AM-AX35-E16	Exhaust rocker arm	32	AM-AX35-E32	Ignition stator

ENGINE DIAGRAM & SPARE PART LIST OF AM-400-BC-4S





SL NO	PART NO	DESCRIPTION	SL NO	PART NO	DESCRIPTION
33	AM-AX35-E33	Stopping wire	49	AM-AX35-E49	Cylinder
34	AM-AX35-E34	Screw	50	AM-AX35-E50	NO.1 piston ring
35	AM-AX35-E35	Exhaust valve	51	AM-AX35-E51	NO.2 piston ring
36	AM-AX35-E36	Intake valve	52	AM-AX35-E52	Liner ring
37	AM-AX35-E37	Admitting gasket	53	AM-AX35-E53	Oil scraper ring
38	AM-AX35-E38	O-seal ring	54	AM-AX35-E54	Piston
39	AM-AX35-E39	Screw	55	AM-AX35-E55	Piston pin
40	AM-AX35-E40	Admitting pipe	56	AM-AX35-E56	Ring
25.1	AM-AX35-E25.1	Screw	57	AM-AX35-E57	Start reel
41	AM-AX35-E41	Carburetor gasket	58	AM-AX35-E58	Oil seal
42	AM-AX35-E42	Carburetor	59	AM-AX35-E59	Crankshaft
43	AM-AX35-E43	Cleaner inside cover	60	AM-AX35-E60	Key
44	AM-AX35-E44	Nut	61	AM-AX35-E61	Oil seal
45	AM-AX35-E45	Screw	62	AM-AX35-E62	Magneto rotor comp.
46	AM-AX35-E46	Filter	63	AM-AX35-E63	Washer
47	AM-AX35-E47	Air filter cover	64	AM-AX35-E64	Nut
48	AM-AX35-E48	NA			

ENGINE DIAGRAM & SPARE PART LIST OF AM-400-BC-4S

SL NO	PART NO	DESCRIPTION	SL NO	PART NO	DESCRIPTION
65	AM-AX35-E65	Magneto cover	81	AM-AX35-E81	Fuel tank
66	AM-AX35-E66	Washer	82	AM-AX35-E82	Fuel tank lid
67	AM-AX35-E67	Clutch	83	AM-AX35-E83	Fuel pipe
68	AM-AX35-E68	Washer	84	AM-AX35-E84	Clamp
69	AM-AX35-E69	Screw pin	85	AM-AX35-E85	Filter
70	AM-AX35-E70	Holding-down clip	86	AM-AX35-E86	Screw
71	AM-AX35-E71	Balancing pressure pipe	87	AM-AX35-E87	Fuel tank cover
72	AM-AX35-E72	Holding-down clip			
73	AM-AX35-E73	Pin			
74	AM-AX35-E74	O-seal ring			
75	AM-AX35-E75	Oil scale			
76	AM-AX35-E76	Reed vavle			
77	AM-AX35-E77	Reed vavle gasket			
78	AM-AX35-E78	Crankcase			
79	AM-AX35-E79	Screw			
80	AM-AX35-E80	Rubber cushion			





WARRANTY CARD

CUSTOMER COPY

DATE _____	DATE OF DELIVERY _____	DEALERS OFFICIAL SEAL	DEALERS SIGN _____
PURCHASERS NAME & ADDRESS _____ _____	 CUSTOMER SIGN		
PRODUCT NAME	PRODUCT SERIAL NO.	INVOICE/DN NO.	
			

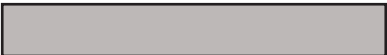



I/Will accept the terms and conditions of warranty as in the warranty card

DEALERS COPY

DATE _____	DATE OF DELIVERY _____	DEALERS OFFICIAL SEAL	DEALERS SIGN _____
PURCHASERS NAME & ADDRESS _____ _____	 CUSTOMER SIGN		
PRODUCT NAME	PRODUCT SERIAL NO.	INVOICE/DN NO.	
			

I/Will accept the terms and conditions of warranty as in the warranty card

COMPANY COPY

DATE _____	DATE OF DELIVERY _____	DEALERS OFFICIAL SEAL	DEALERS SIGN _____
PURCHASERS NAME & ADDRESS _____ _____	 CUSTOMER SIGN		
PRODUCT NAME	PRODUCT SERIAL NO.	INVOICE/DN NO.	
			

I/Will accept the terms and conditions of warranty as in the warranty card

1. LIMITED WARRANTY PERIOD : For a period of six months from the date of Sale / delivery of the product which ever is earlier. 2. LIMITED WARRANTY OBLIGATION : Replacement of defective part(s) by authorized dealer are free of charges. If found defective by reasons of defective material / poor workmanship, parts will be replaced and there will be no value re-imbusement. 3. TERMS & CONDITIONS : a. Claims under warranty will be accepted on submission of Warranty Card duly filled and stamped by authorized dealer together with the original purchase document. : b. Shipping / transportation / Incidental charges incurred in replacing defective parts under warranty shall be borne by the purchaser

WARRANTY null & void if

- (i) Lack of maintenance, (ii) Incorrect use of the machine or tampering, (iii) Use of non-genuine spare parts, (iv) Usage of acids, solvents, or any flammable materials, (v) Non-usage of filter water / clear water / soft water & using water above 40°C temperature, (vi) While using the pressure washers to draw water which is contaminated with dust & solvents (eg. paint thinners, gasoline, oil, etc.), (vii) Repair done by unauthorized service people, (viii) Those parts subject to wear & tear due to normal operations and plastic parts, rubber items etc, (ix) Loose connections, faulty electrical fixtures & fluctuations in power supply.
- 4. Should any failure occur during or after the warranty period, customer does not have the right to interrupt payment / price discount.
- 5. Incidental or consequential damages like inconvenience commercial loss, loss of tie, mental agony etc.
- 6. Loss of any nature due to operation or non-operation is not covered under warranty.
- 7. All free service are at Dealer's service point only.
- 8. Warranty ceases if service is not done periodically.
- 9. The attached card should be completed and returned to Ratnagiri Impex Pvt. Ltd. for registration immediately after sale / delivery.
- 10. The warranty is void unless you register the warranty card with Ratnagiri Impex Pvt. Ltd.
- 11. The decision of Ratnagiri Impex Pvt. Ltd., in settling the warranty is final in all respects.
- 12. All disputes are subject to Bangalore Courts Jurisdiction

1. LIMITED WARRANTY PERIOD : For a period of six months from the date of Sale / delivery of the product which ever is earlier. 2. LIMITED WARRANTY OBLIGATION : Replacement of defective part(s) by authorized dealer are free of charges. If found defective by reasons of defective material / poor workmanship, parts will be replaced and there will be no value re-imbusement. 3. TERMS & CONDITIONS : a. Claims under warranty will be accepted on submission of Warranty Card duly filled and stamped by authorized dealer together with the original purchase document. : b. Shipping / transportation / Incidental charges incurred in replacing defective parts under warranty shall be borne by the purchaser.

WARRANTY null & void if

- (i) Lack of maintenance, (ii) Incorrect use of the machine or tampering, (iii) Use of non-genuine spare parts, (iv) Usage of acids, solvents, or any flammable materials, (v) Non-usage of filter water / clear water / soft water & using water above 40°C temperature, (vi) While using the pressure washers to draw water which is contaminated with dust & solvents (eg. paint thinners, gasoline, oil, etc.), (vii) Repair done by unauthorized service people, (viii) Those parts subject to wear & tear due to normal operations and plastic parts, rubber items etc, (ix) Loose connections, faulty electrical fixtures & fluctuations in power supply.
- 4. Should any failure occur during or after the warranty period, customer does not have the right to interrupt payment / price discount.
- 5. Incidental or consequential damages like inconvenience commercial loss, loss of tie, mental agony etc.
- 6. Loss of any nature due to operation or non-operation is not covered under warranty.
- 7. All free service are at Dealer's service point only.
- 8. Warranty ceases if service is not done periodically.
- 9. The attached card should be completed and returned to Ratnagiri Impex Pvt. Ltd. for registration immediately after sale / delivery.
- 10. The warranty is void unless you register the warranty card with Ratnagiri Impex Pvt. Ltd.
- 11. The decision of Ratnagiri Impex Pvt. Ltd., in settling the warranty is final in all respects.
- 12. All disputes are subject to Bangalore Courts Jurisdiction

1. LIMITED WARRANTY PERIOD : For a period of six months from the date of Sale / delivery of the product which ever is earlier. 2. LIMITED WARRANTY OBLIGATION : Replacement of defective part(s) by authorized dealer are free of charges. If found defective by reasons of defective material / poor workmanship, parts will be replaced and there will be no value re-imbusement. 3. TERMS & CONDITIONS : a. Claims under warranty will be accepted on submission of Warranty Card duly filled and stamped by authorized dealer together with the original purchase document. : b. Shipping / transportation / Incidental charges incurred in replacing defective parts under warranty shall be borne by the purchaser.

WARRANTY null & void if

- (i) Lack of maintenance, (ii) Incorrect use of the machine or tampering, (iii) Use of non-genuine spare parts, (iv) Usage of acids, solvents, or any flammable materials, (v) Non-usage of filter water / clear water / soft water & using water above 40°C temperature, (vi) While using the pressure washers to draw water which is contaminated with dust & solvents (eg. paint thinners, gasoline, oil, etc.), (vii) Repair done by unauthorized service people, (viii) Those parts subject to wear & tear due to normal operations and plastic parts, rubber items etc, (ix) Loose connections, faulty electrical fixtures & fluctuations in power supply.
- 4. Should any failure occur during or after the warranty period, customer does not have the right to interrupt payment / price discount.
- 5. Incidental or consequential damages like inconvenience commercial loss, loss of tie, mental agony etc.
- 6. Loss of any nature due to operation or non-operation is not covered under warranty.
- 7. All free service are at Dealer's service point only.
- 8. Warranty ceases if service is not done periodically.
- 9. The attached card should be completed and returned to Ratnagiri Impex Pvt. Ltd. for registration immediately after sale / delivery.
- 10. The warranty is void unless you register the warranty card with Ratnagiri Impex Pvt. Ltd.
- 11. The decision of Ratnagiri Impex Pvt. Ltd., in settling the warranty is final in all respects.
- 12. All disputes are subject to Bangalore Courts Jurisdiction



FREE SERVICE COUPON (30DAYS/30HRS. WHICHEVER IS EARLIER)

MODEL

SERIAL NUMBER

PDI DATE

SERVICE NO.

PURCHASE BILL NO.

DATE

DEALERS OFFICE SEAL

- 1. Check and test the fuel mixture
- 3. Check , clean and adjust the spark plug
- 5. Check and sparken the cutting tools
- 7. Start and check the noise, vibration, loosen etc..

OPERATIONS

- 2. check and clean the air filter
- 4. Check and adjust the carburetor tuning
- 6. Product familirisation on usage
- 8. Routine maintenance and shortage.

FREE SERVICE COUPON (30DAYS/30HRS. WHICHEVER IS EARLIER)

MODEL

SERIAL NUMBER

PDI DATE

SERVICE NO.

PURCHASE BILL NO.

DATE

DEALERS OFFICE SEAL

- 1. Check and test the fuel mixture
- 3. Check , clean and adjust the spark plug
- 5. Check and sparken the cutting tools
- 7. Start and check the noise, vibration, loosen etc..

OPERATIONS

- 2. check and clean the air filter
- 4. Check and adjust the carburetor tuning
- 6. Product familirisation on usage
- 8. Routine maintenance and shortage.

FREE SERVICE COUPON (30DAYS/30HRS. WHICHEVER IS EARLIER)

MODEL

SERIAL NUMBER

PDI DATE

SERVICE NO.

PURCHASE BILL NO.

DATE

DEALERS OFFICE SEAL

- 1. Check and test the fuel mixture
- 3. Check , clean and adjust the spark plug
- 5. Check and sparken the cutting tools
- 7. Start and check the noise, vibration, loosen etc..

OPERATIONS

- 2. check and clean the air filter
- 4. Check and adjust the carburetor tuning
- 6. Product familirisation on usage
- 8. Routine maintenance and shortage.

DOS

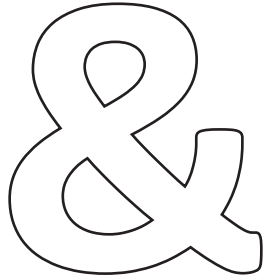

DONT'S

1. Always read the instruction manual supplied along with the equipments and understand the correct installation and operating procedures before attempting to use the equipments.
2. It is important to use the personal protection equipments such as head helmet with visor, ear defenders, goggles, safety gloves, cut resistant shoes, trousers and jackets while operating potentially dangerous machines
3. Avoid untrained persons using the equipments. Children must not be allowed to handle these equipments
4. Always use genuine spares and accessories in repairs and usage to derive maximum life of the equipments.
5. Always keep the equipments in good working condition to minimize loss of output as well as to reduce the pollution and save the environment
6. Do not use the machine within range of persons unless they wear protective clothing
7. Do not operate the machine when fatigued or under the influence of alcohol or drugs
8. When the machine is running, please maintain a constant water supply. Without water circulation will damage the sealing rings of the machine.
9. For more query kindly contact for our Service Center/Dealer/ franchise

Agrimate Army For Pest Control

ANY WHERE - ANY TIME - ANY CROP

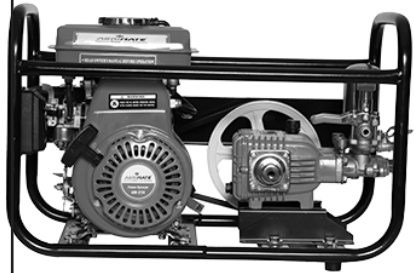
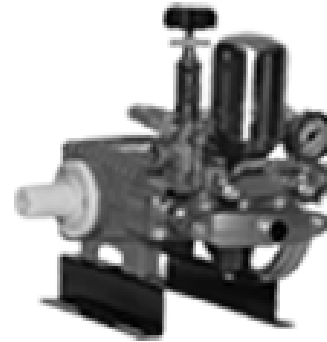

Marketed by:
**ratnagiri
impex**
BRINGING YOU THE FUTURE... NOW

RATNAGIRI IMPEX PVT., LTD.,

Annapurna House, #1 / 1G, 7th Cross, New
Guddadahalli

Mysore Road, Bangalore - 560 026

Missed Call : 7393 938 938

Email: ask@agrimart.in