

INTERCULTIVATOR / POWER WEEDER

AM-MPTC-1100-9D-E-WC



AM-MPTC-1100-9D-E-WC



MF HANDLE TYPE 1

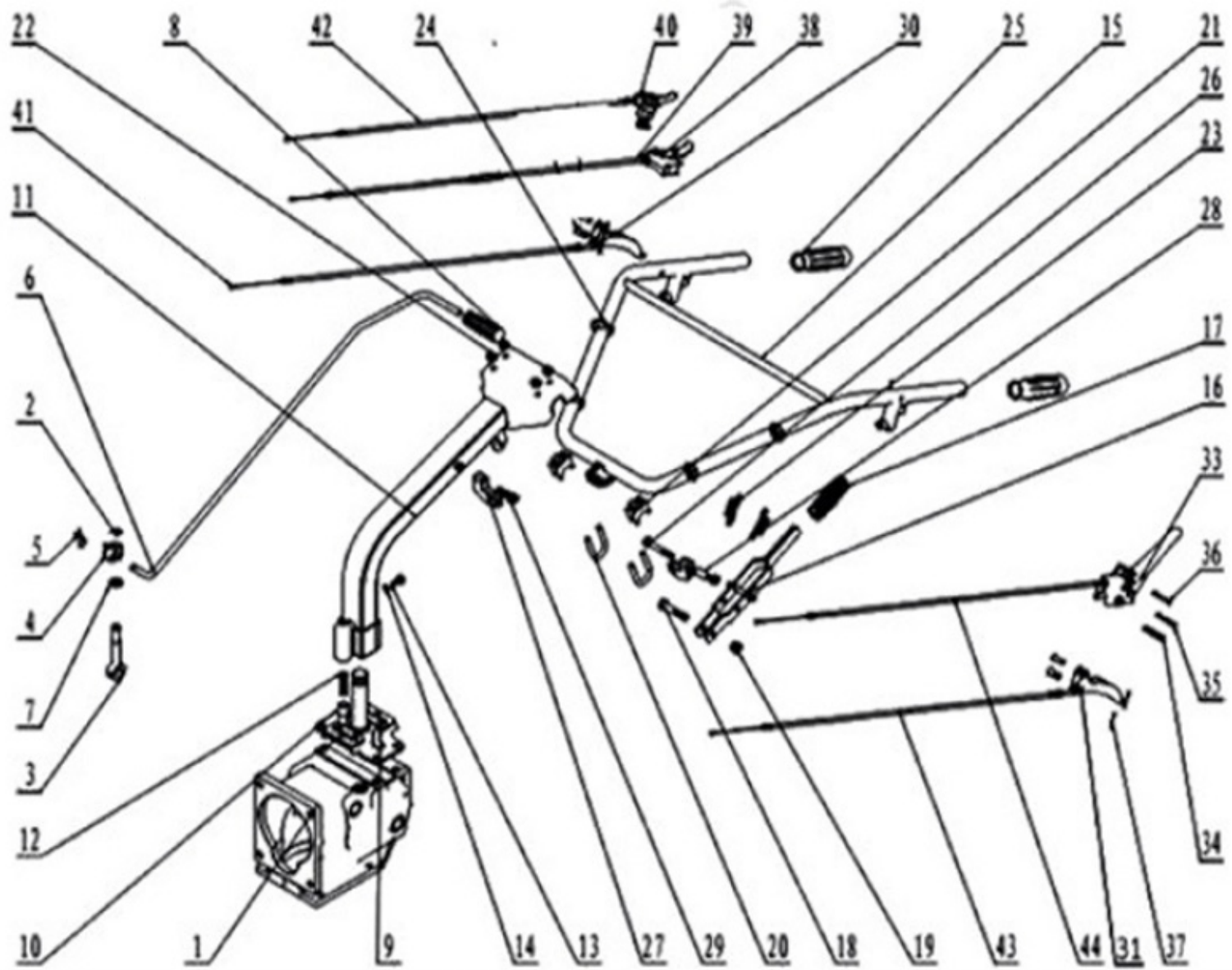

SL NO	PART NO	DESCRIPTION	SL NO	PART NO	DESCRIPTION
1	AM-MPT-1100-9D-TG-01	Shift Gear	17	AM-MPT-1100-9D-TG-17	Grips Height setting
2	AM-MPT-1100-9D-TG-02	Split ring 9	18	AM-MPT-1100-9D-TG-18	Bolt
3	AM-MPT-1100-9D-TG-03	Sheath , Shift Rod	19	AM-MPT-1100-9D-TG-19	Nut
4	AM-MPT-1100-9D-TG-04	PTO Higer B	20	AM-MPT-1100-9D-TG-20	U Bolt
5	AM-MPT-1100-9D-TG-05	Clip F	21	AM-MPT-1100-9D-TG-21	Handle seat Comp
6	AM-MPT-1100-9D-TG-06	Shift lever	22	AM-MPT-1100-9D-TG-22	Nut
7	AM-MPT-1100-9D-TG-07	Washer C Class	23	AM-MPT-1100-9D-TG-23	Spring
8	AM-MPT-1100-9D-TG-08	Handle bar	24	AM-MPT-1100-9D-TG-24	Clip
9	AM-MPT-1100-9D-TG-09	Handle Bar Seat assy	25	AM-MPT-1100-9D-TG-25	Grip
10	AM-MPT-1100-9D-TG-10	Pin	26	AM-MPT-1100-9D-TG-26	Bolt
11	AM-MPT-1100-9D-TG-11	Handle Bar seat assy	27	AM-MPT-1100-9D-TG-27	Locating piece
12	AM-MPT-1100-9D-TG-12	Spring	28	AM-MPT-1100-9D-TG-28	Washer, locating piece
13	AM-MPT-1100-9D-TG-13	Lock Comp Bolt	29	AM-MPT-1100-9D-TG-29	Bolt
14	AM-MPT-1100-9D-TG-14	Washer	30	AM-MPT-1100-9D-TG-30	Clutch Handle
15	AM-MPT-1100-9D-TG-15	Handle Bar assy	31	AM-MPT-1100-9D-TG-31	NA
16	AM-MPT-1100-9D-TG-16	Height setting	32	AM-MPT-1100-9D-TG-32	WM1050Switch Assy

SL NO	PART NO	DESCRIPTION	SL NO	PART NO	DESCRIPTION
34	AM-MPT-1100-9D-TG-34	Bolt			
35	AM-MPT-1100-9D-TG-35	Bolt			
36	AM-MPT-1100-9D-TG-36	NA			
37	AM-MPT-1100-9D-TG-37	Pin			
38	AM-MPT-1100-9D-TG-38	Turning Handle			
39	AM-MPT-1100-9D-TG-39	Turning cable			
40	AM-MPT-1100-9D-TG-40	Shut down Swicth Comp			
41	AM-MPT-1100-9D-TG-41	Reverse gear cable			
42	AM-MPT-1100-9D-TG-42	Throttle cable comp			
43	AM-MPT-1100-9D-TG-43	Clutch cable			
44	AM-MPT-1100-9D-TG-44	Flameout Switch cable c			

STANDARD HANDLE TYPE2

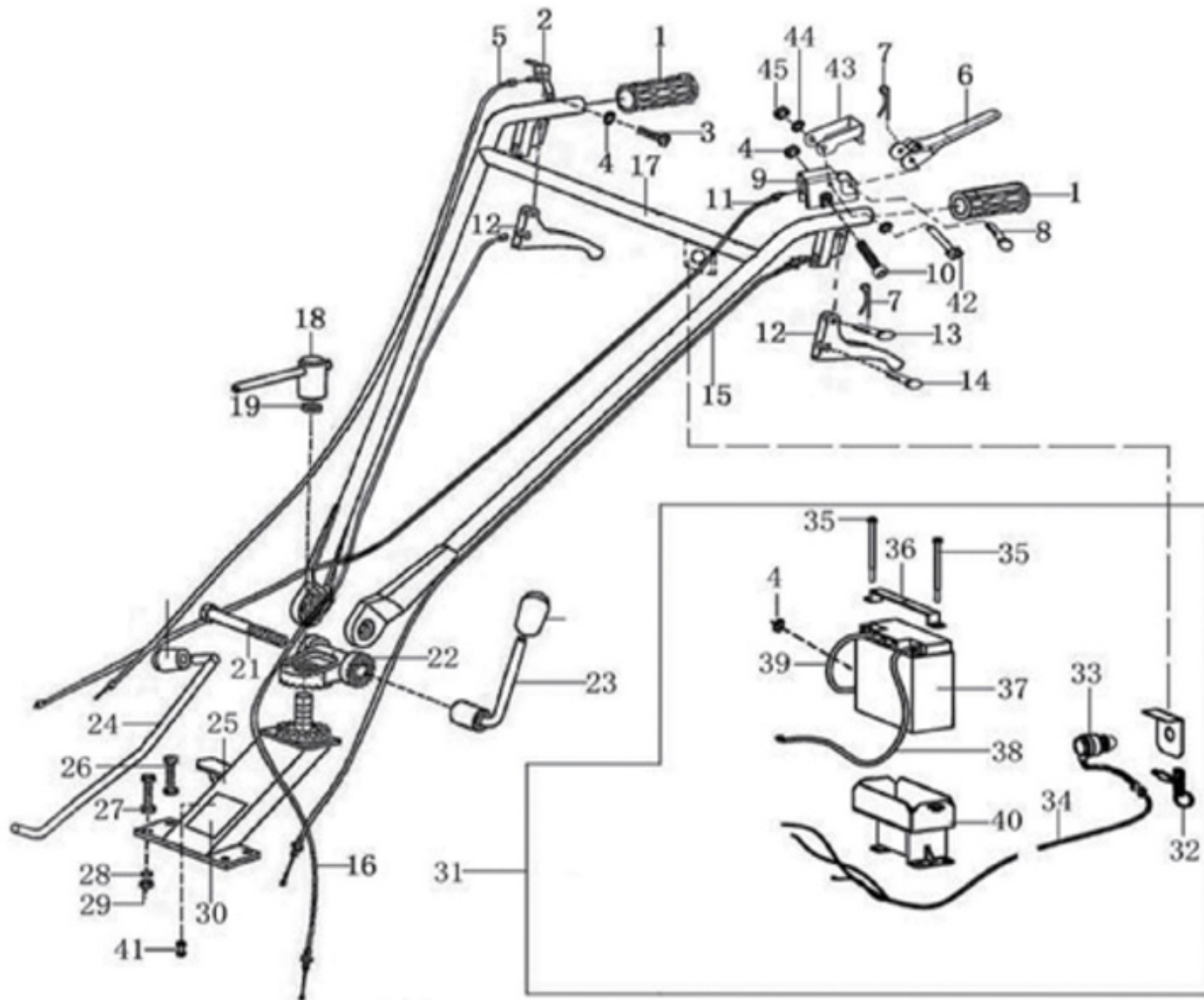

SL NO	PART NO	DESCRIPTION	SL NO	PART NO	DESCRIPTION
1	AM-MPT-1100-9D-A01	Handle Grip	17	AM-MPT-1100-9D-A17	Handle bar Assy
2	AM-MPT-1100-9D-A02	Shut Down Switch Comp	18	AM-MPT-1100-9D-A18	T Figure lock Comp.
3	AM-MPT-1100-9D-A03	Bolt	19	AM-MPT-1100-9D-A19	Spring Washer
4	AM-MPT-1100-9D-A04	Nut	20	AM-MPT-1100-9D-A20	NA
5	AM-MPT-1100-9D-A05	Throttle Cable Comp	21	AM-MPT-1100-9D-A21	Bolt
6	AM-MPT-1100-9D-A06	Flameout Switch	22	AM-MPT-1100-9D-A22	Tray Gear
7	AM-MPT-1100-9D-A07	Clip	23	AM-MPT-1100-9D-A23	High And Low Lock Comp.
8	AM-MPT-1100-9D-A08	Pin	24	AM-MPT-1100-9D-A24	Shift Lever
9	AM-MPT-1100-9D-A09	Flameout Switch Seat	25	AM-MPT-1100-9D-A25	Handle Seat Comp
10	AM-MPT-1100-9D-A10	Bolt	26	AM-MPT-1100-9D-A26	Bolt
11	AM-MPT-1100-9D-A11	Flameout Switch cable co	27	AM-MPT-1100-9D-A27	Washer
12	AM-MPT-1100-9D-A12	Reverse Gear or Clutch G	28	AM-MPT-1100-9D-A28	Spring Washer
13	AM-MPT-1100-9D-A13	Pin	29	AM-MPT-1100-9D-A29	Nut
14	AM-MPT-1100-9D-A14	Clutch Pin Cable	30	AM-MPT-1100-9D-A30	Startup Control Cord
15	AM-MPT-1100-9D-A15	Pin	31	AM-MPT-1100-9D-A31	NA
16	AM-MPT-1100-9D-A16	Reverse gear cable	32	AM-MPT-1100-9D-A32	Accumator Fixation Boar

SL NO	PART NO	DESCRIPTION	SL NO	PART NO	DESCRIPTION
33	AM-MPT-1100-9D-A33	NA			
34	AM-MPT-1100-9D-A34	NA			
35	AM-MPT-1100-9D-A35	NA			
36	AM-MPT-1100-9D-A36	NA			
37	AM-MPT-1100-9D-A37	NA			
38	AM-MPT-1100-9D-A38	NA			
39	AM-MPT-1100-9D-A39	NA			
40	AM-MPT-1100-9D-A40	NA			
41	AM-MPT-1100-9D-A41	NA			

KM HANDLE TYPE-3 (Normal Engaged clutch old Type)

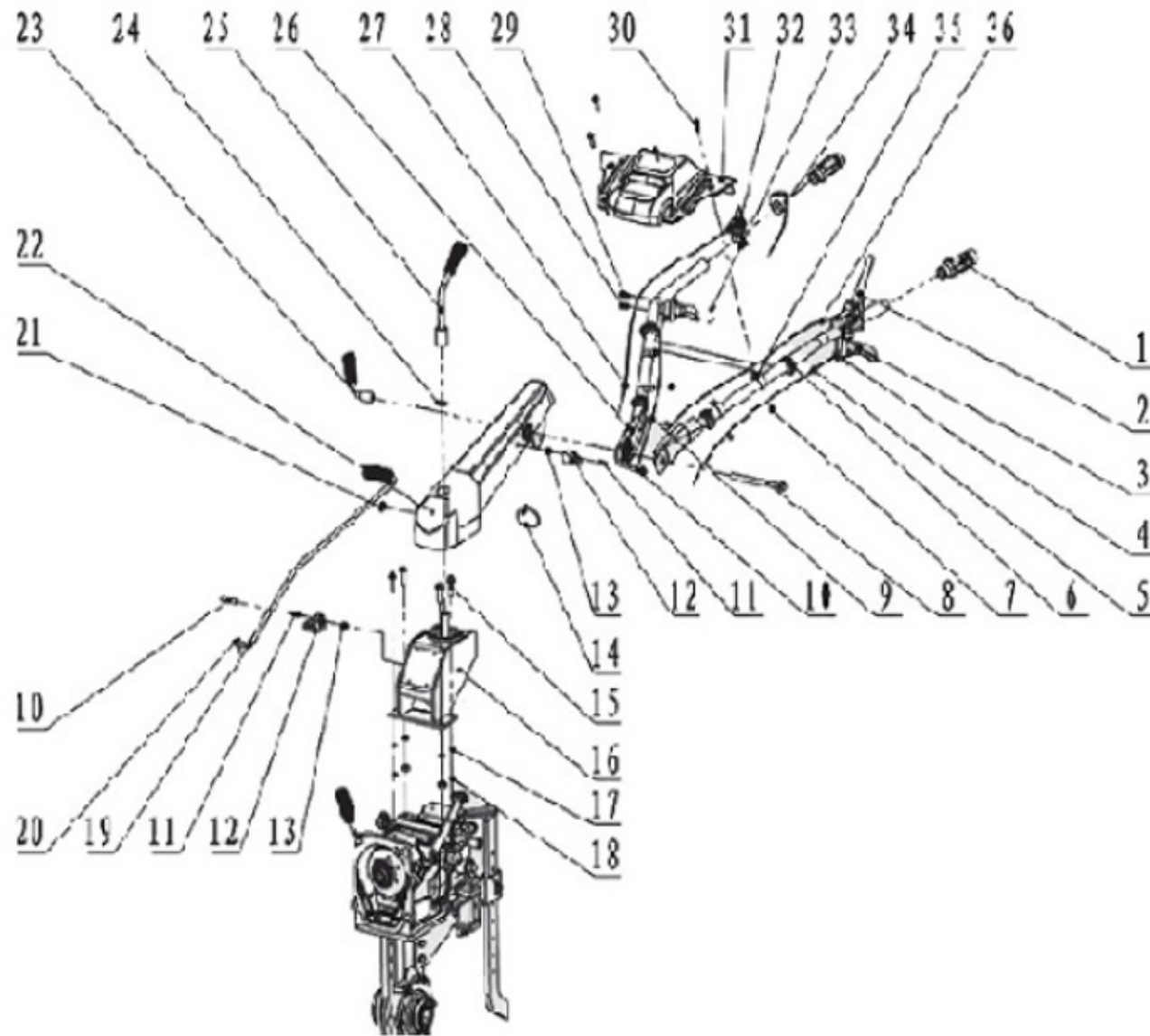

SL NO	PART NO	DESCRIPTION	SL NO	PART NO	DESCRIPTION
1	AM-MPT-1100-9D-FR1	Handle Rubber	19	AM-MPT-1100-9D-FR19	Shift Gear Rod
2	AM-MPT-1100-9D-FR2	Diesel Emergency Stop switch	20	AM-MPT-1100-9D-FR20	Clip B
3	AM-MPT-1100-9D-FR3	Handle	21	AM-MPT-1100-9D-FR21	Plug
4	AM-MPT-1100-9D-FR4	Clutch Clip	22	AM-MPT-1100-9D-FR22	1100A-6 handle seat
5	AM-MPT-1100-9D-FR5	1100A-6 Usually closed Clutch cable	23	AM-MPT-1100-9D-FR23	Locked grip
6	AM-MPT-1100-9D-FR6	Cable Clip	24	AM-MPT-1100-9D-FR24	Spring Washer
7	AM-MPT-1100-9D-FR7	Nut	25	AM-MPT-1100-9D-FR25	Locked turning handle
8	AM-MPT-1100-9D-FR8	Bolt	26	AM-MPT-1100-9D-FR26	1100A-6 handle frame
9	AM-MPT-1100-9D-FR9	1100A-6 reverse cable	27	AM-MPT-1100-9D-FR27	Throttle cable
10	AM-MPT-1100-9D-FR10	Bolt	28	AM-MPT-1100-9D-FR28	Cable tie in
11	AM-MPT-1100-9D-FR11	Sleeve	29	AM-MPT-1100-9D-FR29	Pin
12	AM-MPT-1100-9D-FR12	1100A-6 Shift gear Rod limit block	30	AM-MPT-1100-9D-FR30	Bold
13	AM-MPT-1100-9D-FR13	Locked Nut	31	AM-MPT-1100-9D-FR31	Tool box
14	AM-MPT-1100-9D-FR14	Cable circle	32	AM-MPT-1100-9D-FR32	Oil switch
15	AM-MPT-1100-9D-FR15	Bolt	33	AM-MPT-1100-9D-FR33	Split pin
16	AM-MPT-1100-9D-FR16	1100A 6km Bottom Seat	34	AM-MPT-1100-9D-FR34	NA
17	AM-MPT-1100-9D-FR17	Spring Washer	35	AM-MPT-1100-9D-FR35	Handle frame connection piece
18	AM-MPT-1100-9D-FR18	Nut	36	AM-MPT-1100-9D-FR36	Fameout cable

Transmission Case Comp-A

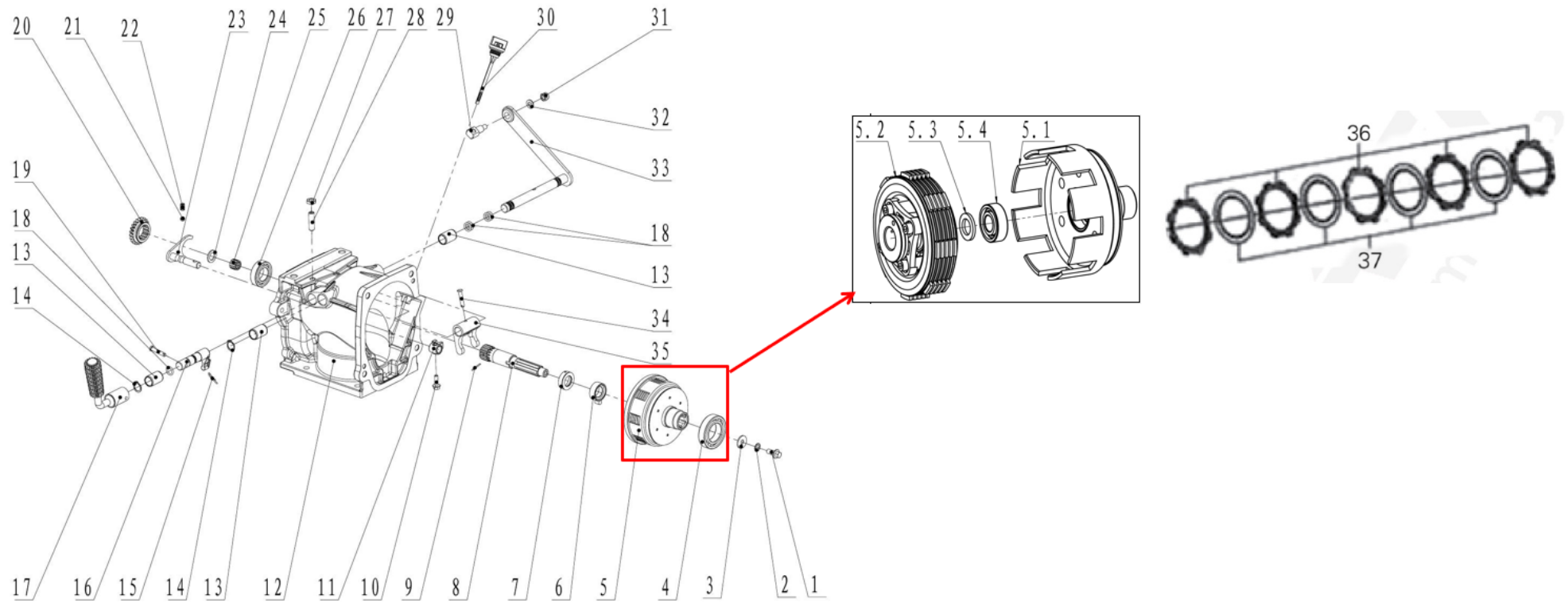

Old Type

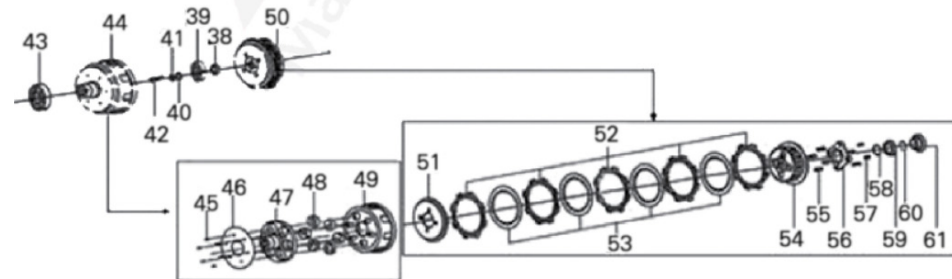

SL NO	PART NO	DESCRIPTION	SL NO	PART NO	DESCRIPTION
1	AM-MPT-1100-9D-TA-01	Bolt	13	AM-MPT-1100-9D-TA-13	Bush
2	AM-MPT-1100-9D-TA-02	Locked washer	14	AM-MPT-1100-9D-TA-14	Spring washer
3	AM-MPT-1100-9D-TA-03	Big washer	15	AM-MPT-1100-9D-TA-15	Circlip F
4	AM-MPT-1100-9D-TA-04	Ball bearing	16	AM-MPT-1100-9D-TA-16	Shift gear rocker
5	AM-MPT-1100-9D-TA-05	Clutch comp	17	AM-MPT-1100-9D-TA-17	Vice speed handle
5.1	AM-MPT-1100-9D-TA-5.1	Clutch cover assembly (spheroidal iron)	18	AM-MPT-1100-9D-TA-18	O-ring
5.2	AM-MPT-1100-9D-TA-5.2	Clutch core assembly (normally open)	19	AM-MPT-1100-9D-TA-19	Pin
5.3	AM-MPT-1100-9D-TA-5.3	Clutch gasket	20	AM-MPT-1100-9D-TA-20	Main shaft gear A
5.4	AM-MPT-1100-9D-TA-5.4	Deep groove ball bearings	21	AM-MPT-1100-9D-TA-21	steel ball
6	AM-MPT-1100-9D-TA-06	T09 Sheath	22	AM-MPT-1100-9D-TA-22	Shift gear spring
7	AM-MPT-1100-9D-TA-07	T09 friction tray	23	AM-MPT-1100-9D-TA-23	Vice speed fork
8	AM-MPT-1100-9D-TA-08	Input shaft	24	AM-MPT-1100-9D-TA-24	Wear washer
9	AM-MPT-1100-9D-TA-09	Split pin	25	AM-MPT-1100-9D-TA-25	Needle bearing
10	AM-MPT-1100-9D-TA-10	Bolt	26	AM-MPT-1100-9D-TA-26	Ball bearing
11	AM-MPT-1100-9D-TA-11	Vice speed striker	27	AM-MPT-1100-9D-TA-27	Thin nut
12	AM-MPT-1100-9D-TA-12	Transmission case	28	AM-MPT-1100-9D-TA-28	Pointless set screw

SL NO	PART NO	DESCRIPTION	SL NO	PART NO	DESCRIPTION
29	AM-MPT-1100-9D-TA-29	Clutch cable seat	45	AM-MPT-1100-9D-TA-45	NA
30	AM-MPT-1100-9D-TA-30	Oil ruler	46	AM-MPT-1100-9D-TA-46	NA
31	AM-MPT-1100-9D-TA-31	Locked nut	47	AM-MPT-1100-9D-TA-47	NA
32	AM-MPT-1100-9D-TA-32	Washer	48	AM-MPT-1100-9D-TA-48	NA
33	AM-MPT-1100-9D-TA-33	Clutch	49	AM-MPT-1100-9D-TA-49	NA
34	AM-MPT-1100-9D-TA-34	Pin	50	AM-MPT-1100-9D-TA-50	NA
35	AM-MPT-1100-9D-TA-35	Clutch fork	51	AM-MPT-1100-9D-TA-51	NA
36	AM-MPT-1100-9D-TA-36	NA	52	AM-MPT-1100-9D-TA-52	NA
37	AM-MPT-1100-9D-TA-37	NA	53	AM-MPT-1100-9D-TA-53	NA
38	AM-MPT-1100-9D-TA-38	NA	54	AM-MPT-1100-9D-TA-54	NA
39	AM-MPT-1100-9D-TA-39	NA	55	AM-MPT-1100-9D-TA-55	NA
40	AM-MPT-1100-9D-TA-40	NA	56	AM-MPT-1100-9D-TA-56	NA
41	AM-MPT-1100-9D-TA-41	NA	57	AM-MPT-1100-9D-TA-57	NA
42	AM-MPT-1100-9D-TA-42	NA	58	AM-MPT-1100-9D-TA-58	NA
43	AM-MPT-1100-9D-TA-43	NA	59	AM-MPT-1100-9D-TA-59	NA
44	AM-MPT-1100-9D-TA-44	NA	60	AM-MPT-1100-9D-TA-60	NA
			61	AM-MPT-1100-9D-TA-61	NA

Transmission Back Case Comp- B

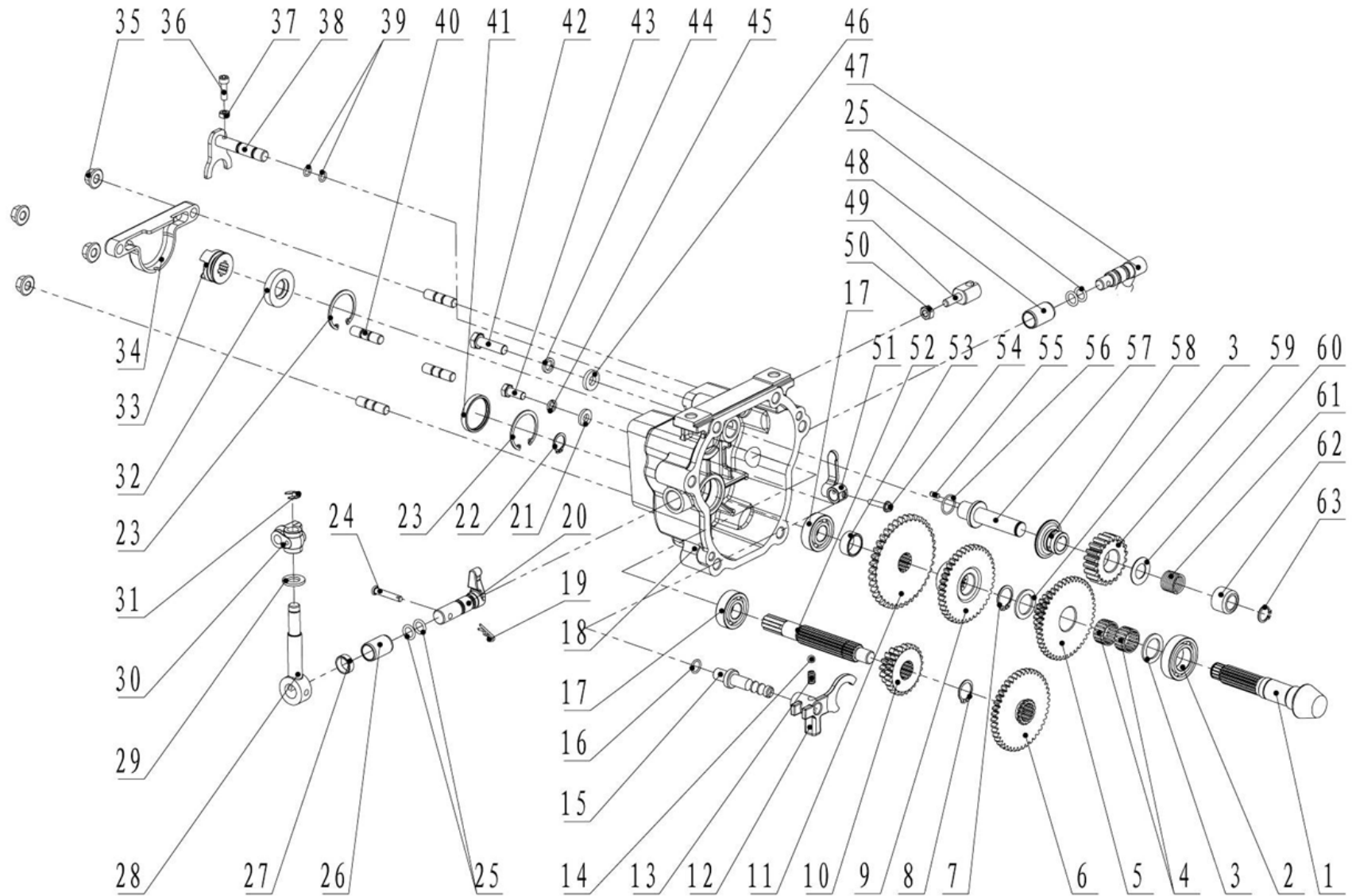

SL NO	PART NO	DESCRIPTION	SL NO	PART NO	DESCRIPTION
1	AM-MPT-1100-9D-TB-01	Vice shaft	17	AM-MPT-1100-9D-TB-17	Ball bearing
2	AM-MPT-1100-9D-TB-02	Ball bearing	18	AM-MPT-1100-9D-TB-18	Back case cover
3	AM-MPT-1100-9D-TB-03	Adjustment washer	19	AM-MPT-1100-9D-TB-19	Circlip F
4	AM-MPT-1100-9D-TB-04	Needle bearing	20	AM-MPT-1100-9D-TB-20	Shif gear rocker
5	AM-MPT-1100-9D-TB-05	Vice shaft double teeth gear A	21	AM-MPT-1100-9D-TB-21	Gasket
6	AM-MPT-1100-9D-TB-06	Main shaft gear B	22	AM-MPT-1100-9D-TB-22	Spring washer
7	AM-MPT-1100-9D-TB-07	Spring washer	23	AM-MPT-1100-9D-TB-23	Ring for hole
8	AM-MPT-1100-9D-TB-08	Spring washer	24	AM-MPT-1100-9D-TB-24	Pin
9	AM-MPT-1100-9D-TB-09	Vice shaft fast gear	25	AM-MPT-1100-9D-TB-25	O-ring
10	AM-MPT-1100-9D-TB-10	Main shaft double teeth gear	26	AM-MPT-1100-9D-TB-26	Bush
11	AM-MPT-1100-9D-TB-11	Vice shaft slow gear	27	AM-MPT-1100-9D-TB-27	Restrict sheath
12	AM-MPT-1100-9D-TB-12	Shift gear fork	28	AM-MPT-1100-9D-TB-28	Shift gear sheath
13	AM-MPT-1100-9D-TB-13	Shift gear spring	29	AM-MPT-1100-9D-TB-29	Gasket
14	AM-MPT-1100-9D-TB-14	steel ball	30	AM-MPT-1100-9D-TB-30	PTO gemel B
15	AM-MPT-1100-9D-TB-15	Shift gear fork shaft	31	AM-MPT-1100-9D-TB-31	Split washer
16	AM-MPT-1100-9D-TB-16	O-ring	32	AM-MPT-1100-9D-TB-32	Lip seal

SL NO	PART NO	DESCRIPTION	SL NO	PART NO	DESCRIPTION
33	AM-MPT-1100-9D-TB-33	Output slutch push dog	49	AM-MPT-1100-9D-TB-49	Reverse cable seat
34	AM-MPT-1100-9D-TB-34	Plastic clutch cover	50	AM-MPT-1100-9D-TB-50	Bolt
35	AM-MPT-1100-9D-TB-35	Nut	51	AM-MPT-1100-9D-TB-51	Reverse fork
36	AM-MPT-1100-9D-TB-36	Bolt	52	AM-MPT-1100-9D-TB-52	Main shaft
37	AM-MPT-1100-9D-TB-37	Nut	53	AM-MPT-1100-9D-TB-53	Sheath
38	AM-MPT-1100-9D-TB-38	Output fork	54	AM-MPT-1100-9D-TB-54	Bolt
39	AM-MPT-1100-9D-TB-39	O-rng	55	AM-MPT-1100-9D-TB-55	Cylindrical pin
40	AM-MPT-1100-9D-TB-40	Stud bolt	56	AM-MPT-1100-9D-TB-56	O-ring
41	AM-MPT-1100-9D-TB-41	Oil plug	57	AM-MPT-1100-9D-TB-57	Reverse shaft
42	AM-MPT-1100-9D-TB-42	Bolt	58	AM-MPT-1100-9D-TB-58	Reverse push plate
43	AM-MPT-1100-9D-TB-43	Bolt	59	AM-MPT-1100-9D-TB-59	Reverse gear
44	AM-MPT-1100-9D-TB-44	Spring washer	60	AM-MPT-1100-9D-TB-60	Wear washer
45	AM-MPT-1100-9D-TB-45	Spring washer	61	AM-MPT-1100-9D-TB-61	Reverse spring
46	AM-MPT-1100-9D-TB-46	Reverse gear shaft washer	62	AM-MPT-1100-9D-TB-62	Reverse restrict sheath
47	AM-MPT-1100-9D-TB-47	Reverse gear fork shaft	63	AM-MPT-1100-9D-TB-63	Spring washer
48	AM-MPT-1100-9D-TB-48	Fork sheath			

Transmission Back Case Comp- BN (New Improved)

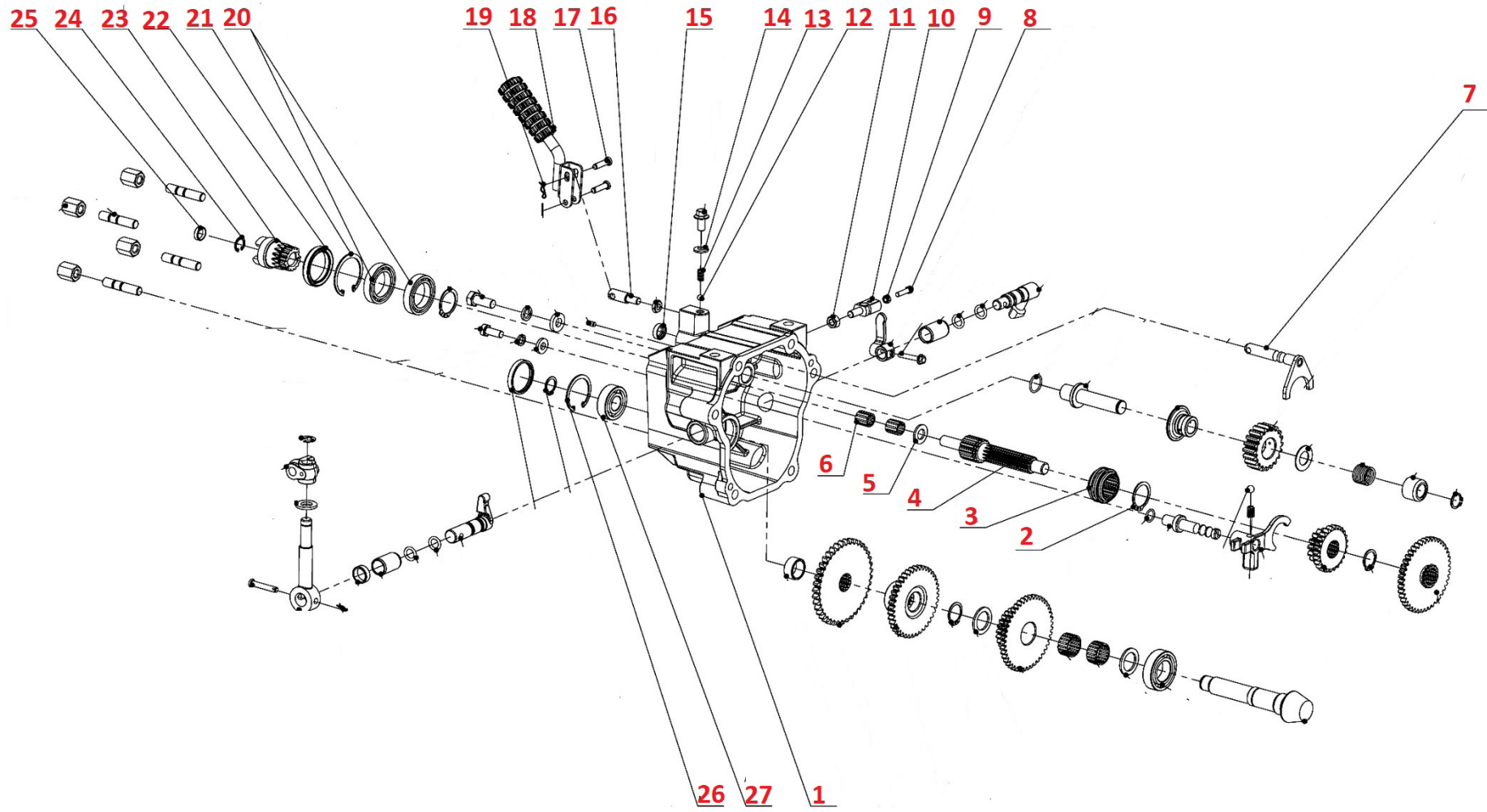

SL NO	PART NO	DESCRIPTION	SL NO	PART NO	DESCRIPTION
1	AM-MPT-1100-9D-TBN-01	Transmission case back cover	17	AM-MPT-1100-9D-TBN-17	Pin
2	AM-MPT-1100-9D-TBN-02	Shaft circlip	18	AM-MPT-1100-9D-TBN-18	output clutch handle
3	AM-MPT-1100-9D-TBN-03	Coupling sleeve	19	AM-MPT-1100-9D-TBN-19	circlip A
4	AM-MPT-1100-9D-TBN-04	Spindle	20	AM-MPT-1100-9D-TBN-20	Deep groove ball bearing
5	AM-MPT-1100-9D-TBN-05	Wear washer	21	AM-MPT-1100-9D-TBN-21	Circlips for holes
6	AM-MPT-1100-9D-TBN-06	Needle bearing	22	AM-MPT-1100-9D-TBN-22	Oil seal
7	AM-MPT-1100-9D-TBN-07	Output clutch fork	23	AM-MPT-1100-9D-TBN-23	PTO shaft
8	AM-MPT-1100-9D-TBN-08	Hexagon head bolt	24	AM-MPT-1100-9D-TBN-24	Circlips for holes
9	AM-MPT-1100-9D-TBN-09	Hex Nut	25	AM-MPT-1100-9D-TBN-25	Oil plug
10	AM-MPT-1100-9D-TBN-10	clutch cable seat	26	AM-MPT-1100-9D-TBN-26	Circlips for holes
11	AM-MPT-1100-9D-TBN-11	Hex Nut	27	AM-MPT-1100-9D-TBN-27	Deep groove ball bearing
12	AM-MPT-1100-9D-TBN-12	Steel ball			
13	AM-MPT-1100-9D-TBN-13	Gear spring			
14	AM-MPT-1100-9D-TBN-14	Gasket			
15	AM-MPT-1100-9D-TBN-15	Non-standard oil seal			
16	AM-MPT-1100-9D-TBN-16	support rod			

Transmission Back case comp- C

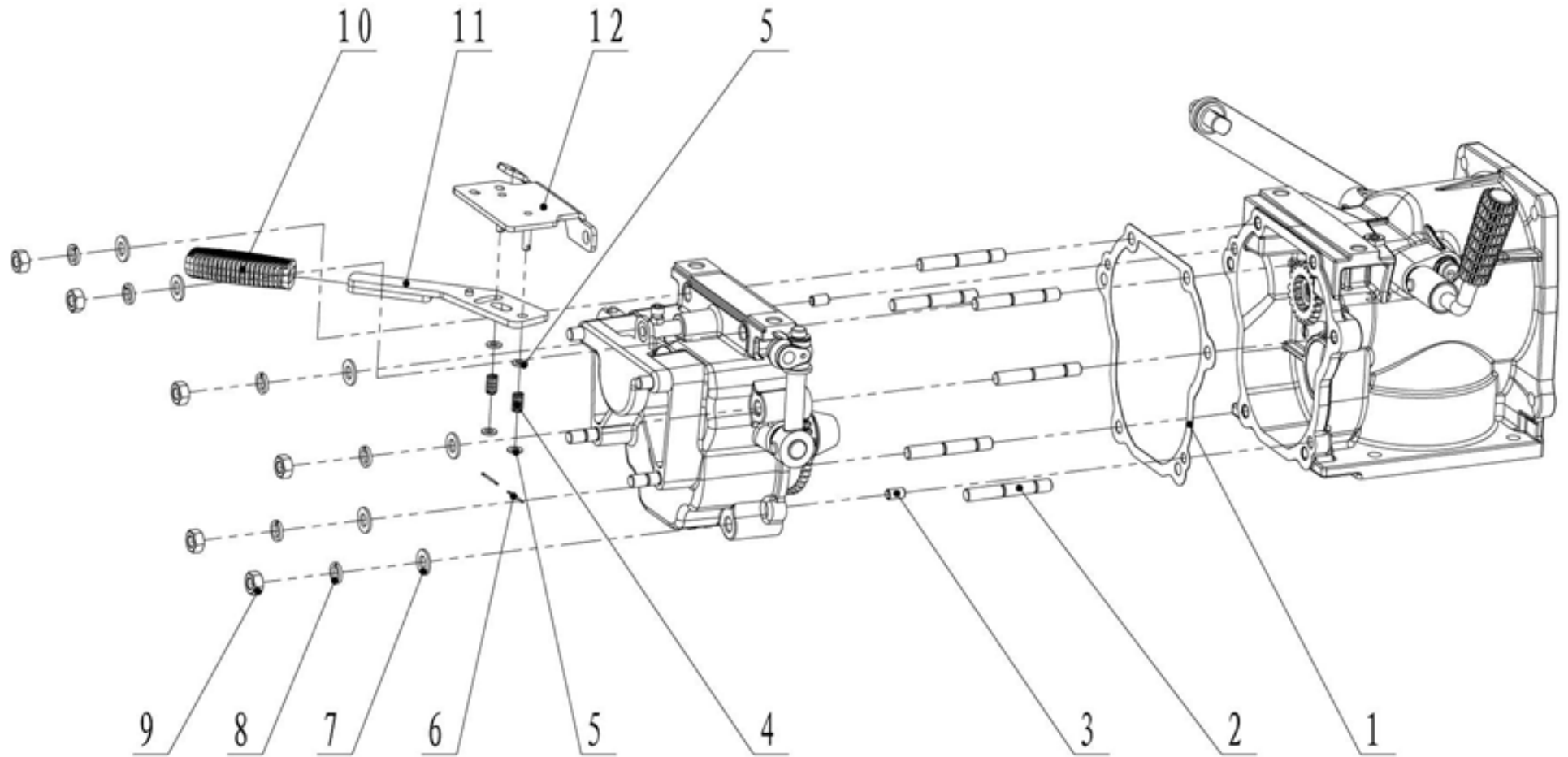

SL NO	PART NO	DESCRIPTION	SL NO	PART NO	DESCRIPTION
1	AM-MPT-1100-9D-TC-01	Combination gasket			
2	AM-MPT-1100-9D-TC-02	Stud bolt			
3	AM-MPT-1100-9D-TC-03	Dowel pin			
4	AM-MPT-1100-9D-TC-04	Output clutch srping			
5	AM-MPT-1100-9D-TC-05	Washer			
6	AM-MPT-1100-9D-TC-06	Split pin			
7	AM-MPT-1100-9D-TC-07	Washer			
8	AM-MPT-1100-9D-TC-08	Spring washer			
9	AM-MPT-1100-9D-TC-09	Nut			
10	AM-MPT-1100-9D-TC-10	Handle rubber			
11	AM-MPT-1100-9D-TC-11	Output clutch grip			
12	AM-MPT-1100-9D-TC-12	Output clutch frame			

Transmission combination parts- C N (New Improved)

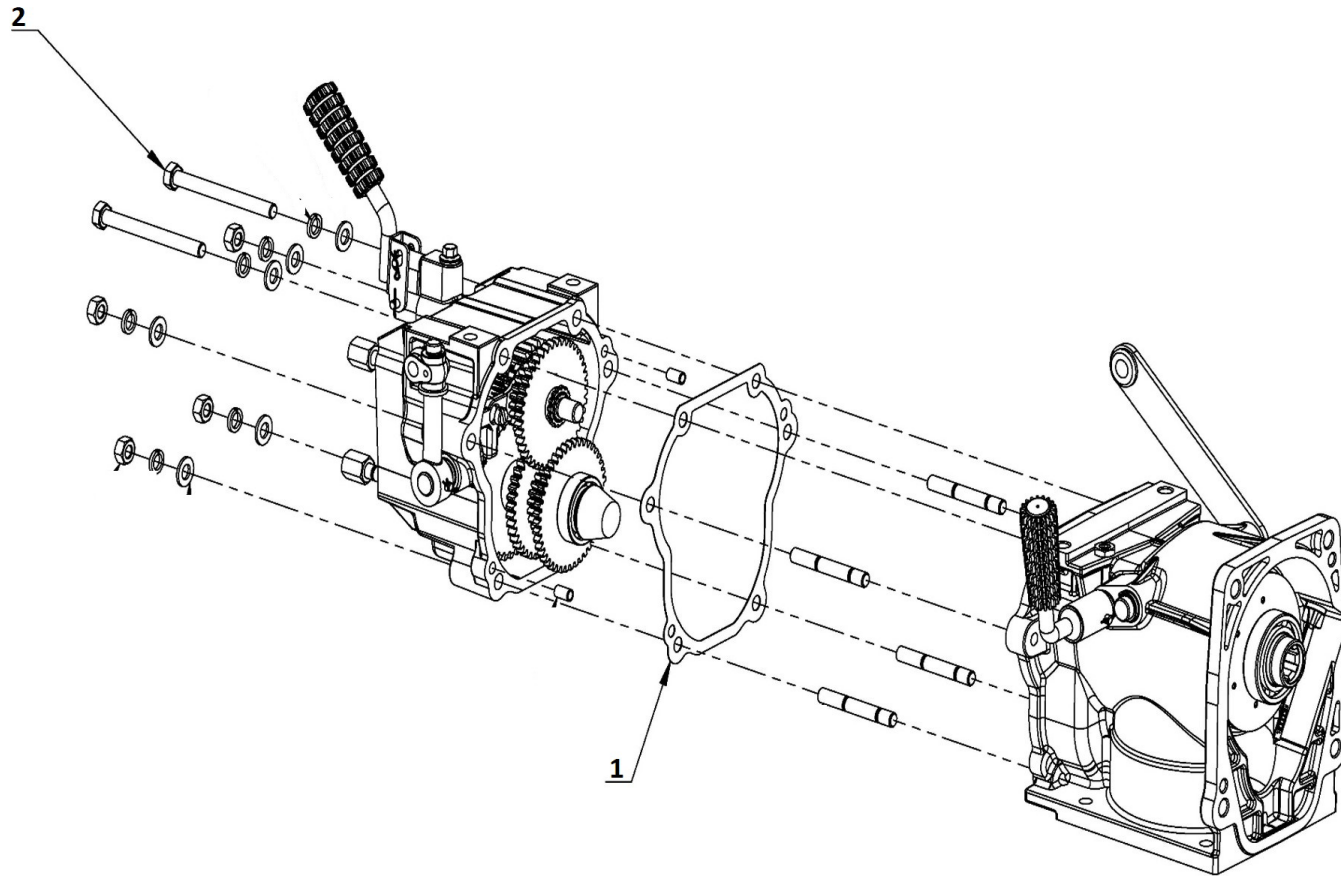

SL NO	PART NO	DESCRIPTION
1	AM-MPT-1100-9D-TCN-01	Back cover closing paper pad
2	AM-MPT-1100-9D-TCN-02	Hexagon head bolt

Walking case comp - D

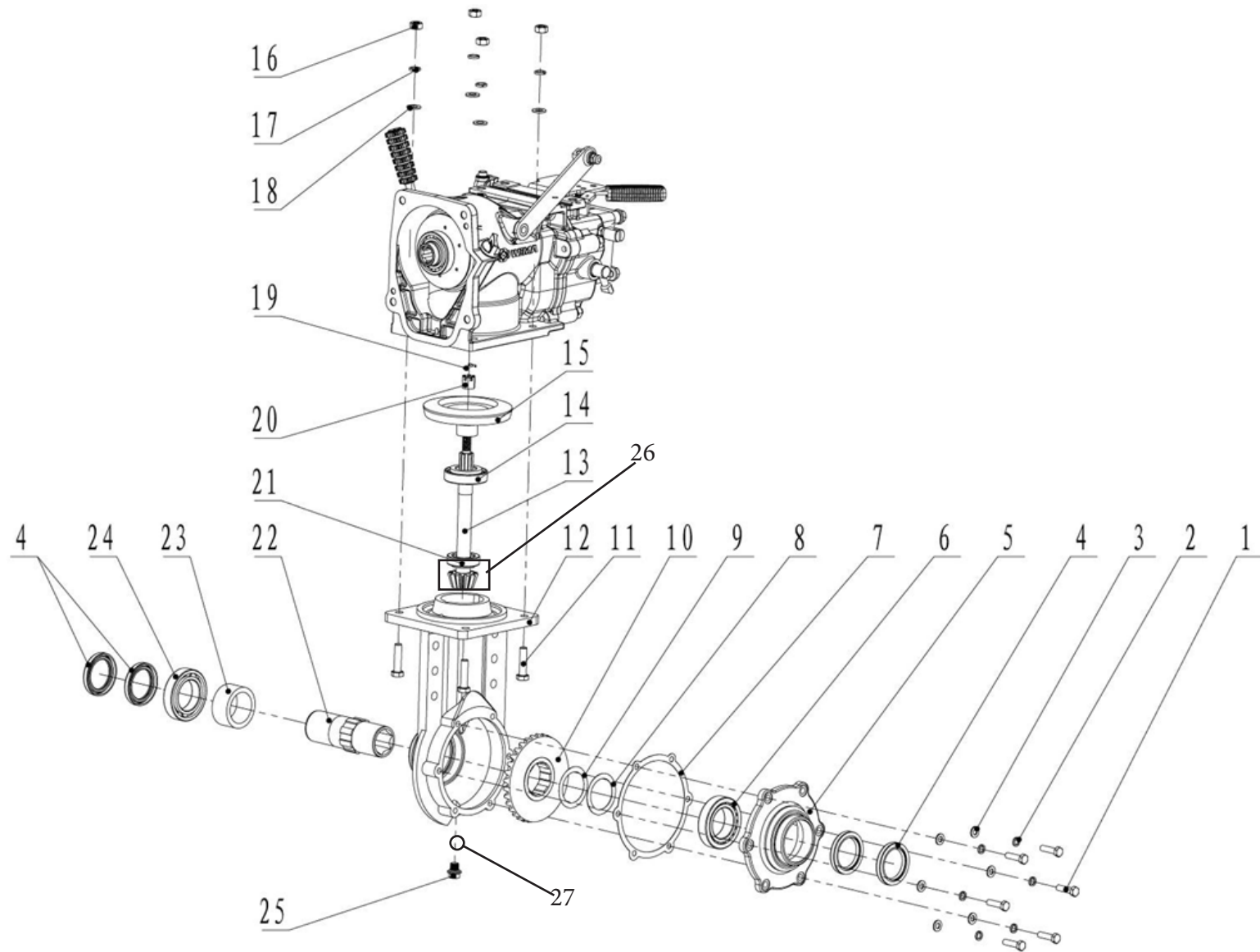

SL NO	PART NO	DESCRIPTION	SL NO	PART NO	DESCRIPTION
1	AM-MPT-1100-9D-TD-01	Bolt	17	AM-MPT-1100-9D-TD-17	Spring washer
2	AM-MPT-1100-9D-TD-02	Spring washer	18	AM-MPT-1100-9D-TD-18	Gasket
3	AM-MPT-1100-9D-TD-03	Gasket	19	AM-MPT-1100-9D-TD-19	Split pin
4	AM-MPT-1100-9D-TD-04	Lip seal	20	AM-MPT-1100-9D-TD-20	Slotted nut
5	AM-MPT-1100-9D-TD-05	Walking case end cover	21	AM-MPT-1100-9D-TD-21	Tapped roller bearing
6	AM-MPT-1100-9D-TD-06	Tapped roller bearing	22	AM-MPT-1100-9D-TD-22	Inner haxed output sheath
7	AM-MPT-1100-9D-TD-07	End cover gasket	23	AM-MPT-1100-9D-TD-23	Output shaft sheath
8	AM-MPT-1100-9D-TD-08	Adjustment gasket	24	AM-MPT-1100-9D-TD-24	Ball bearing
9	AM-MPT-1100-9D-TD-09	Adjustment gasket	25	AM-MPT-1100-9D-TD-25	Drain bolt
10	AM-MPT-1100-9D-TD-10	Walking umbrella gear	26	AM-MPT-1100-9D-TD-26	Gasket of walking case
11	AM-MPT-1100-9D-TAD-11	Bolt	27	AM-MPT-1100-9D-TD-27	O -ring
12	AM-MPT-1100-9D-TD-12	Walking case			
13	AM-MPT-1100-9D-TD-13	Umbrella gear shaft			
14	AM-MPT-1100-9D-TD-14	Tapped roller bearing			
15	AM-MPT-1100-9D-TD-15	Driven umbrella gear			
16	AM-MPT-1100-9D-TD-16	Bolt			

Tow Bar Comp -E

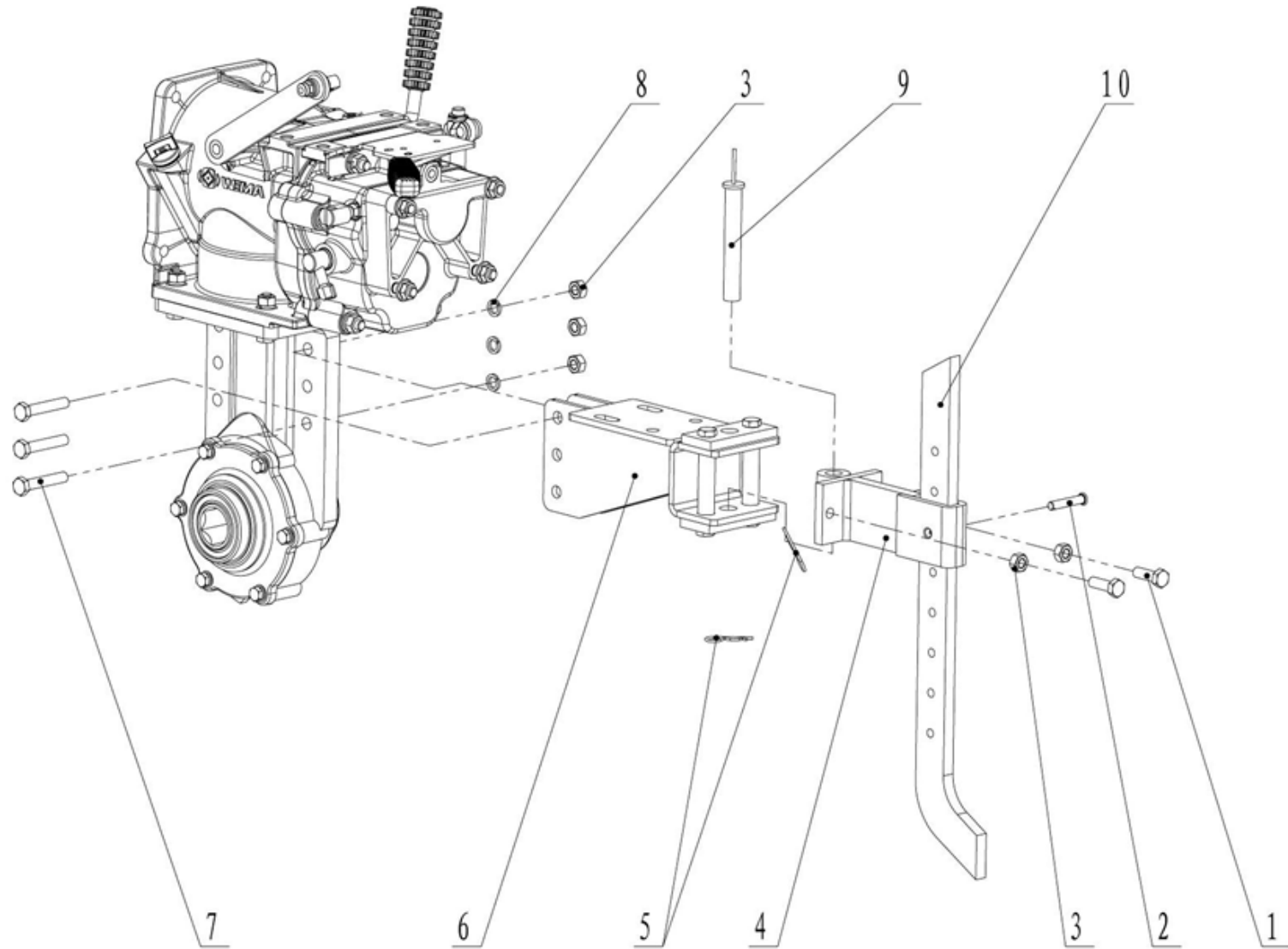

KM handle Bar Comp(Usually open clutch) -F

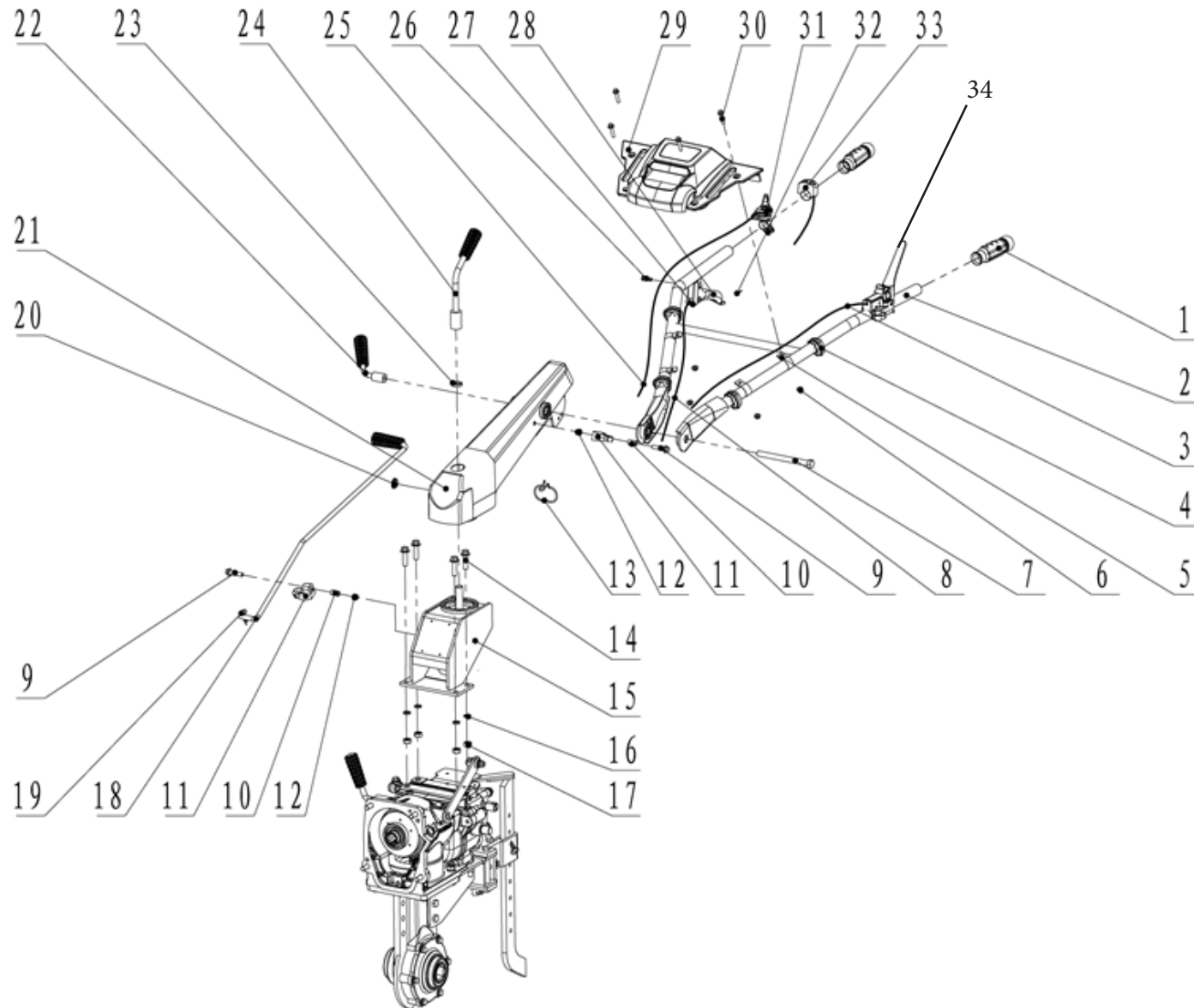

SL NO	PART NO	DESCRIPTION	SL NO	PART NO	DESCRIPTION
1	AM-MPT-1100-9D-TF-01	handle rubber	18	AM-MPT-1100-9D-TAF-18	Shift gear rod
2	AM-MPT-1100-9D-TF-02	Handle frame	19	AM-MPT-1100-9D-TF-19	Clip B
3	AM-MPT-1100-9D-TF-03	Ill usually open clutch cable	20	AM-MPT-1100-9D-TF-20	Plug
4	AM-MPT-1100-9D-TF-04	Cable clip	21	AM-MPT-1100-9D-TF-21	handle seat
5	AM-MPT-1100-9D-TF-05	Handle fram connection piece	22	AM-MPT-1100-9D-TF-22	Locked grip
6	AM-MPT-1100-9D-TF-06	Nut	23	AM-MPT-1100-9D-TF-23	Spring washer
7	AM-MPT-1100-9D-TF-07	Bolt	24	AM-MPT-1100-9D-TF-24	Locked turning handel
8	AM-MPT-1100-9D-TF-08	reverse cable	25	AM-MPT-1100-9D-TF-25	Oil cable
9	AM-MPT-1100-9D-TF-09	Bolt	26	AM-MPT-1100-9D-TF-26	Pin
10	AM-MPT-1100-9D-TF-10	Sleeve	27	AM-MPT-1100-9D-TF-27	Reverse locked grip
11	AM-MPT-1100-9D-TF-11	Shift gear rod limit block	28	AM-MPT-1100-9D-TF-28	Reverse grip
12	AM-MPT-1100-9D-TF-12	Locked nut	29	AM-MPT-1100-9D-TF-29	Tool box
13	AM-MPT-1100-9D-TF-13	Cable circle	30	AM-MPT-1100-9D-TF-30	Bolt
14	AM-MPT-1100-9D-TF-14	Bolt	31	AM-MPT-1100-9D-TF-31	Oil switch
15	AM-MPT-1100-9D-TF-15	buttom seat	32	AM-MPT-1100-9D-TF-32	Split
16	AM-MPT-1100-9D-TF-16	Spring washer	33	AM-MPT-1100-9D-TF-33	Flame out Switch(With cable)
17	AM-MPT-1100-9D-TF-17	Nut	34	AM-MPT-1100-9D-TF-34	CLUTCH LEVER

Engine and connections- GG

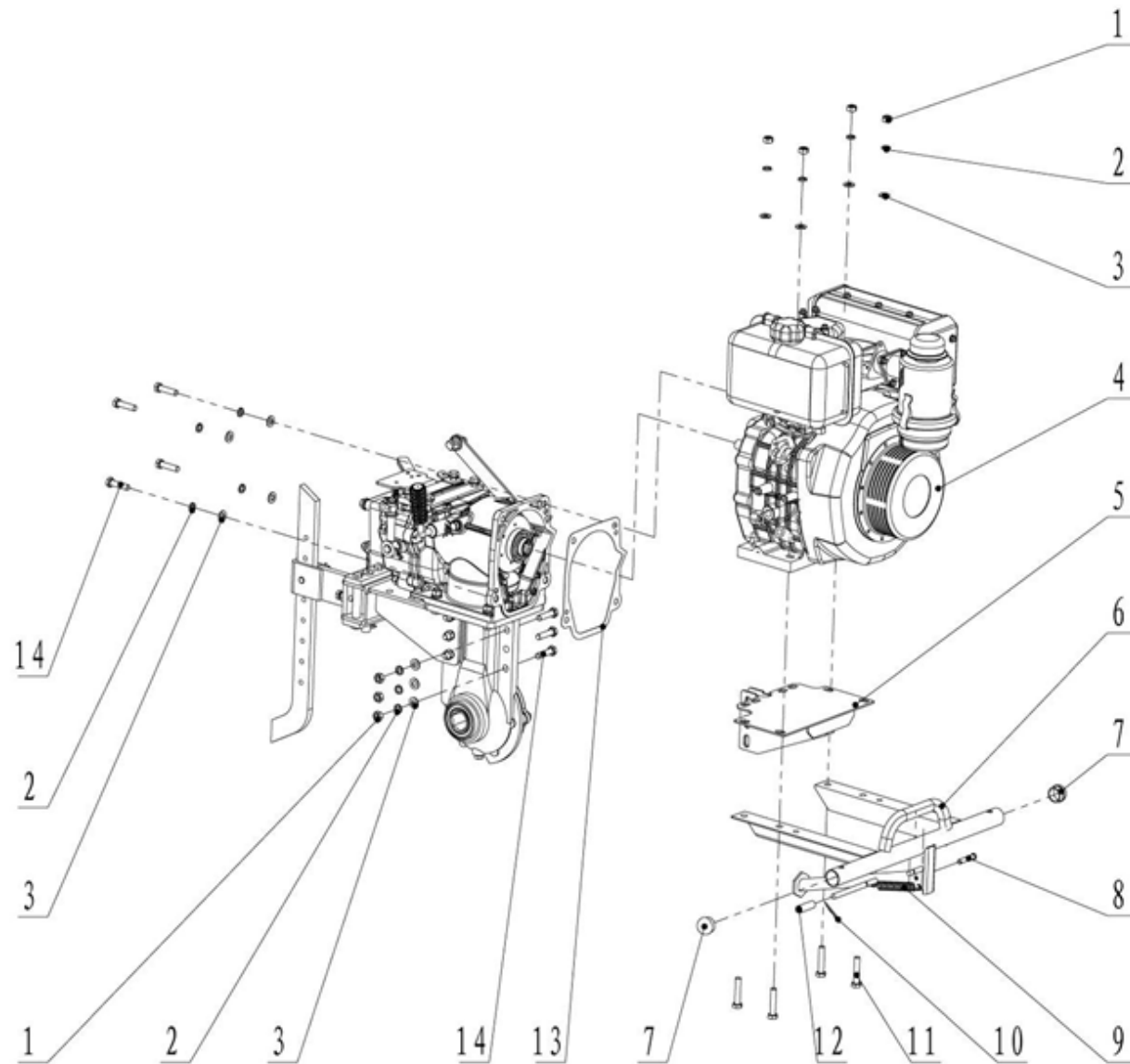

SL NO	PART NO	DESCRIPTION	SL NO	PART NO	DESCRIPTION
1	AM-MPT-1100-9D-TGG-01	Nut			
2	AM-MPT-1100-9D-TGG-02	Spring Washer			
3	AM-MPT-1100-9D-TGG-03	Gasket			
4	AM-MPT-1100-9D-TGG-04	AM- 178F diesel engine for 6D			
		AM-186FB diesel engine for 9D			
5	AM-MPT-1100-9D-TGG-05	Engine frame for 6D			
		Engine frame for 9D			
6	AM-MPT-1100-9D-TGG-06	Bumper for 6D			
		Bumper for 9D			
7	AM-MPT-1100-9D-TGG-07	Bumper stud			
8	AM-MPT-1100-9D-TGG-08	Pin			
9	AM-MPT-1100-9D-TGG-09	Bumper supporter drawing spring			
10	AM-MPT-1100-9D-TGG-10	Clip B			
11	AM-MPT-1100-9D-TGG-11	Bolt			
12	AM-MPT-1100-9D-TGG-12	Small shake handle			
13	AM-MPT-1100-9D-TGG-13	II flange gasket			
14	AM-MPT-1100-9D-TGG-14	Bolt			

Engine & Connections - H

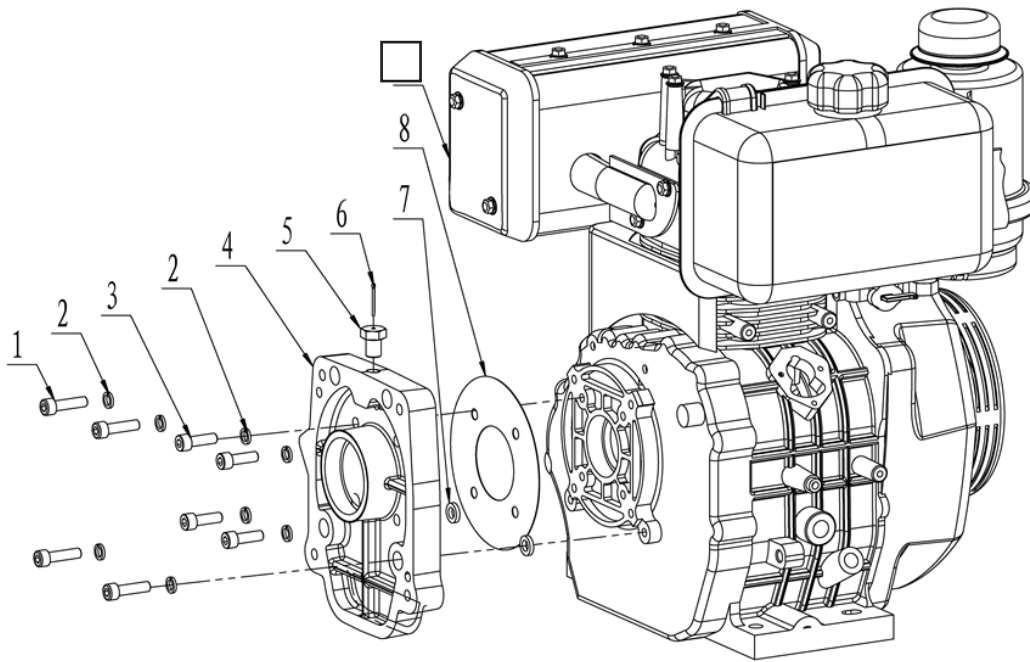

SL NO	PART NO	DESCRIPTION
1	AM-MPT-1100-9D-TH-01	Hexagon socket head screw
2	AM-MPT-1100-9D-TH-02	Spring washer
3	AM-MPT-1100-9D-TH-03	Hexagon socket head screw
4	AM-MPT-1100-9D-TH-04	2nd generation diesel engine flange
5	AM-MPT-1100-9D-TH-05	2nd generation pressure relief bolt
6	AM-MPT-1100-9D-TH-06	Split pin
7	AM-MPT-1100-9D-TH-07	Gasket
8	AM-MPT-1100-9D-TH-08	Flange gasket

Fender parts - J

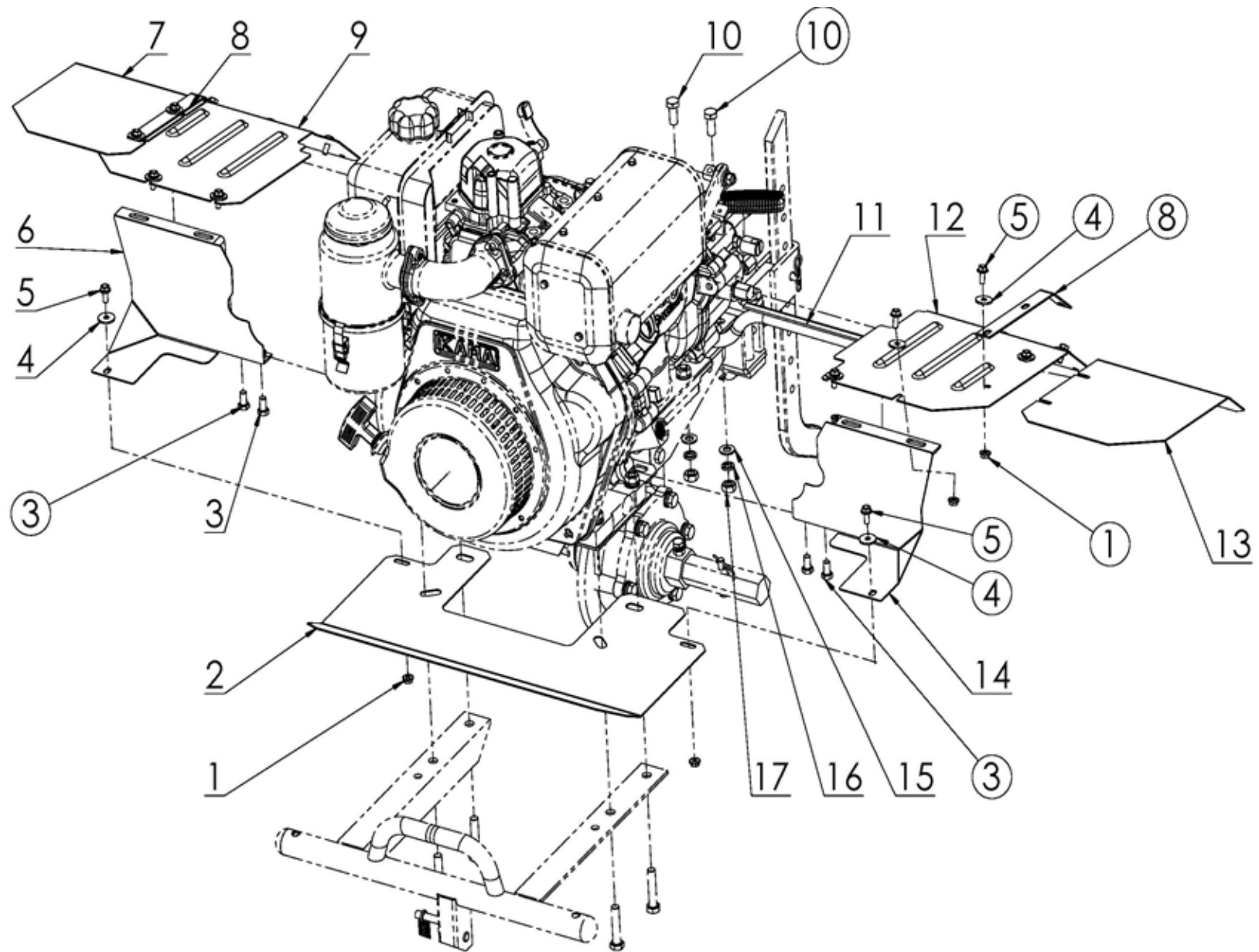

SL NO	PART NO	DESCRIPTION	SL NO	PART NO	DESCRIPTION
1	AM-MPT-1100-9D-TJ-01	Nut	17	AM-MPT-1100-9D-TJ-17	Nut
2	AM-MPT-1100-9D-TJ-02	Front fender			
3	AM-MPT-1100-9D-TJ-03	Bolt			
4	AM-MPT-1100-9D-TJ-04	Big gasket			
5	AM-MPT-1100-9D-TJ-05	Bolt			
6	AM-MPT-1100-9D-TJ-06	Il dust fender right frame(Higher)			
7	AM-MPT-1100-9D-TJ-07	Right vice fender			
8	AM-MPT-1100-9D-TJ-08	Press piece			
9	AM-MPT-1100-9D-TJ-09	Right fender			
10	AM-MPT-1100-9D-TJ-10	Bolt			
11	AM-MPT-1100-9D-TJ-11	Dust fender back frame(Higher)			
12	AM-MPT-1100-9D-TJ-12	Left fender			
13	AM-MPT-1100-9D-TJ-13	Left fender			
14	AM-MPT-1100-9D-TJ-14	Il dust fender left frame(Higher)			
15	AM-MPT-1100-9D-TJ-15	Gasket			
16	AM-MPT-1100-9D-TJ-16	Spring washer			

WHEEL PARTS - K

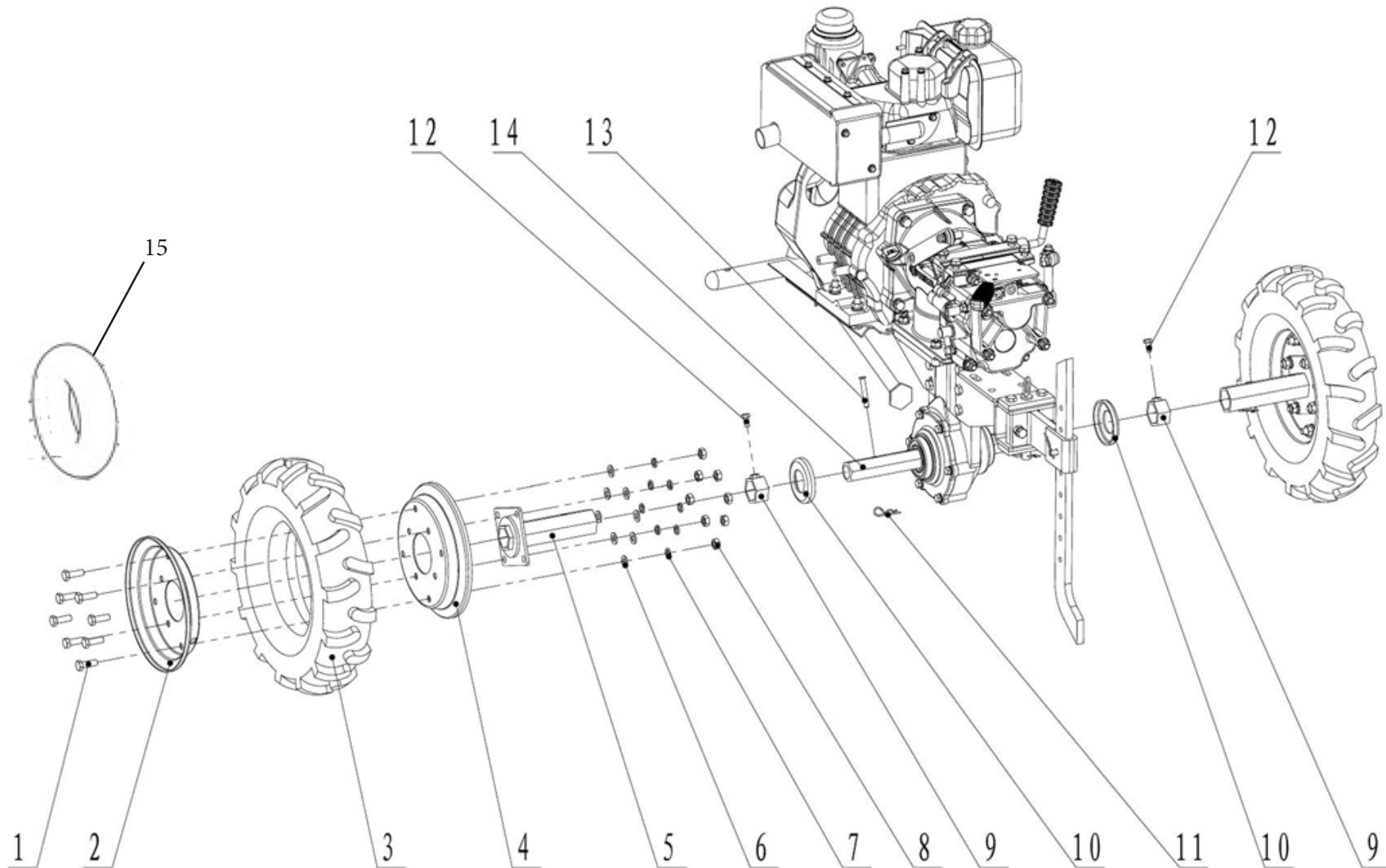

SL NO	PART NO	DESCRIPTION	SL NO	PART NO	DESCRIPTION
1	AM-MPT-1100-9D-TK-01	Bolt	12	AM-MPT-1100-9D-TK-12	Bolt
2A	AM-MPT-1100-9D-TK-02A	Outside rim(with hole) (4.5X10)	13	AM-MPT-1100-9D-TK-13	Pin
2B	AM-MPT-1100-9D-TK-02B	Outside rim(with hole)(5.0X12)	14	AM-MPT-1100-9D-TK-14	Hexagon output shaft
3A	AM-MPT-1100-9D-TK-03A	Wheel and tyre (4.5X10)	15	AM-MPT-1100-9D-TK-15	Inner Tube 4.5 x10
3B	AM-MPT-1100-9D-TK-03B	Wheel and tyre (5.0X12)	16	AM-MPT-1100-9D-TK-15	Inner Tube 5.0X12
4A	AM-MPT-1100-9D-TK-04A	Inner rim (4.5X10)			
4B	AM-MPT-1100-9D-TK-04B	Inner rim (5.0X12)			
5A	AM-MPT-1100-9D-TK-05A	Wheel axle (4.5X10)			
5B	AM-MPT-1100-9D-TK-05B	Wheel axle (5.0X12)			
6	AM-MPT-1100-9D-TK-06	Washer			
7	AM-MPT-1100-9D-TK-07	Spring washer			
8	AM-MPT-1100-9D-TK-08	Nut			
9	AM-MPT-1100-9D-TK-09	Hexagon fasten sheath			
10	AM-MPT-1100-9D-TK-10	Dustproof cover			
11	AM-MPT-1100-9D-TK-11	Clip B			

ROTARY PARTS - L

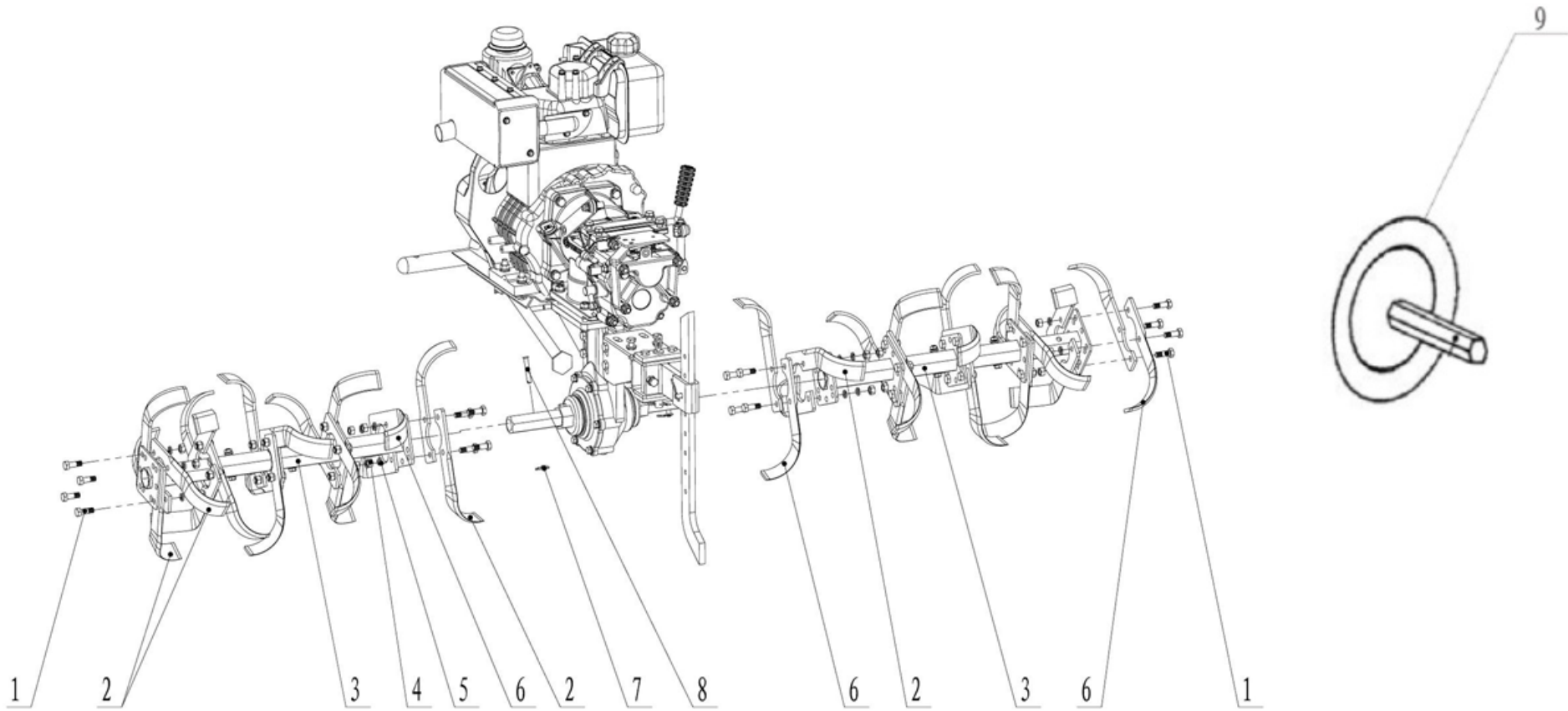

SL NO	PART NO	DESCRIPTION	SL NO	PART NO	DESCRIPTION
1	AM-MPT-1100-9D-TL-01	Bolt			
		Bolt			
2	AM-MPT-1100-9D-TL-02	Right blades			
		Right blades			
3	AM-MPT-1100-9D-TL-03A	3+1 cylinder for 6D			
	AM-MPT-1100-9D-TL-03B	3+1+1 cylinder for 9D			
4	AM-MPT-1100-9D-TL-04	Spring washer 10			
		Spring washer 10			
5	AM-MPT-1100-9D-TL-05	Nut			
		Nut			
6	AM-MPT-1100-9D-TL-06	Left blades			
		Left blades			
7	AM-MPT-1100-9D-TL-07	Clip B			
8	AM-MPT-1100-9D-TL-08	Pin			
9	AM-MPT-1100-9D-TL-09	Round plate			
10	AM-MPT-1100-9D-TL-10	2+1+1 blade Holders			



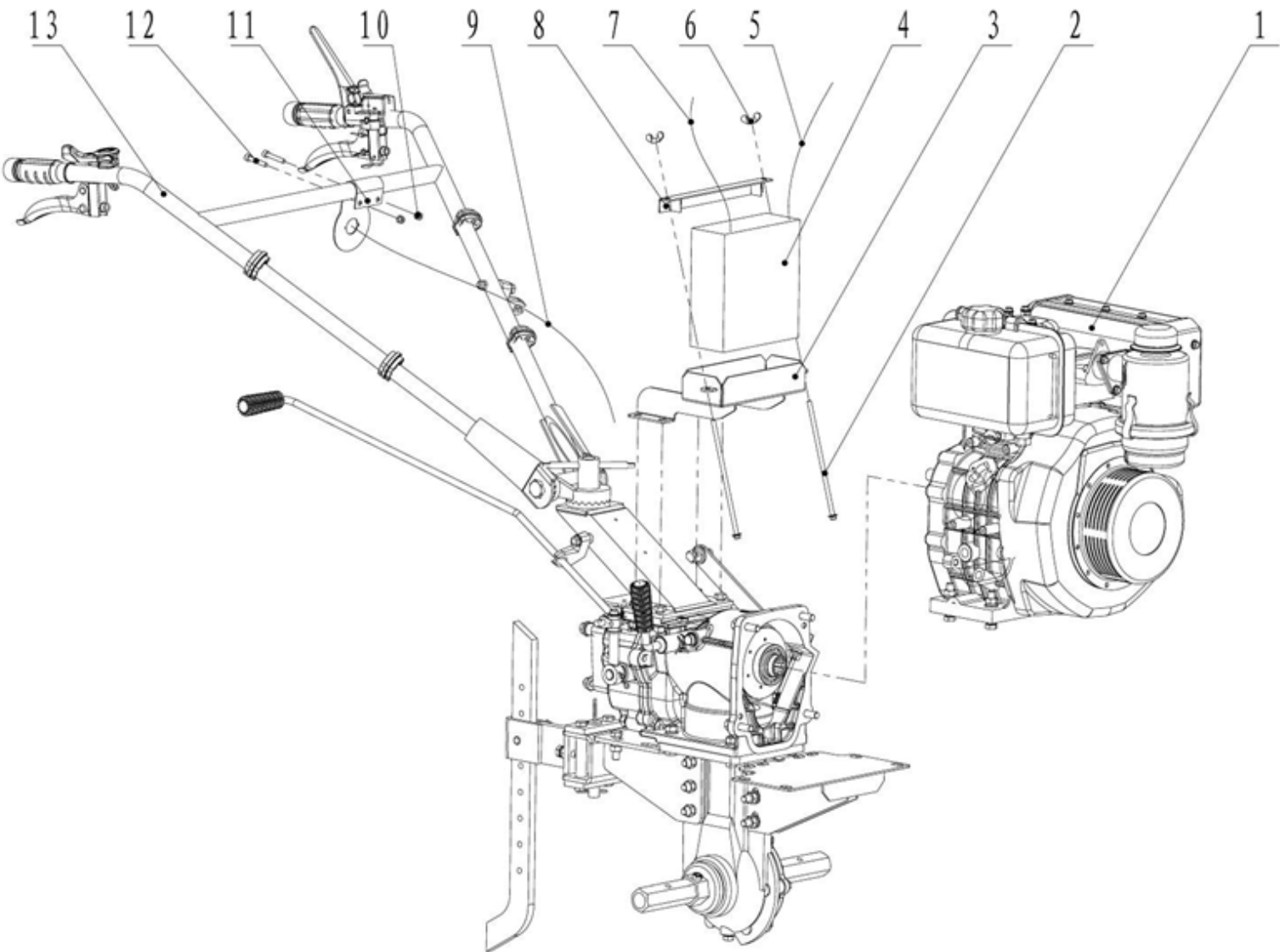

ELECTRIC START -M



SL NO	PART NO	DESCRIPTION	SL NO	PART NO	DESCRIPTION
1	AM-MPT-1100-9D-TM-01A	178FE diesel engine			
	AM-MPT-1100-9D-TM-01B	186FBE diesel engine			
2	AM-MPT-1100-9D-TM-02A	Bolt			
	AM-MPT-1100-9D-TM-02B	Bolt			
3	AM-MPT-1100-9D-TM-03A	II battery(Higher)			
	AM-MPT-1100-9D-TM-03B	III battery box			
4	AM-MPT-1100-9D-TM-04A	18Ah battery			
	AM-MPT-1100-9D-TM-04B	36Ah battery			
5	AM-MPT-1100-9D-TM-05A	+ Battery cable 18AH			
	AM-MPT-1100-9D-TM-05B	+ Battery cable 36AH			
6	AM-MPT-1100-9D-TM-06	Butterfly nut			
	AM-MPT-1100-9D-TM-07A	- Battery cable 18AH			
7	AM-MPT-1100-9D-TM-07B	- Battery cable 36AH			
8	AM-MPT-1100-9D-TM-08A	Battery press piece			
9	AM-MPT-1100-9D-TM-08B	BatterAy press piece			
10	AM-MPT-1100-9D-TM-09	Eletric start controlling cable			
11	AM-MPT-1100-9D-TM-10	Locked nut			
12	AM-MPT-1100-9D-TM-11	eletric start limit block			
13	AM-MPT-1100-9D-TM-12	Bolt			
14	AM-MPT-1100-9D-TM-13	Handle			





WARRANTY CARD

CUSTOMER COPY

DATE _____	DATE OF DELIVERY _____	DEALERS OFFICIAL SEAL	DEALERS SIGN _____
PURCHASERS NAME & ADDRESS _____ _____	 CUSTOMER SIGN		
PRODUCT NAME	PRODUCT SERIAL NO.	INVOICE/DN NO.	
			





I/Will accept the terms and conditions of warranty as in the warranty card

DEALERS COPY

DATE _____	DATE OF DELIVERY _____	DEALERS OFFICIAL SEAL	DEALERS SIGN _____
PURCHASERS NAME & ADDRESS _____ _____	 CUSTOMER SIGN		
PRODUCT NAME	PRODUCT SERIAL NO.	INVOICE/DN NO.	
			

I/Will accept the terms and conditions of warranty as in the warranty card

COMPANY COPY

DATE _____	DATE OF DELIVERY _____	DEALERS OFFICIAL SEAL	DEALERS SIGN _____
PURCHASERS NAME & ADDRESS _____ _____	 CUSTOMER SIGN		
PRODUCT NAME	PRODUCT SERIAL NO.	INVOICE/DN NO.	
			

I/Will accept the terms and conditions of warranty as in the warranty card

1. LIMITED WARRANTY PERIOD : For a period of six months from the date of Sale / delivery of the product which ever is earlier. 2. LIMITED WARRANTY OBLIGATION : Replacement of defective part(s) by authorized dealer are free of charges. If found defective by reasons of defective material / poor workmanship, parts will be replaced and there will be no value re-imburement. 3. TERMS & CONDITIONS : a. Claims under warranty will be accepted on submission of Warranty Card duly filled and stamped by authorized dealer together with the original purchase document. : b. Shipping / transportation / Incidental charges incurred in replacing defective parts under warranty shall be borne by the purchaser

WARRANTY null & void if

- (i) Lack of maintenance, (ii) Incorrect use of the machine or tampering, (iii) Use of non-genuine spare parts, (iv) Usage of acids, solvents, or any flammable materials, (v) Non-usage of filter water / clear water / soft water & using water above 40°C temperature, (vi) While using the pressure washers to draw water which is contaminated with dust & solvents (eg. paint thinners, gasoline, oil, etc.), (vii) Repair done by unauthorized service people, (viii) Those parts subject to wear & tear due to normal operations and plastic parts, rubber items etc, (ix) Loose connections, faulty electrical fixtures & fluctuations in power supply.
- 4. Should any failure occur during or after the warranty period, customer does not have the right to interrupt payment / price discount.
- 5. Incidental or consequential damages like inconvenience commercial loss, loss of tie, mental agony etc.
- 6. Loss of any nature due to operation or non-operation is not covered under warranty.
- 7. All free service are at Dealer's service point only.
- 8. Warranty ceases if service is not done periodically.
- 9. The attached card should be completed and returned to Ratnagiri Impex Pvt. Ltd. for registration immediately after sale / delivery.
- 10. The warranty is void unless you register the warranty card with Ratnagiri Impex Pvt. Ltd.
- 11. The decision of Ratnagiri Impex Pvt. Ltd., in settling the warranty is final in all respects.
- 12. All disputes are subject to Bangalore Courts Jurisdiction

1. LIMITED WARRANTY PERIOD : For a period of six months from the date of Sale / delivery of the product which ever is earlier. 2. LIMITED WARRANTY OBLIGATION : Replacement of defective part(s) by authorized dealer are free of charges. If found defective by reasons of defective material / poor workmanship, parts will be replaced and there will be no value re-imburement. 3. TERMS & CONDITIONS : a. Claims under warranty will be accepted on submission of Warranty Card duly filled and stamped by authorized dealer together with the original purchase document. : b. Shipping / transportation / Incidental charges incurred in replacing defective parts under warranty shall be borne by the purchaser.

WARRANTY null & void if

- (i) Lack of maintenance, (ii) Incorrect use of the machine or tampering, (iii) Use of non-genuine spare parts, (iv) Usage of acids, solvents, or any flammable materials, (v) Non-usage of filter water / clear water / soft water & using water above 40°C temperature, (vi) While using the pressure washers to draw water which is contaminated with dust & solvents (eg. paint thinners, gasoline, oil, etc.), (vii) Repair done by unauthorized service people, (viii) Those parts subject to wear & tear due to normal operations and plastic parts, rubber items etc, (ix) Loose connections, faulty electrical fixtures & fluctuations in power supply.
- 4. Should any failure occur during or after the warranty period, customer does not have the right to interrupt payment / price discount.
- 5. Incidental or consequential damages like inconvenience commercial loss, loss of tie, mental agony etc.
- 6. Loss of any nature due to operation or non-operation is not covered under warranty.
- 7. All free service are at Dealer's service point only.
- 8. Warranty ceases if service is not done periodically.
- 9. The attached card should be completed and returned to Ratnagiri Impex Pvt. Ltd. for registration immediately after sale / delivery.
- 10. The warranty is void unless you register the warranty card with Ratnagiri Impex Pvt. Ltd.
- 11. The decision of Ratnagiri Impex Pvt. Ltd., in settling the warranty is final in all respects.
- 12. All disputes are subject to Bangalore Courts Jurisdiction

1. LIMITED WARRANTY PERIOD : For a period of six months from the date of Sale / delivery of the product which ever is earlier. 2. LIMITED WARRANTY OBLIGATION : Replacement of defective part(s) by authorized dealer are free of charges. If found defective by reasons of defective material / poor workmanship, parts will be replaced and there will be no value re-imburement. 3. TERMS & CONDITIONS : a. Claims under warranty will be accepted on submission of Warranty Card duly filled and stamped by authorized dealer together with the original purchase document. : b. Shipping / transportation / Incidental charges incurred in replacing defective parts under warranty shall be borne by the purchaser.

WARRANTY null & void if

- (i) Lack of maintenance, (ii) Incorrect use of the machine or tampering, (iii) Use of non-genuine spare parts, (iv) Usage of acids, solvents, or any flammable materials, (v) Non-usage of filter water / clear water / soft water & using water above 40°C temperature, (vi) While using the pressure washers to draw water which is contaminated with dust & solvents (eg. paint thinners, gasoline, oil, etc.), (vii) Repair done by unauthorized service people, (viii) Those parts subject to wear & tear due to normal operations and plastic parts, rubber items etc, (ix) Loose connections, faulty electrical fixtures & fluctuations in power supply.
- 4. Should any failure occur during or after the warranty period, customer does not have the right to interrupt payment / price discount.
- 5. Incidental or consequential damages like inconvenience commercial loss, loss of tie, mental agony etc.
- 6. Loss of any nature due to operation or non-operation is not covered under warranty.
- 7. All free service are at Dealer's service point only.
- 8. Warranty ceases if service is not done periodically.
- 9. The attached card should be completed and returned to Ratnagiri Impex Pvt. Ltd. for registration immediately after sale / delivery.
- 10. The warranty is void unless you register the warranty card with Ratnagiri Impex Pvt. Ltd.
- 11. The decision of Ratnagiri Impex Pvt. Ltd., in settling the warranty is final in all respects.
- 12. All disputes are subject to Bangalore Courts Jurisdiction



FREE SERVICE COUPON (30DAYS/30HRS. WHICHEVER IS EARLIER)

MODEL	<input type="text"/>	SERIAL NUMBER	<input type="text"/>
PDI DATE	SERVICE NO.	PURCHASE BILL NO.	DATE
<input type="text"/>	<input type="text"/>	<input type="text"/>	<input type="text"/>
DEALERS OFFICE SEAL	OPERATIONS		
<input type="text"/>	<ol style="list-style-type: none"> 1. Check and test the fuel mixture 3. Check , clean and adjust the spark plug 5. Check and sparken the cutting tools 7. Start and check the noise, vibration, loosen etc.. 	<ol style="list-style-type: none"> 2. check and clean the air filter 4. Check and adjust the carburetor tuning 6. Product familirisation on usage 8. Routine maintenance and shortage. 	

FREE SERVICE COUPON (30DAYS/30HRS. WHICHEVER IS EARLIER)

MODEL	<input type="text"/>	SERIAL NUMBER	<input type="text"/>
PDI DATE	SERVICE NO.	PURCHASE BILL NO.	DATE
<input type="text"/>	<input type="text"/>	<input type="text"/>	<input type="text"/>
DEALERS OFFICE SEAL	OPERATIONS		
<input type="text"/>	<ol style="list-style-type: none"> 1. Check and test the fuel mixture 3. Check , clean and adjust the spark plug 5. Check and sparken the cutting tools 7. Start and check the noise, vibration, loosen etc.. 	<ol style="list-style-type: none"> 2. check and clean the air filter 4. Check and adjust the carburetor tuning 6. Product familirisation on usage 8. Routine maintenance and shortage. 	

FREE SERVICE COUPON (30DAYS/30HRS. WHICHEVER IS EARLIER)

MODEL	<input type="text"/>	SERIAL NUMBER	<input type="text"/>
PDI DATE	SERVICE NO.	PURCHASE BILL NO.	DATE
<input type="text"/>	<input type="text"/>	<input type="text"/>	<input type="text"/>
DEALERS OFFICE SEAL	OPERATIONS		
<input type="text"/>	<ol style="list-style-type: none"> 1. Check and test the fuel mixture 3. Check , clean and adjust the spark plug 5. Check and sparken the cutting tools 7. Start and check the noise, vibration, loosen etc.. 	<ol style="list-style-type: none"> 2. check and clean the air filter 4. Check and adjust the carburetor tuning 6. Product familirisation on usage 8. Routine maintenance and shortage. 	

DOS

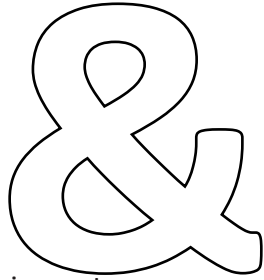

DONT'S

attempting to use the equipments.

1. Always read the instruction manual supplied along with the equipments and understand the correct installation and operating procedures before

trousers and jackets while operating potentially dangerous machines
2. It is important to use the personal protection equipments such as head helmet with visor, ear defenders, goggles, safety gloves, cut resistant shoes,
3. Avoid untrained persons using the equipments. Children must not be allowed to handle these equipments
4. Always use genuine spares and accessories in repairs and usage to derive maximum life of the equipments.
5. Always keep the equipments in good working condition to minimize loss of output as well as to reduce the pollution and save the environment
6. Do not use the machine within range of persons unless they wear protective clothing
7. Do not operate the machine when fatigued or under the influence of alcohol or drugs
8. For more query kindly contact for our Service Center/Dealer/ franchise

NO. 1 CHOICE OF FARMERS SINCE 1999



Marketed by.
**ratnagiri
impex**
BRINGING YOU THE FUTURE... NOW

RATNAGIRI IMPEX PVT., LTD.,

Annapurna House, #1 / 1G, 7th Cross, New
Guddadahalli

Mysore Road, Bangalore - 560 026

Missed Call : 7393 938 938

Email: ask@agrimart.in