

# USER MANUAL

  
**AGRIMATE**<sup>®</sup>  
Maximum Power - Super Economy

## INTERCULTIVATOR/POWER WEEDER AM-6600-9P GASOLINE ENGINE

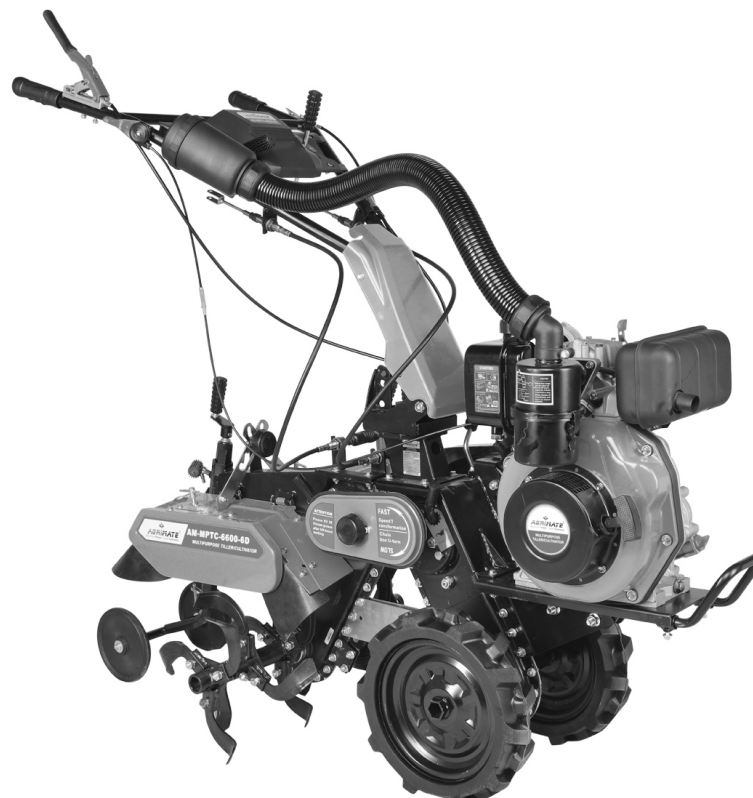

SPARE PARTS DIAGRAM & PARTLIST-AM-MPTC-6600-ENGINE

HEAD ASSAMBLEY - A

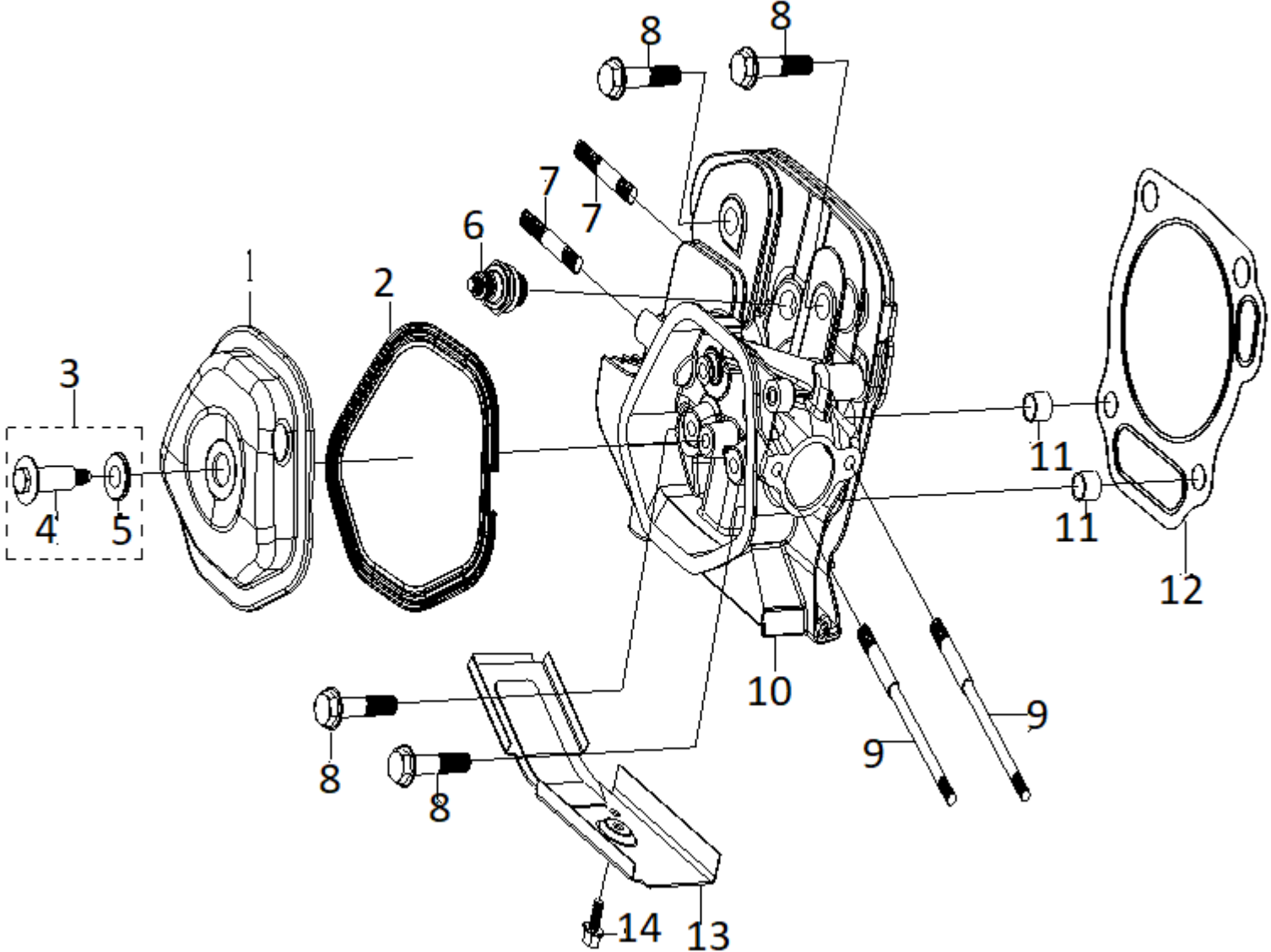

# SPARE PARTS DIAGRAM & PARTLIST-AM-MPTC-6600-ENGINE

| SL NO | PART NO      | DESCRIPTION          | SL NO | PART NO | DESCRIPTION |
|-------|--------------|----------------------|-------|---------|-------------|
| 1     | AM-177FP-A01 | HEAD COVER           |       |         |             |
| 2     | AM-177FP-A02 | GASKET HEAD COVER    |       |         |             |
| 3     | AM-177FP-A03 | BOLT COMP            |       |         |             |
| 4     | AM-177FP-A04 | BOLT COMP            |       |         |             |
| 5     | AM-177FP-A05 | WASHER,BOLT          |       |         |             |
| 6     | AM-177FP-A06 | PLUG SPARK           |       |         |             |
| 7     | AM-177FP-A07 | BOLT STUD            |       |         |             |
| 8     | AM-177FP-A08 | BOLT                 |       |         |             |
| 9     | AM-177FP-A09 | BOLT STUD            |       |         |             |
| 10    | AM-177FP-A10 | CYLINDER HEAD ASSY   |       |         |             |
| 11    | AM-177FP-A11 | PIN, DOWEL           |       |         |             |
| 12    | AM-177FP-A12 | GASKET CYLINDER HEAD |       |         |             |
| 13    | AM-177FP-A13 | WINDSHIELD           |       |         |             |
| 14    | AM-177FP-A14 | BOLT                 |       |         |             |
|       |              |                      |       |         |             |
|       |              |                      |       |         |             |

CRANKCASE ASSAMBLEY - B

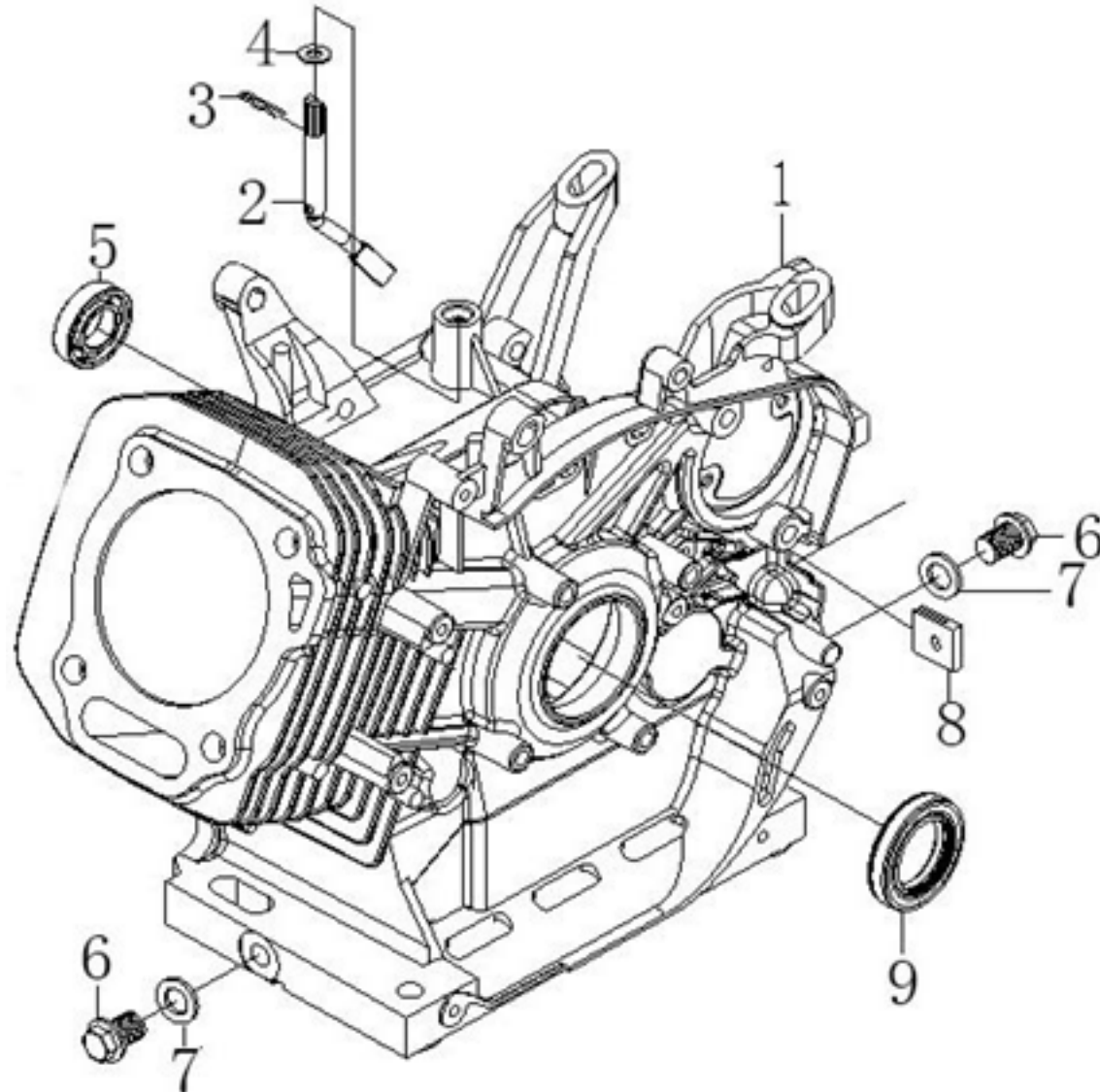



CRANK CASE COVER ASSAMBLEY - C

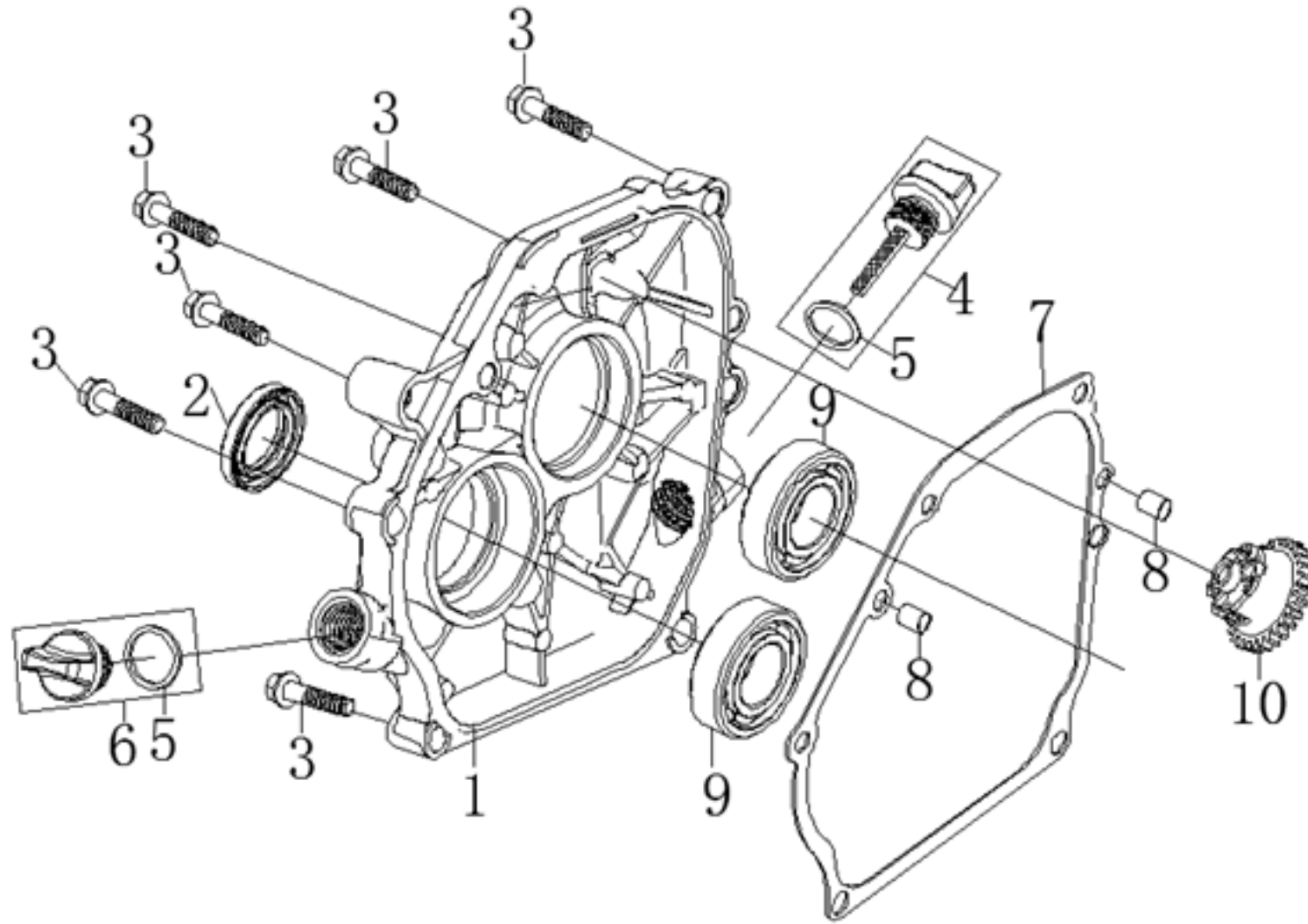

# SPARE PARTS DIAGRAM & PARTLIST-AM-MPTC-6600-ENGINE

| SL NO | PART NO      | DESCRIPTION           | SL NO | PART NO | DESCRIPTION |
|-------|--------------|-----------------------|-------|---------|-------------|
| 1     | AM-177FP-C01 | COVER, CRANKCASE      |       |         |             |
| 2     | AM-177FP-C02 | OIL SEAL              |       |         |             |
| 3     | AM-177FP-C03 | Hex Flange Bolt       |       |         |             |
| 4     | AM-177FP-C04 | DIPSTICK ASSY         |       |         |             |
| 5     | AM-177FP-C05 | DIPSTICK SEALING RING |       |         |             |
| 6     | AM-177FP-C06 | OIL FILLER PLUG ASSY  |       |         |             |
| 7     | AM-177FP-C07 | GASKET CASE COVER     |       |         |             |
| 8     | AM-177FP-C08 | PIN DOWEL             |       |         |             |
| 9     | AM-177FP-C09 | BEARING               |       |         |             |
| 10    | AM-177FP-C10 | GOVERNOR KIT COMP     |       |         |             |
|       |              |                       |       |         |             |
|       |              |                       |       |         |             |
|       |              |                       |       |         |             |
|       |              |                       |       |         |             |

# CRANK-CONNECTING ROD ASSY- D

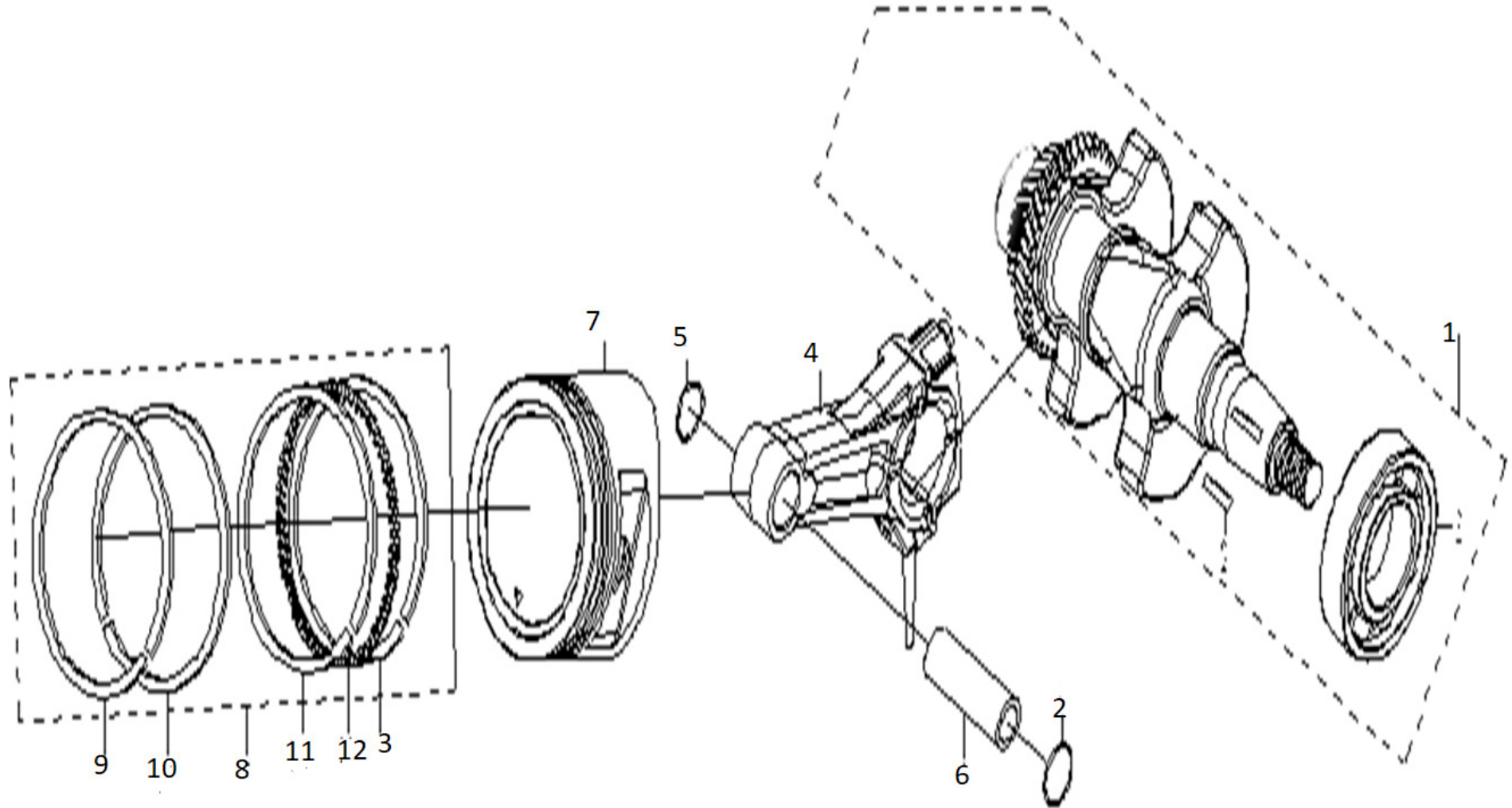



# SPARE PARTS DIAGRAM & PARTLIST-AM-MPTC-6600-ENGINE

| SL NO | PART NO      | DESCRIPTION          | SL NO | PART NO | DESCRIPTION |
|-------|--------------|----------------------|-------|---------|-------------|
| 1     | AM-177FP-D01 | CRANK SHAFT ASSY     |       |         |             |
| 2     | AM-177FP-D02 | SPECIAL WOODRUFF KEY |       |         |             |
| 3     | AM-177FP-D03 | BEARING              |       |         |             |
| 4     | AM-177FP-D04 | CONNECTING ROD ASSY  |       |         |             |
| 5     | AM-177FP-D05 | CLIP-PISTON PIN      |       |         |             |
| 6     | AM-177FP-D06 | PIN-PISTON           |       |         |             |
| 7     | AM-177FP-D07 | PISTON               |       |         |             |
| 8     | AM-177FP-D08 | PISTON RING ASSY     |       |         |             |
| 9     | AM-177FP-D09 | GAS RING ONE         |       |         |             |
| 10    | AM-177FP-D10 | GAS RING TWO         |       |         |             |
| 11    | AM-177FP-D11 | FILM LOOP            |       |         |             |
| 12    | AM-177FP-D12 | BUSH RING            |       |         |             |
|       |              |                      |       |         |             |
|       |              |                      |       |         |             |
|       |              |                      |       |         |             |
|       |              |                      |       |         |             |

# SPARE PARTS DIAGRAM & PARTLIST-AM-MPTC-6600-ENGINE

## VALVE TRAIN ASSY - E

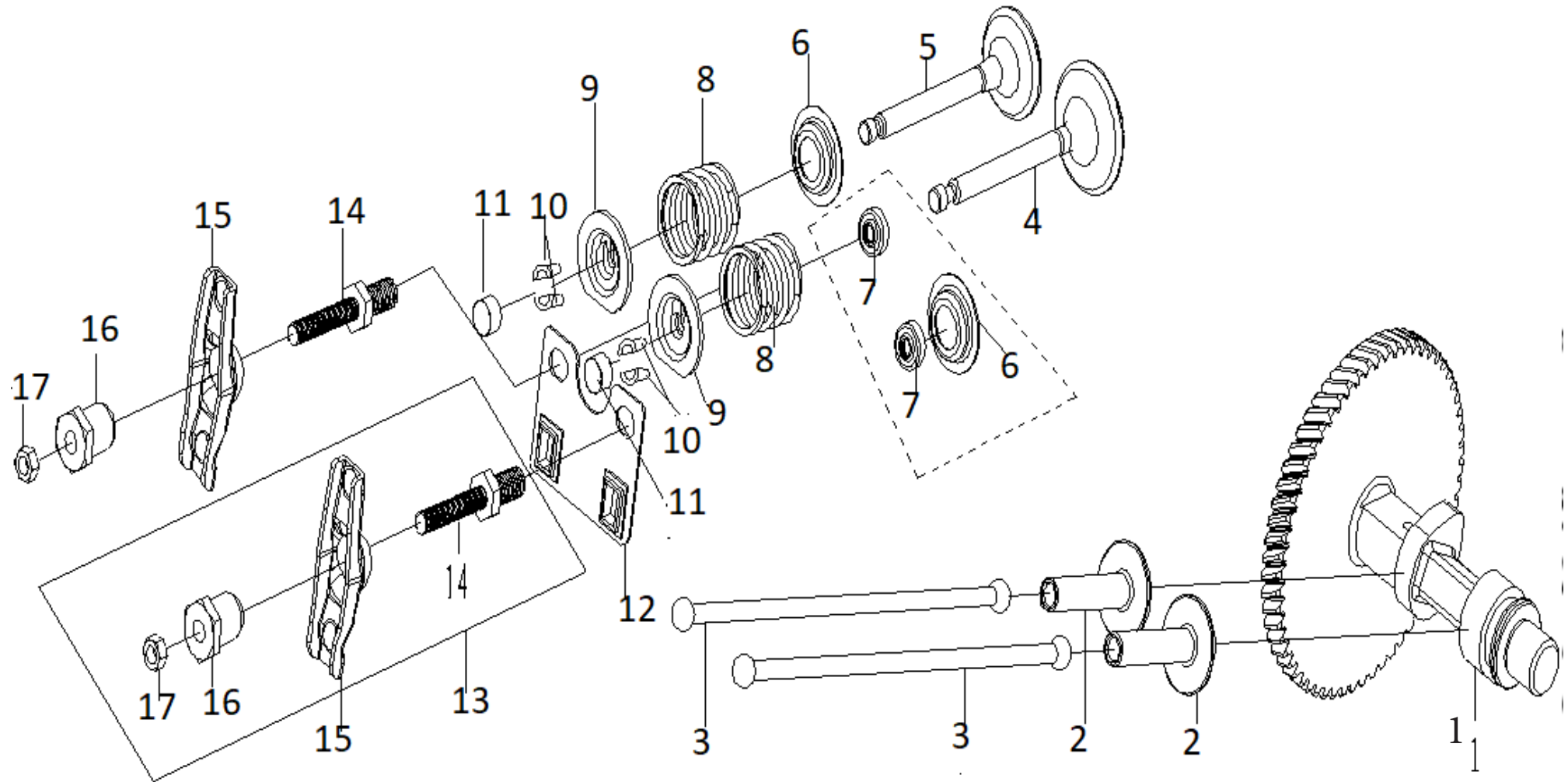

# SPARE PARTS DIAGRAM & PARTLIST-AM-MPTC-6600-ENGINE

| SL NO | PART NO      | DESCRIPTION               | SL NO | PART NO      | DESCRIPTION      |
|-------|--------------|---------------------------|-------|--------------|------------------|
| 1     | AM-177FP-E01 | CAMSHAFT ASSY             | 17    | AM-177FP-E17 | NUTPIVOT LOCKING |
| 2     | AM-177FP-E02 | LIFTER VALVE              |       |              |                  |
| 3     | AM-177FP-E03 | ROD PUSH                  |       |              |                  |
| 4     | AM-177FP-E04 | VALVE INLET               |       |              |                  |
| 5     | AM-177FP-E05 | VALVE EXHAUST             |       |              |                  |
| 6     | AM-177FP-E06 | VALVE SPRING SEAT         |       |              |                  |
| 7     | AM-177FP-E07 | VALVE SEAL                |       |              |                  |
| 8     | AM-177FP-E08 | SPRING VALVE              |       |              |                  |
| 9     | AM-177FP-E09 | OUTTAKE VALVE SPRING SEAT |       |              |                  |
| 10    | AM-177FP-E10 | NA                        |       |              |                  |
| 11    | AM-177FP-E11 | ADJUSTER EX. VALVE        |       |              |                  |
| 12    | AM-177FP-E12 | PLATE PUSH ROD GUIDE      |       |              |                  |
| 13    | AM-177FP-E13 | ARM ASSY VALVE ROCKER     |       |              |                  |
| 14    | AM-177FP-E14 | BOLT PIVOT                |       |              |                  |
| 15    | AM-177FP-E15 | ARM VALVE ROCKER          |       |              |                  |
| 16    | AM-177FP-E16 | ADJUSTING NUT VALVE       |       |              |                  |

# SPARE PARTS DIAGRAM & PARTLIST-AM-MPTC-6600-ENGINE

## STAR ASSY - F

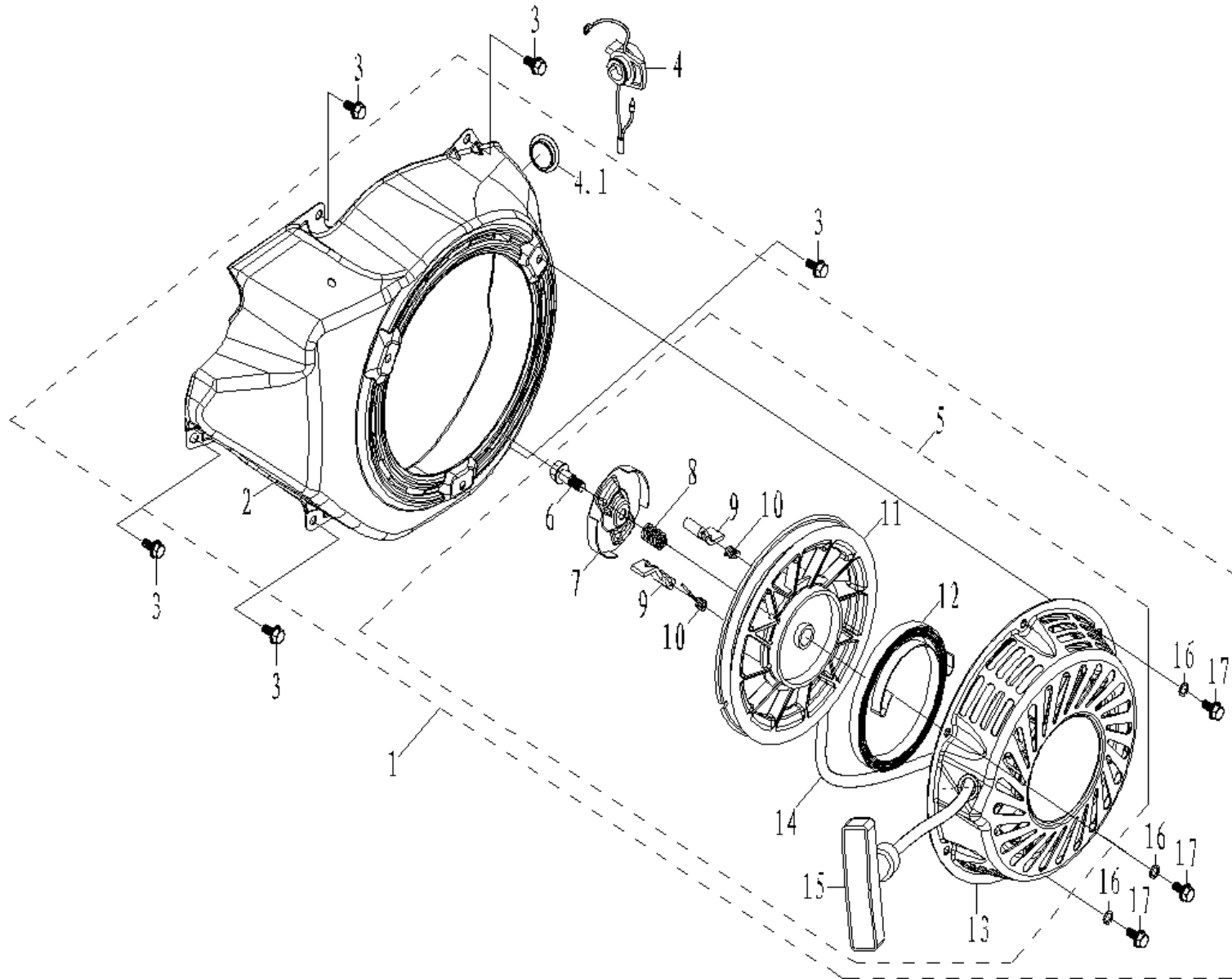

# SPARE PARTS DIAGRAM & PARTLIST-AM-MPTC-6600-ENGINE

| SL NO | PART NO       | DESCRIPTION               | SL NO | PART NO      | DESCRIPTION |
|-------|---------------|---------------------------|-------|--------------|-------------|
| 1     | AM-177FP-F01  | RECOIL STARTER ASSY       | 17    | AM-177FP-F17 | BOLT        |
| 2     | AM-177FP-F02  | WIND SCOOPER              |       |              |             |
| 3     | AM-177FP-F03  | BOLT                      |       |              |             |
| 4     | AM-177FP-F04  | SWITH ASSY,ENGINE STOP    |       |              |             |
| 4.1   | AM-177FP-F4.1 | PLUG,RECOIL STARTER       |       |              |             |
| 5     | AM-177FP-F05  | STARTER COMP RECOIL       |       |              |             |
| 6     | AM-177FP-F06  | CENTER POSITION BOLT      |       |              |             |
| 7     | AM-177FP-F07  | RATCHET GUIDE             |       |              |             |
| 8     | AM-177FP-F08  | CENTER POSITION SPRING    |       |              |             |
| 9     | AM-177FP-F09  | RATCHET STARTER           |       |              |             |
| 10    | AM-177FP-F10  | SPRING RETURN             |       |              |             |
| 11    | AM-177FP-F11  | REEL RECOIL STARTER       |       |              |             |
| 12    | AM-177FP-F12  | SPRING STARTER RETURN     |       |              |             |
| 13    | AM-177FP-F13  | STARTER COVER COMP RECOIL |       |              |             |
| 14    | AM-177FP-F14  | ROPE RECOIL STARTER       |       |              |             |
| 15    | AM-177FP-F15  | HANDLE STARTER            |       |              |             |
| 16    | AM-177FP-F16  | Wire Clamp                |       |              |             |

# SPARE PARTS DIAGRAM & PARTLIST-AM-MPTC-6600-ENGINE

## INLET ASSY - G

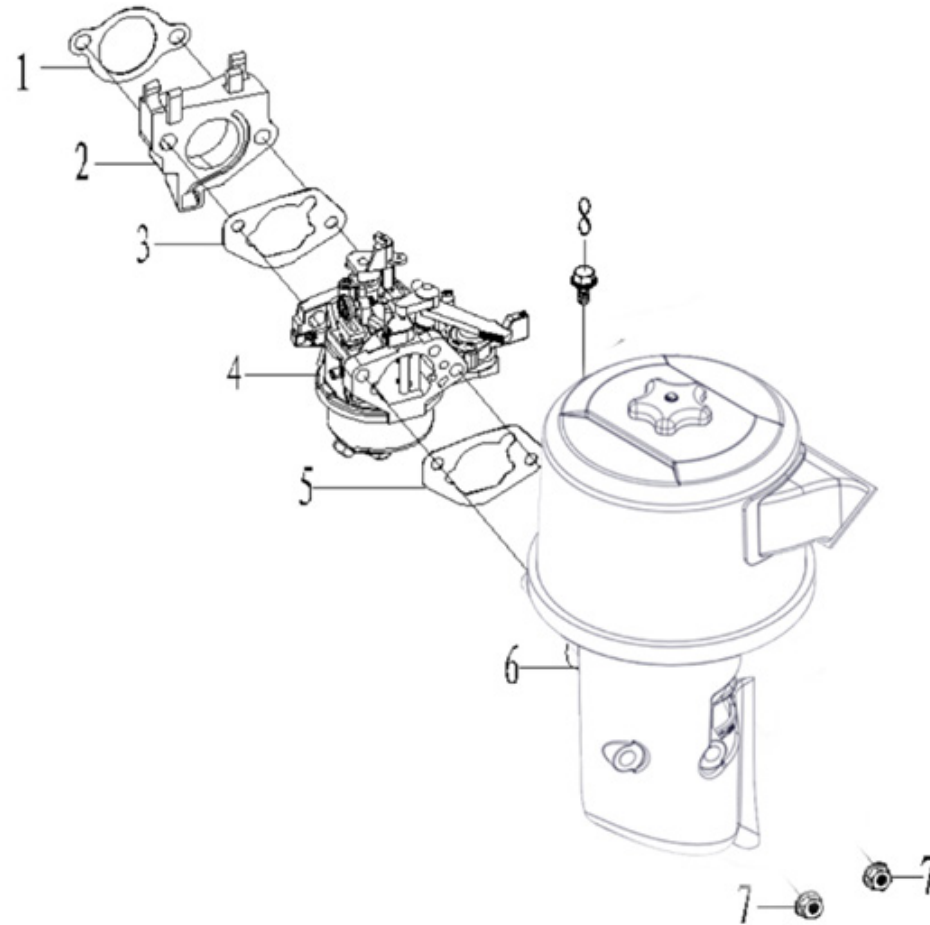



AIR FILTER ASSY - H

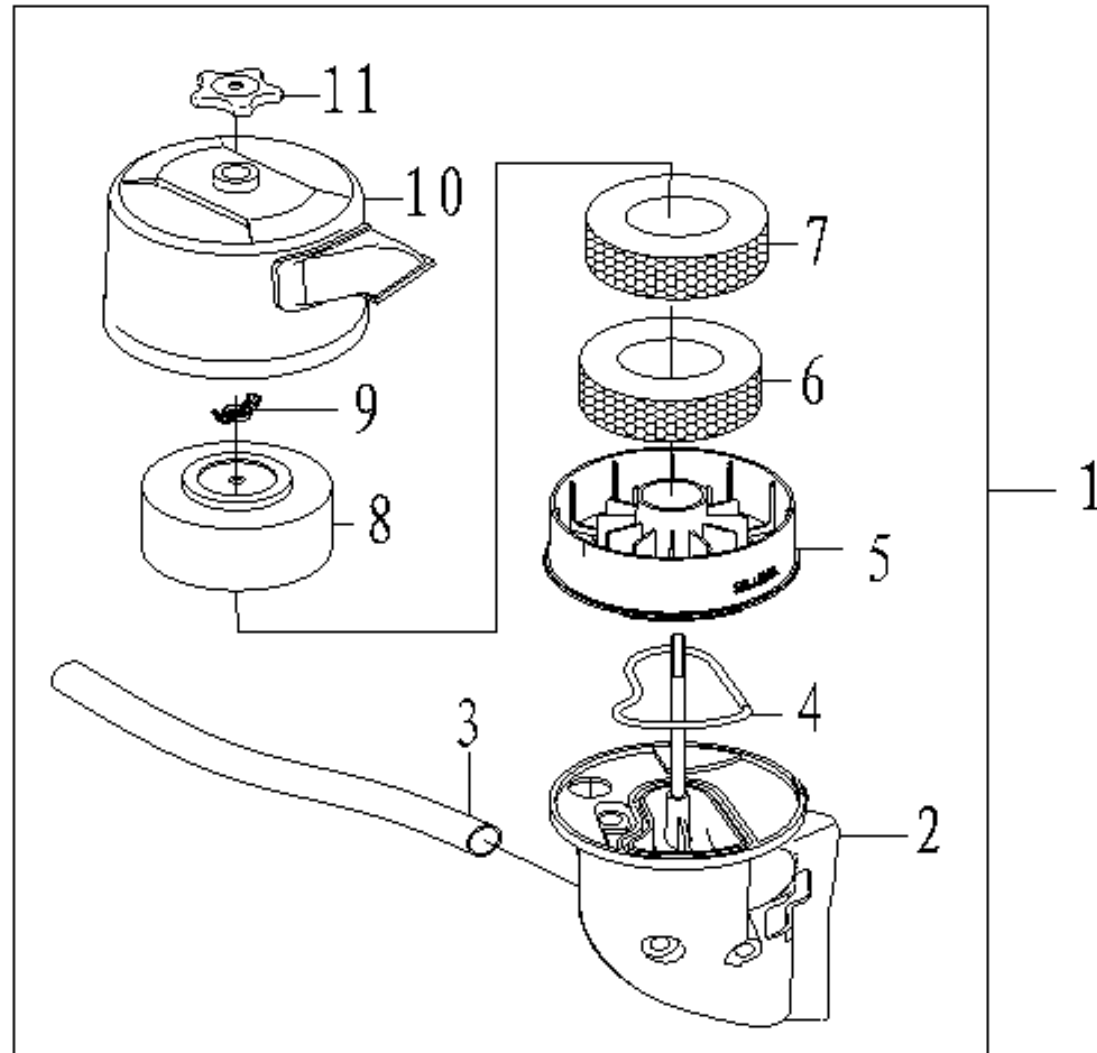





# SPARE PARTS DIAGRAM & PARTLIST-AM-MPTC-6600-ENGINE

## CARBURETOR CIRCUIT ASSY - J

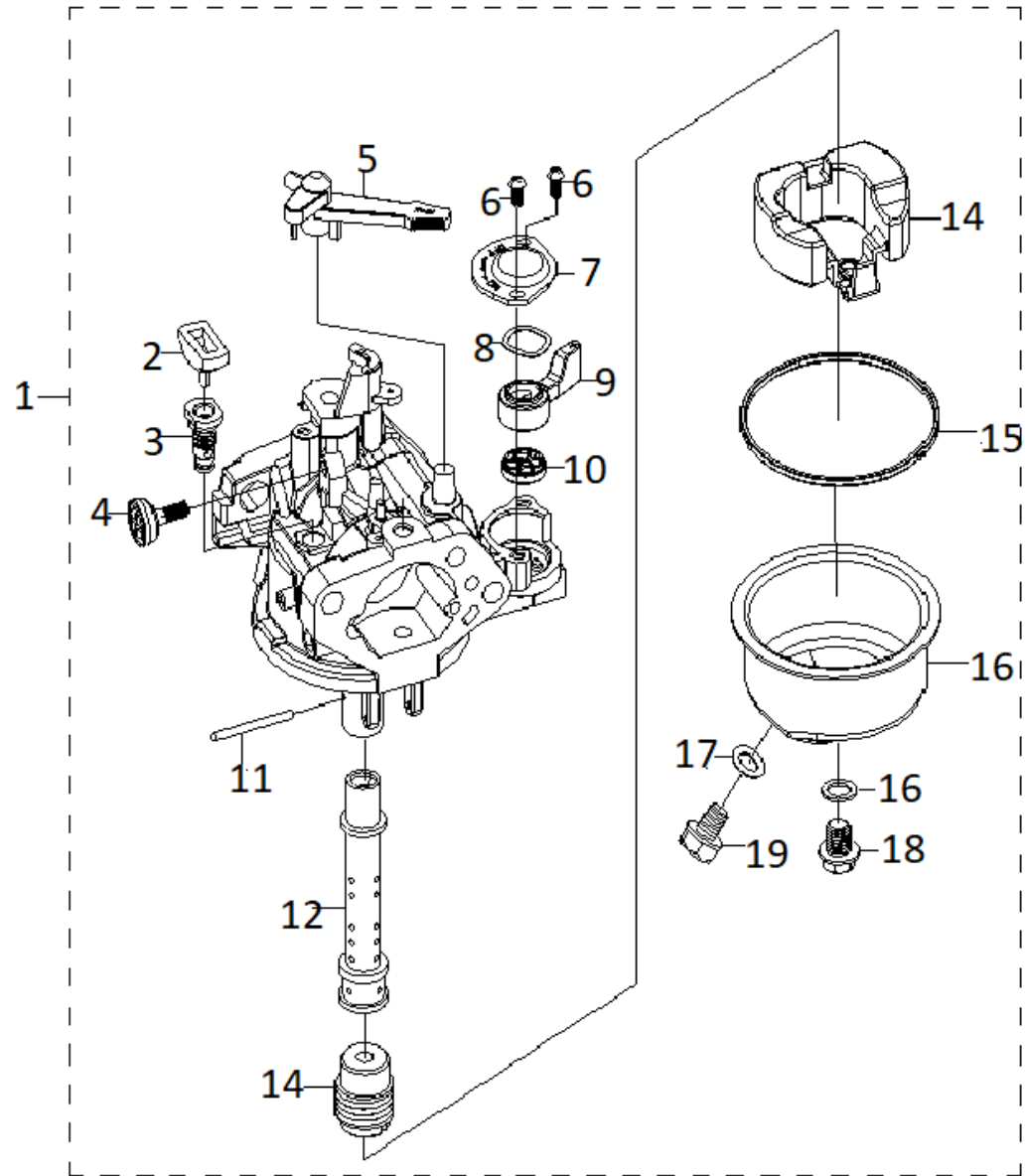

# SPARE PARTS DIAGRAM & PARTLIST-AM-MPTC-6600-ENGINE

| SL NO | PART NO      | DESCRIPTION             | SL NO | PART NO      | DESCRIPTION     |
|-------|--------------|-------------------------|-------|--------------|-----------------|
| 1     | AM-177FP-J01 | CARBURETOR              | 17    | AM-177FP-J17 | GASKET          |
| 2     | AM-177FP-J02 | CAP,IDLE HOLE           | 18    | AM-177FP-J18 | BOLT            |
| 3     | AM-177FP-J03 | IDLE HOLE COMPONENT     | 19    | AM-177FP-J19 | BOLT&DRAIN PLUG |
| 4     | AM-177FP-J04 | JET SET PILOT           |       |              |                 |
| 5     | AM-177FP-J05 | CHOKE PLATE HANDLE      |       |              |                 |
| 6     | AM-177FP-J06 | SCREW                   |       |              |                 |
| 7     | AM-177FP-J07 | FUEL SWITCH COVER PLATE |       |              |                 |
| 8     | AM-177FP-J08 | WASHER                  |       |              |                 |
| 9     | AM-177FP-J09 | FUEL SWITCH HANDLE      |       |              |                 |
| 10    | AM-177FP-J10 | FUEL SWITCH SEAL        |       |              |                 |
| 11    | AM-177FP-J11 | PIN                     |       |              |                 |
| 12    | AM-177FP-J12 | NOZZLE MAIN             |       |              |                 |
| 13    | AM-177FP-J13 | JET MAIN                |       |              |                 |
| 14    | AM-177FP-J14 | FLOAT SET               |       |              |                 |
| 15    | AM-177FP-J15 | CHAMBER SET,FLOAT       |       |              |                 |
| 16    | AM-177FP-J16 | WASHER                  |       |              |                 |

THROTTLE CONTROL ASSY - K

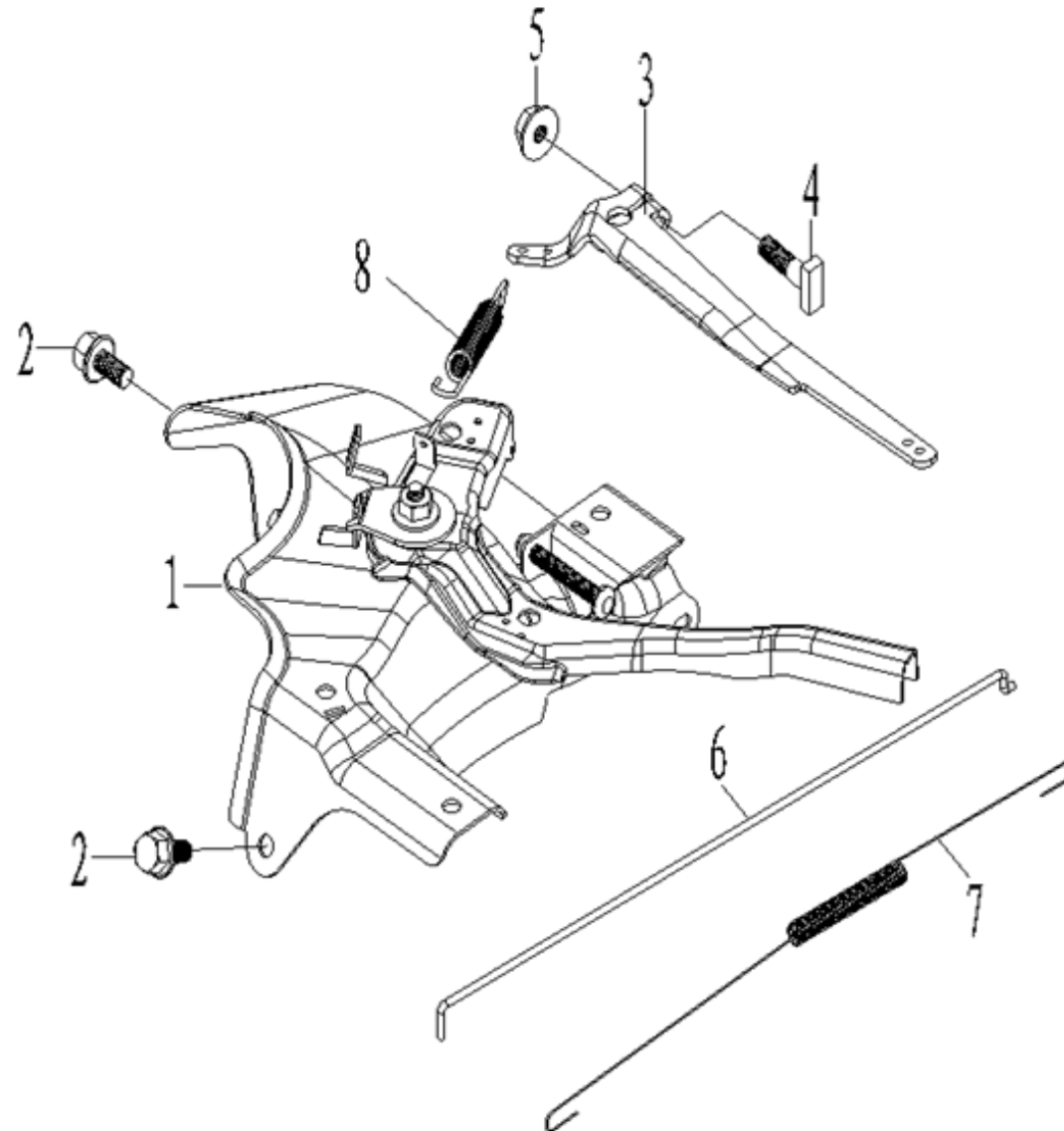



FLYWHEEL AND IGNITION ASSY - L

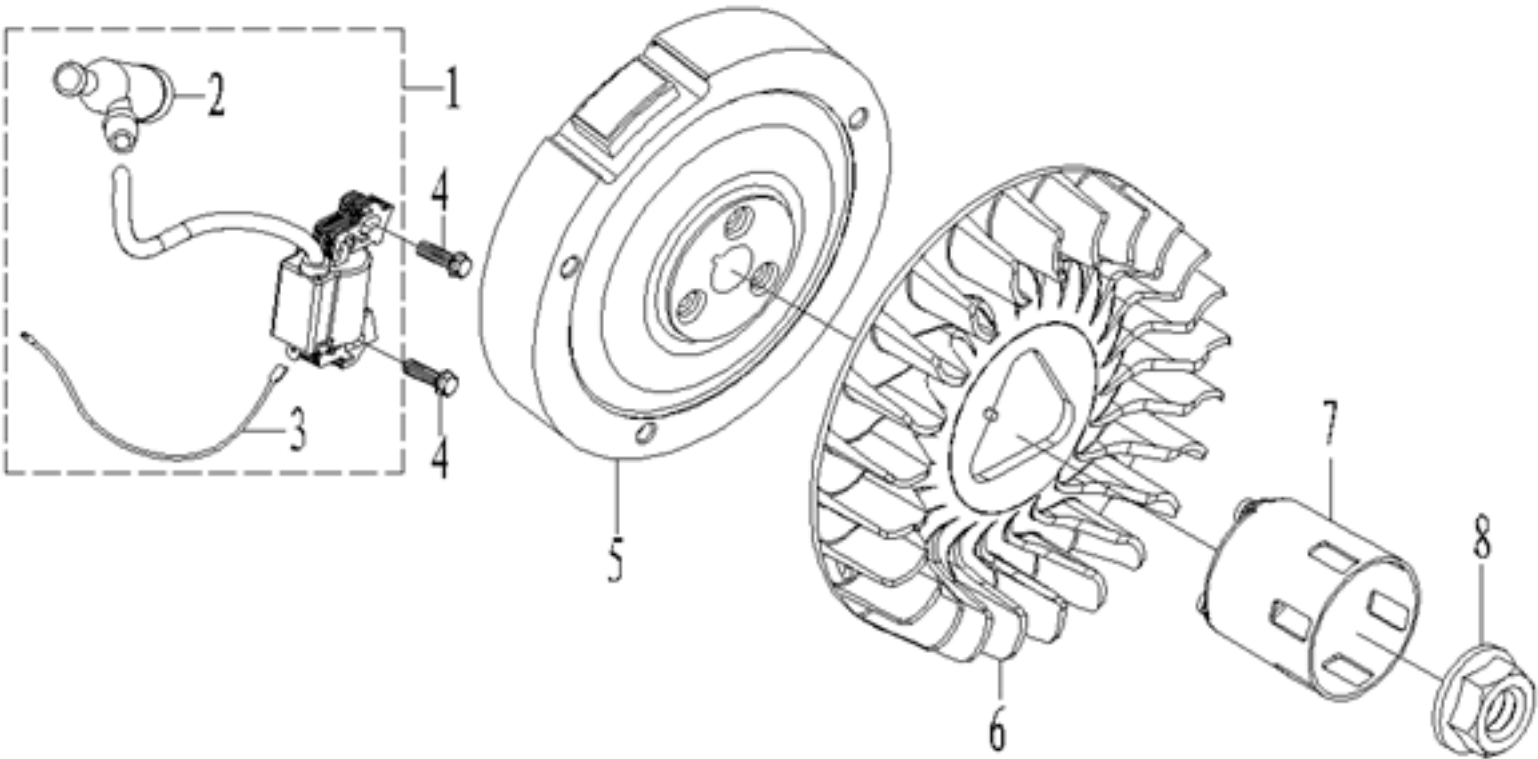



# SPARE PARTS DIAGRAM & PARTLIST-AM-MPTC-6600-ENGINE

## EXHAUST ASSY - M

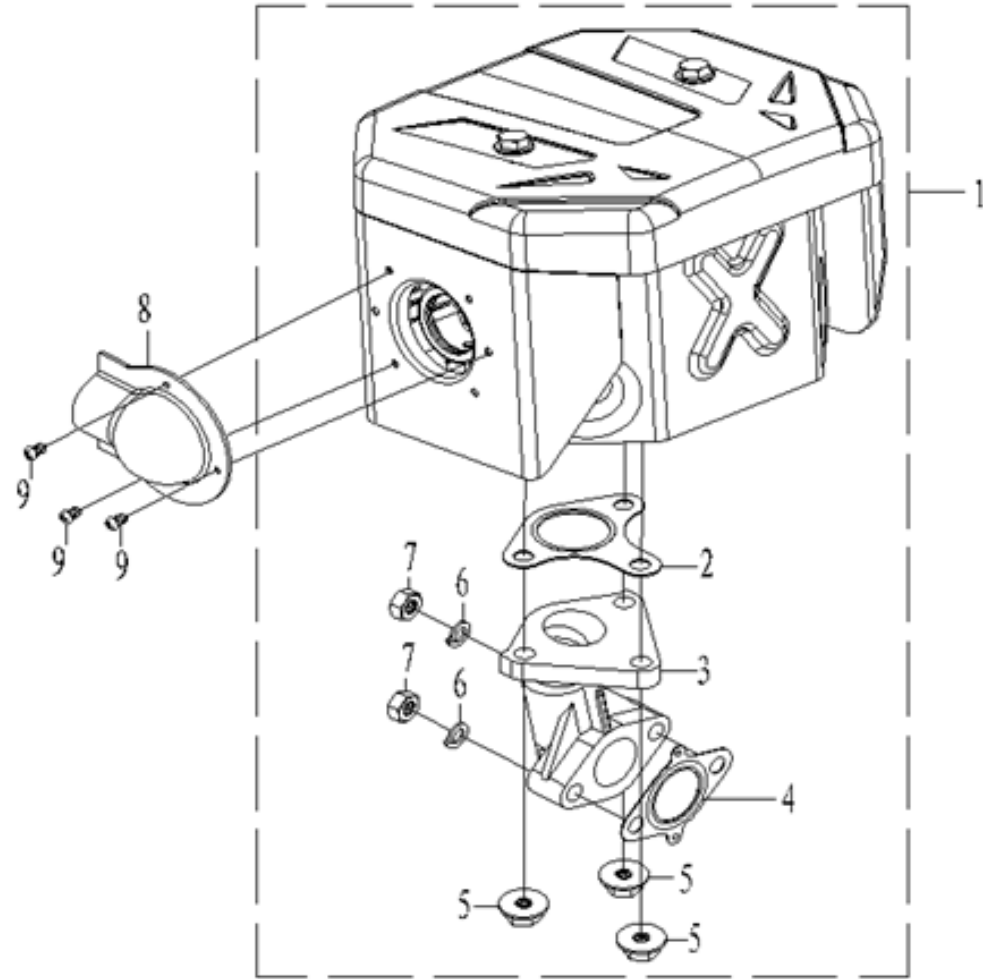





# SPARE PARTS DIAGRAM & PARTLIST-AM-MPTC-6600-ENGINE

## FULE OIL ASSY - N

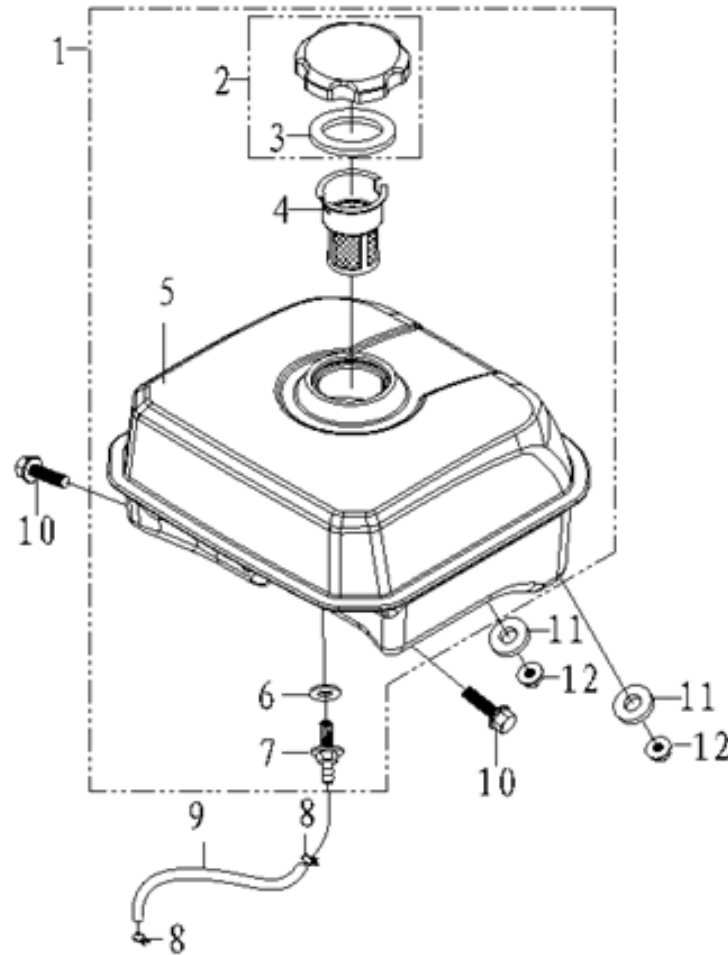

## SPARE PARTS DIAGRAM & PARTLIST-AM-MPTC-6600-ENGINE

| SL NO | PART NO      | DESCRIPTION             | SL NO | PART NO | DESCRIPTION |
|-------|--------------|-------------------------|-------|---------|-------------|
| 1     | AM-177FP-N01 | TANK FUEL COMP.         |       |         |             |
| 2     | AM-177FP-N02 | CAP COMP,FUEL FILLER    |       |         |             |
| 3     | AM-177FP-N03 | PACKING,FUEL FILLER     |       |         |             |
| 4     | AM-177FP-N04 | FILTER FUEL             |       |         |             |
| 5     | AM-177FP-N05 | FUEL TANK               |       |         |             |
| 6     | AM-177FP-N06 | PACKING                 |       |         |             |
| 7     | AM-177FP-N07 | JOINT,FUEL TANK         |       |         |             |
| 8     | AM-177FP-N08 | CLIP,TUBE               |       |         |             |
| 9     | AM-177FP-N09 | TUBE,FUEL               |       |         |             |
| 10    | AM-177FP-N10 | BOLT                    |       |         |             |
| 11    | AM-177FP-N11 | WASHER,                 |       |         |             |
| 12    | AM-177FP-N12 | NUT                     |       |         |             |
| 13    | AM-177FP-N13 | Fuel tank rubber gasket |       |         |             |
| 14    | AM-177FP-N14 | Wire clamp              |       |         |             |
|       |              |                         |       |         |             |
|       |              |                         |       |         |             |

## INSPECTION & MAINTAINANCE

For safety use, make sure the machine is cleaned every three months. Before working, make sure to inspect the filter and the nozzle and ensure there is no impurity. After working, make sure there is no water in the pump and the hose.

If the machine needs to be repaired in the guarantee period, please return the machine to the shop. You need to provide the certificate of purchase on order to repair or get the substitute.

Before packing, the machine should be cleaned, then use closed packaging, packaging should be firm. Store the machine in dry place.

For transportation safety. The machine should comply with ISTA.





Do not dispose of electrical machines as unsorted municipal waste, use separate collection facilities.

If electrical machines are disposed of in landfills or dumps, hazardous substances can leak into the ground water and get into the food chain, damaging your health and well being.

When replacing old machines with new ones, the retailer is legally obligated to take back your old machine for disposals at least free of charge.





# WARRANTY CARD

## CUSTOMER COPY

|   |   |   |                    |
|---|---|---|--------------------|
| DATE _____  | DATE OF DELIVERY _____  | DEALERS OFFICIAL SEAL   | DEALERS SIGN _____ |
| PURCHASERS NAME & ADDRESS _____<br>_____  | <br>CUSTOMER SIGN |  |                    |
| PRODUCT NAME  | PRODUCT SERIAL NO.  | INVOICE/DN NO.  |                    |
|  |                   |  |                    |

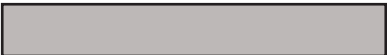



I/Will accept the terms and conditions of warranty as in the warranty card

## DEALERS COPY

|   |   |   |                    |
|---|---|---|--------------------|
| DATE _____  | DATE OF DELIVERY _____  | DEALERS OFFICIAL SEAL   | DEALERS SIGN _____ |
| PURCHASERS NAME & ADDRESS _____<br>_____  | <br>CUSTOMER SIGN |  |                    |
| PRODUCT NAME  | PRODUCT SERIAL NO.  | INVOICE/DN NO.  |                    |
|  |                   |  |                    |

I/Will accept the terms and conditions of warranty as in the warranty card

## COMPANY COPY

|   |   |   |                    |
|---|---|---|--------------------|
| DATE _____  | DATE OF DELIVERY _____  | DEALERS OFFICIAL SEAL   | DEALERS SIGN _____ |
| PURCHASERS NAME & ADDRESS _____<br>_____  | <br>CUSTOMER SIGN |  |                    |
| PRODUCT NAME  | PRODUCT SERIAL NO.  | INVOICE/DN NO.  |                    |
|  |                   |  |                    |

I/Will accept the terms and conditions of warranty as in the warranty card

1. LIMITED WARRANTY PERIOD : For a period of six months from the date of Sale / delivery of the product which ever is earlier. 2. LIMITED WARRANTY OBLIGATION : Replacement of defective part(s) by authorized dealer are free of charges. If found defective by reasons of defective material / poor workmanship, parts will be replaced and there will be no value re-imburement. 3. TERMS & CONDITIONS : a. Claims under warranty will be accepted on submission of Warranty Card duly filled and stamped by authorized dealer together with the original purchase document. : b. Shipping / transportation / Incidental charges incurred in replacing defective parts under warranty shall be borne by the purchaser

WARRANTY null & void if

- (i) Lack of maintenance, (ii) Incorrect use of the machine or tampering, (iii) Use of non-genuine spare parts, (iv) Usage of acids, solvents, or any flammable materials, (v) Non-usage of filter water / clear water / soft water & using water above 40°C temperature, (vi) While using the pressure washers to draw water which is contaminated with dust & solvents (eg. paint thinners, gasoline, oil, etc.), (vii) Repair done by unauthorized service people, (viii) Those parts subject to wear & tear due to normal operations and plastic parts, rubber items etc, (ix) Loose connections, faulty electrical fixtures & fluctuations in power supply.
- 4. Should any failure occur during or after the warranty period, customer does not have the right to interrupt payment / price discount.
- 5. Incidental or consequential damages like inconvenience commercial loss, loss of tie, mental agony etc.
- 6. Loss of any nature due to operation or non-operation is not covered under warranty.
- 7. All free service are at Dealer's service point only.
- 8. Warranty ceases if service is not done periodically.
- 9. The attached card should be completed and returned to Ratnagiri Impex Pvt. Ltd. for registration immediately after sale / delivery.
- 10. The warranty is void unless you register the warranty card with Ratnagiri Impex Pvt. Ltd.
- 11. The decision of Ratnagiri Impex Pvt. Ltd., in settling the warranty is final in all respects.
- 12. All disputes are subject to Bangalore Courts Jurisdiction

1. LIMITED WARRANTY PERIOD : For a period of six months from the date of Sale / delivery of the product which ever is earlier. 2. LIMITED WARRANTY OBLIGATION : Replacement of defective part(s) by authorized dealer are free of charges. If found defective by reasons of defective material / poor workmanship, parts will be replaced and there will be no value re-imburement. 3. TERMS & CONDITIONS : a. Claims under warranty will be accepted on submission of Warranty Card duly filled and stamped by authorized dealer together with the original purchase document. : b. Shipping / transportation / Incidental charges incurred in replacing defective parts under warranty shall be borne by the purchaser.

WARRANTY null & void if

- (i) Lack of maintenance, (ii) Incorrect use of the machine or tampering, (iii) Use of non-genuine spare parts, (iv) Usage of acids, solvents, or any flammable materials, (v) Non-usage of filter water / clear water / soft water & using water above 40°C temperature, (vi) While using the pressure washers to draw water which is contaminated with dust & solvents (eg. paint thinners, gasoline, oil, etc.), (vii) Repair done by unauthorized service people, (viii) Those parts subject to wear & tear due to normal operations and plastic parts, rubber items etc, (ix) Loose connections, faulty electrical fixtures & fluctuations in power supply.
- 4. Should any failure occur during or after the warranty period, customer does not have the right to interrupt payment / price discount.
- 5. Incidental or consequential damages like inconvenience commercial loss, loss of tie, mental agony etc.
- 6. Loss of any nature due to operation or non-operation is not covered under warranty.
- 7. All free service are at Dealer's service point only.
- 8. Warranty ceases if service is not done periodically.
- 9. The attached card should be completed and returned to Ratnagiri Impex Pvt. Ltd. for registration immediately after sale / delivery.
- 10. The warranty is void unless you register the warranty card with Ratnagiri Impex Pvt. Ltd.
- 11. The decision of Ratnagiri Impex Pvt. Ltd., in settling the warranty is final in all respects.
- 12. All disputes are subject to Bangalore Courts Jurisdiction

1. LIMITED WARRANTY PERIOD : For a period of six months from the date of Sale / delivery of the product which ever is earlier. 2. LIMITED WARRANTY OBLIGATION : Replacement of defective part(s) by authorized dealer are free of charges. If found defective by reasons of defective material / poor workmanship, parts will be replaced and there will be no value re-imburement. 3. TERMS & CONDITIONS : a. Claims under warranty will be accepted on submission of Warranty Card duly filled and stamped by authorized dealer together with the original purchase document. : b. Shipping / transportation / Incidental charges incurred in replacing defective parts under warranty shall be borne by the purchaser.

WARRANTY null & void if

- (i) Lack of maintenance, (ii) Incorrect use of the machine or tampering, (iii) Use of non-genuine spare parts, (iv) Usage of acids, solvents, or any flammable materials, (v) Non-usage of filter water / clear water / soft water & using water above 40°C temperature, (vi) While using the pressure washers to draw water which is contaminated with dust & solvents (eg. paint thinners, gasoline, oil, etc.), (vii) Repair done by unauthorized service people, (viii) Those parts subject to wear & tear due to normal operations and plastic parts, rubber items etc, (ix) Loose connections, faulty electrical fixtures & fluctuations in power supply.
- 4. Should any failure occur during or after the warranty period, customer does not have the right to interrupt payment / price discount.
- 5. Incidental or consequential damages like inconvenience commercial loss, loss of tie, mental agony etc.
- 6. Loss of any nature due to operation or non-operation is not covered under warranty.
- 7. All free service are at Dealer's service point only.
- 8. Warranty ceases if service is not done periodically.
- 9. The attached card should be completed and returned to Ratnagiri Impex Pvt. Ltd. for registration immediately after sale / delivery.
- 10. The warranty is void unless you register the warranty card with Ratnagiri Impex Pvt. Ltd.
- 11. The decision of Ratnagiri Impex Pvt. Ltd., in settling the warranty is final in all respects.
- 12. All disputes are subject to Bangalore Courts Jurisdiction



**FREE SERVICE COUPON (30DAYS/30HRS. WHICHEVER IS EARLIER)**

MODEL

SERIAL NUMBER

PDI DATE

SERVICE NO.

PURCHASE BILL NO.

DATE

DEALERS OFFICE SEAL

- 1. Check and test the fuel mixture
- 3. Check , clean and adjust the spark plug
- 5. Check and sparken the cutting tools
- 7. Start and check the noise, vibration, loosen etc..

OPERATIONS

- 2. check and clean the air filter
- 4. Check and adjust the carburetor tuning
- 6. Product familirisation on usage
- 8. Routine maintenance and shortage.

**FREE SERVICE COUPON (30DAYS/30HRS. WHICHEVER IS EARLIER)**

MODEL

SERIAL NUMBER

PDI DATE

SERVICE NO.

PURCHASE BILL NO.

DATE

DEALERS OFFICE SEAL

- 1. Check and test the fuel mixture
- 3. Check , clean and adjust the spark plug
- 5. Check and sparken the cutting tools
- 7. Start and check the noise, vibration, loosen etc..

OPERATIONS

- 2. check and clean the air filter
- 4. Check and adjust the carburetor tuning
- 6. Product familirisation on usage
- 8. Routine maintenance and shortage.

**FREE SERVICE COUPON (30DAYS/30HRS. WHICHEVER IS EARLIER)**

MODEL

SERIAL NUMBER

PDI DATE

SERVICE NO.

PURCHASE BILL NO.

DATE

DEALERS OFFICE SEAL

- 1. Check and test the fuel mixture
- 3. Check , clean and adjust the spark plug
- 5. Check and sparken the cutting tools
- 7. Start and check the noise, vibration, loosen etc..

OPERATIONS

- 2. check and clean the air filter
- 4. Check and adjust the carburetor tuning
- 6. Product familirisation on usage
- 8. Routine maintenance and shortage.

# DOS

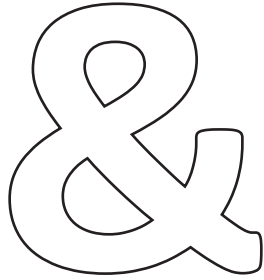

# DONT'S

1. Always read the instruction manual supplied along with the equipments and understand the correct installation and operating procedures before attempting to use the equipments.
2. It is important to use the personal protection equipments such as head helmet with visor, ear defenders, goggles, safety gloves, cut resistant shoes, trousers and jackets while operating potentially dangerous machines
3. Avoid untrained persons using the equipments. Children must not be allowed to handle these equipments
4. Always use genuine spares and accessories in repairs and usage to derive maximum life of the equipments.
5. Always keep the equipments in good working condition to minimize loss of output as well as to reduce the pollution and save the environment
6. Do not use the machine within range of persons unless they wear protective clothing
7. Do not operate the machine when fatigued or under the influence of alcohol or drugs
8. When the machine is running, please maintain a constant water supply. Without water circulation will damage the sealing rings of the machine.
9. For more query kindly contact for our Service Center/Dealer/ franchise



# Agrimate Army For Pest Control

ANY WHERE - ANY TIME - ANY CROP

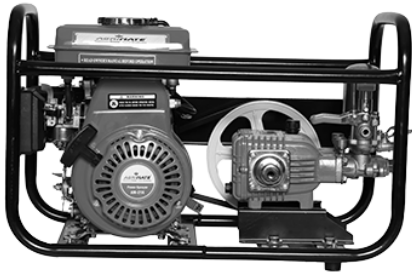
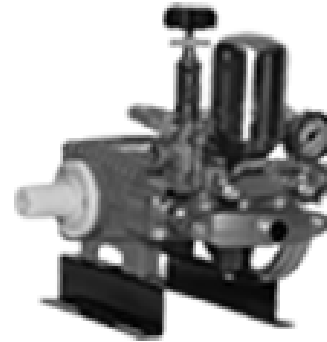

Marketed by:  
**ratnagiri  
impex**  
BRINGING YOU THE FUTURE... NOW

IMPORTED & MARKETING BY,  
**RATNAGIRI IMPEX PVT., LTD.,**

Annapurna House, #1 / 1G, 7th Cross, New  
Guddadahalli Mysore Road, Bangalore - 560 026

Missed Call : 7393 938 938 Email: [ask@agrimart.in](mailto:ask@agrimart.in)