

INTERCULTIVATOR / POWER WEEDER



AM-RT-212

TRANSMISSION DIAGRAM WITH PART LIST

7P 7P-WL 7P-WL-MAX 7P-WL-ES 7P-WL-MAX



Precautions

- When starting the machine, set shifting bar to the neutral position.
- When the machine is working, pay attention to the safety!
- Be careful not to be hurt by the rotary blades!
- When grasp the reverse handle, the shifting bar must be set to the neutral position.
- Fuel and lubricant must be clean.
- Clutch must be broken off when changing the shift.
- Please read the contents of nameplate on the handle bar carefully before using the machine.
- Must install the safety protecting board on the machine before using machine or after maintenance.

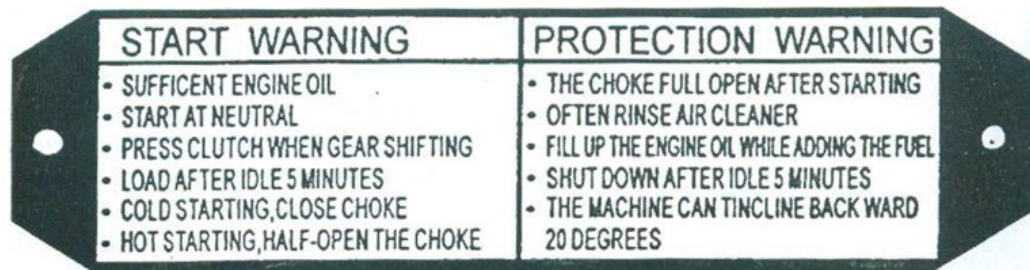

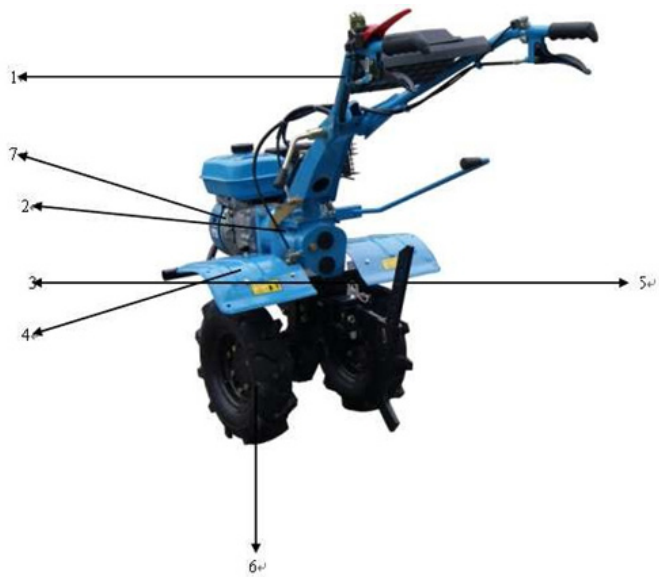

- 1 . Handle Bar
- 2 . Gear-box Assy.
- 3 . Adjustment Screw
- 4 . Fender
- 5 . Deep Furrowing Resistance Stick
- 6 . Stepped Box Assy.



- 7 . Diesel Engine
- 8 . Bumper
- 9 . Throttle Switch
- 10 . Shifting Bar

Cultivating

Fix the cultivating device onto the left and right side of the transmission shaft of the running part of the power tiller, then use two M8×55 screw bolts for axial positioning. After that, the machine can start cultivating finally.

Form of cultivating devices	Four groups	
	3 blades	4 blades
No. of rotary blades	3×8	4×8
Width of cultivating (mm)	1000	1000
Applicable earth	Paddy filed without enough water and with Earth of high viscosity	Hard earth

Ditching & Ridging

Knock down the adjustment screw before the ditcher is fixed. Subject to the adjustment of the width and height for ditcher, then the ditching can be conducted.

Short Distance Transport

when fixing the forearm of the wagon box on the trailer and wheels on the transmission shaft of the running part, the machine can do a transportation . The rated load is 250kg, under normal rotated speed of the diesel engine, speed of the fast shift is about 10km/h and that of the slow shift is about 5 km/h.

Multi-Functional Working

Dismount protection cover of the gear-box (No.2 in Figure 1), unscrew the bolts away from the rear part of the main shaft, take the cover for keys out of shaft, fasten the self-contained belt pulley or coupling onto the gear-box's main shaft's rear part with screws. Type A of common V belt is adopted for belt pulley's cross section. Rated rpm of the belt pulley is 3000 rpm. When the corresponding devices are equipped, pumping water, spraying, threshing, reaping, generating electricity, etc are realized. (Above additional implements are in exploration process. Please contact with the local distributor if you need above implements.)

Operation & Use Method of Power tiller

Assembly After Unpacking

1. Fix the main machine, insert the hexagonal output shaft into stepped box's output casing's hexagonal hole.
2. Fix the hexagonal stop casing onto the hexagonal output shaft with M6×6 socket head screws, and make the hexagonal shaft not move axially.
3. Wheel fixing: fix the wheels at the two sides of the Hexagonal output shaft, and fix them with two M8×55 bolts and M8 nuts.
4. Trailer fixing: Fix the link group onto the trailer, use the link shaft assembly for connection, insert the split pin 3×26 and insert the velocity adjustment screw into square groove of the link group, and fix it with M8×55 bolts and nuts.
5. Handle bar fixing: Two gear discs of the handle bar support aim at the discs of the handle bar support base, and adjust the positions. Fix them with M16×140 bolts, flat gasket 16 and spring gasket16.
6. Shifting bar assembly: Get the shifting bar through the groove of shift support in the handle bar support base, and insert it into the hole of the shift casing, then fix it with split pin 3.2 ×16. set the shifting bar in neutral position.
7. Assembly drawing of safety protection guard install.

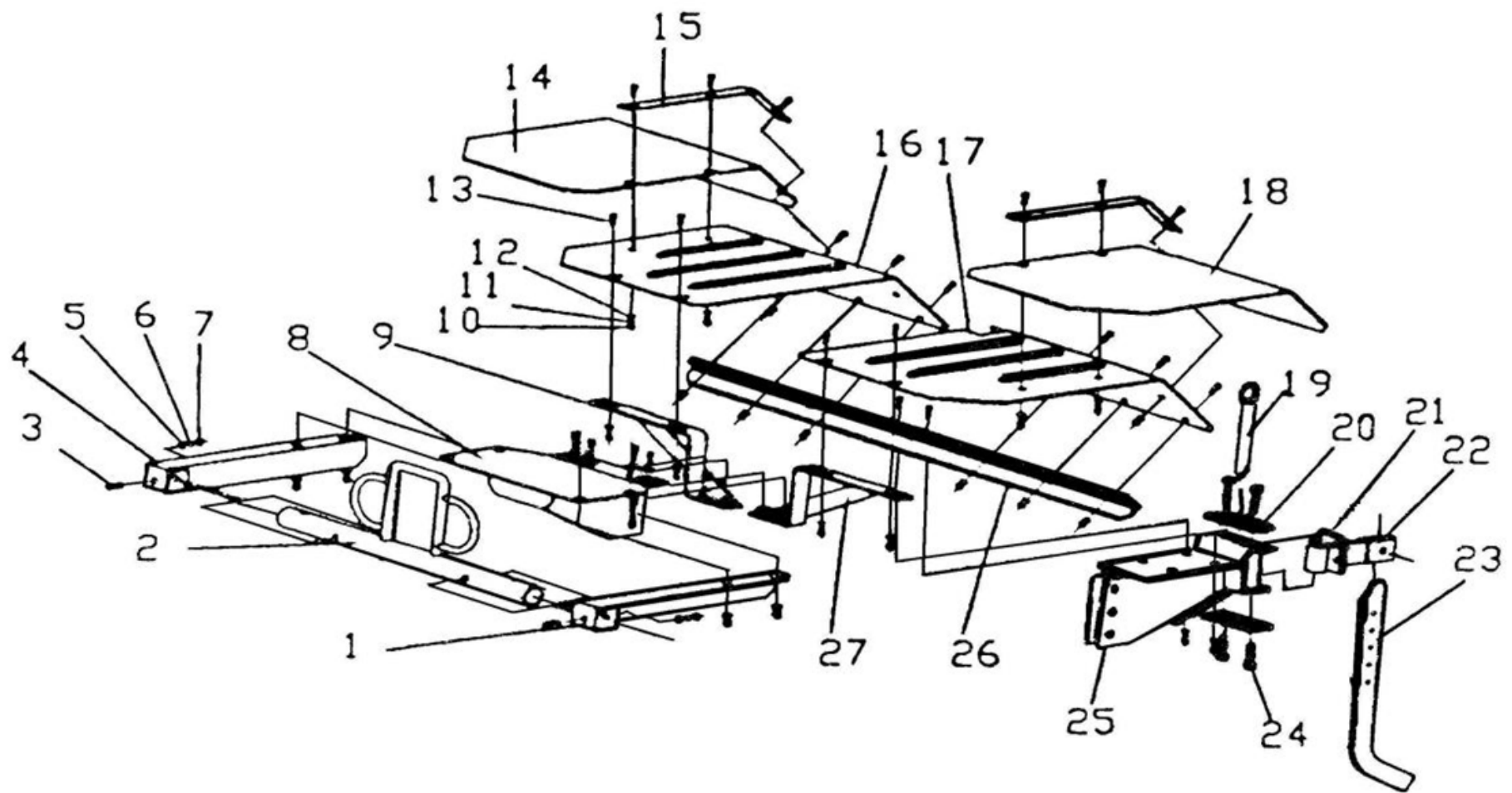

1. BRACKET OF COLLISION BUMPER(LEFT)
2. BRACKET OF COLLISION BUMPER(FRONT)
3. BOLT
4. BRACKER OF COLLISION BUMPER(RIGHT)
5. NUT
6. SPRING WASHER
7. WASHER
8. STAND (DIESEL)
9. BRACKET(RIGHT)
- 10.NUT
11. SPRING WASHER
12. WASHER
13. BOLT
14. FENDER FOR PADDY FIELD (RIGHT)
15. FIXTY OF SAFETY PROTECTION GUARD
16. SAFETY PROTECTION GUARD(RIGHT)
17. SAFETY PROTECTION GUARD(LEFT)
18. FENDER FOR PADDY FIELD(LEFT)
19. DOWEL
20. CONNECTING PLATE
21. BOLT

22. CONNECTOR JOINTING ASSEMBLY
23. DEEP FURROWING RESISTANCESTICK
24. BOLT
25. BULLING SET
26. BRCRET OF FENDER COMP
27. BRACKET (LEFT)

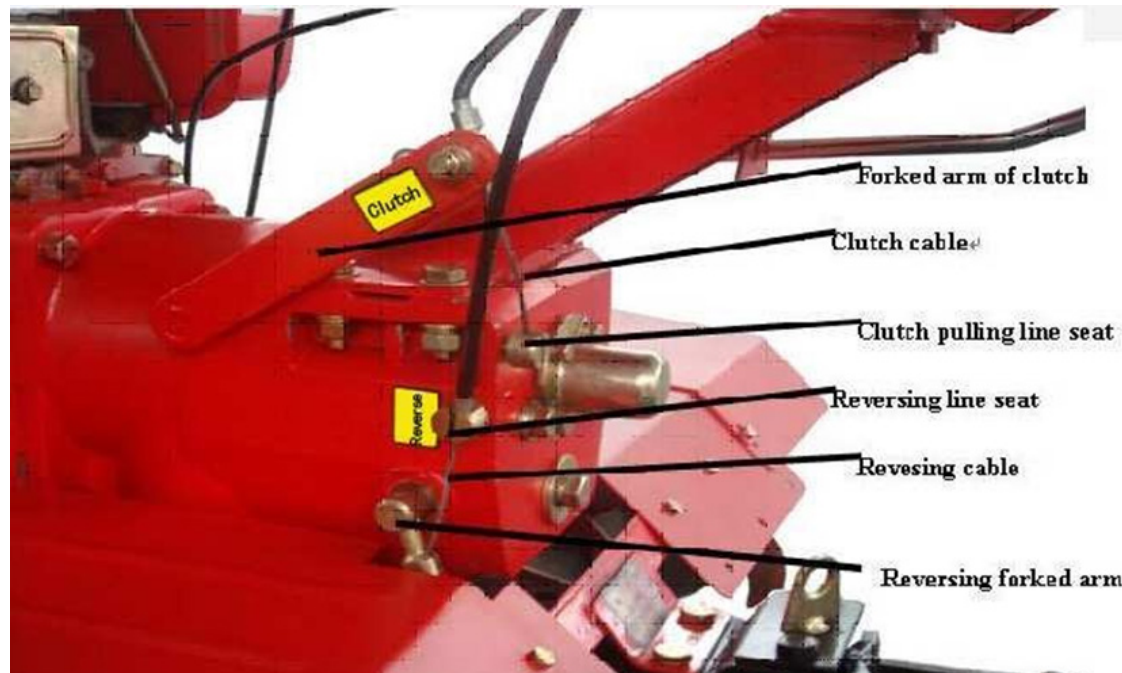
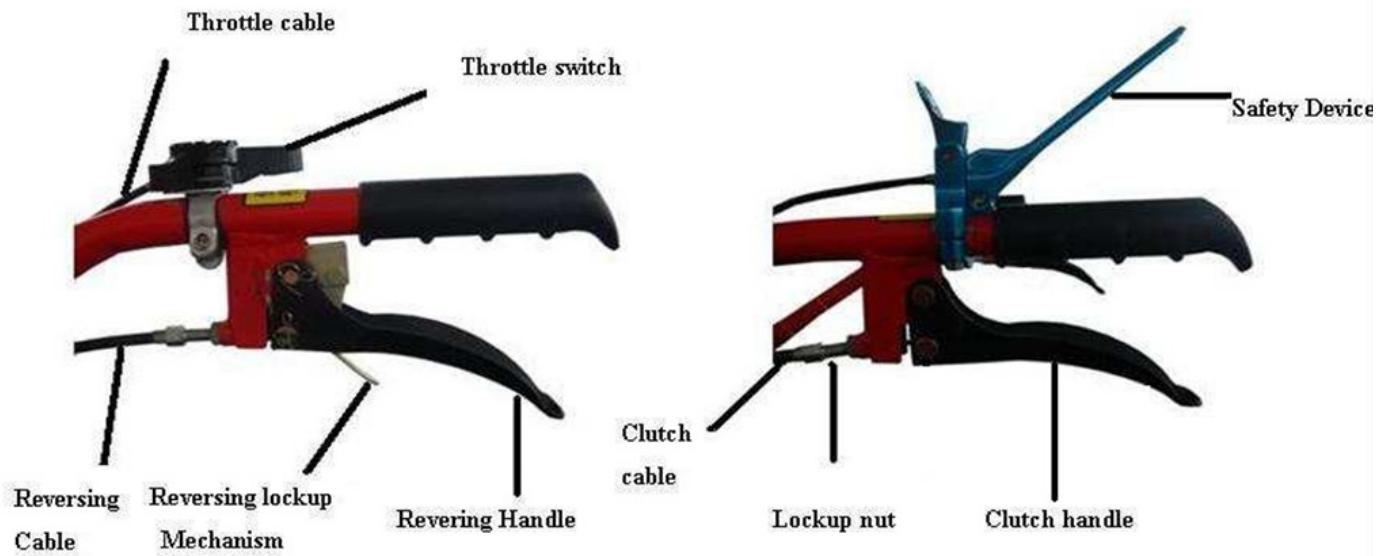

Adjustment of the reversing gear cable

Unscrew the locknut of the tie rod.

∕ Spin the tie rod clockwise until the bare handle support is the shortest.

~ Get the cable into the reversing fork shaft besides the gear-box, and ensure the joint of cable goes into the hole of the fork shaft.

⌒ Properly pull the reversing fork shaft counterclockwise, get the cable into the narrow gap of the reversing wire socket besides the gear-box, and ensure the pipe head goes into the hole of the wire socket.

* Unscrew the tie rod, grasp and loosen the clutch handle until the spring force in the clutch can reset the handle, then screw the locknut.

1 . Detailed information for the installation and adjustment of cable, refer to the disk attached.

Check and Refueling

Check whether all the connection bolts are loose or not, and fix the connection bolts according to the moment of force listed in table 3. (Refer to the instruction manual for diesel engine for the screwing moment of force bolt and nut respectively)

HANDLE CONTROL - A

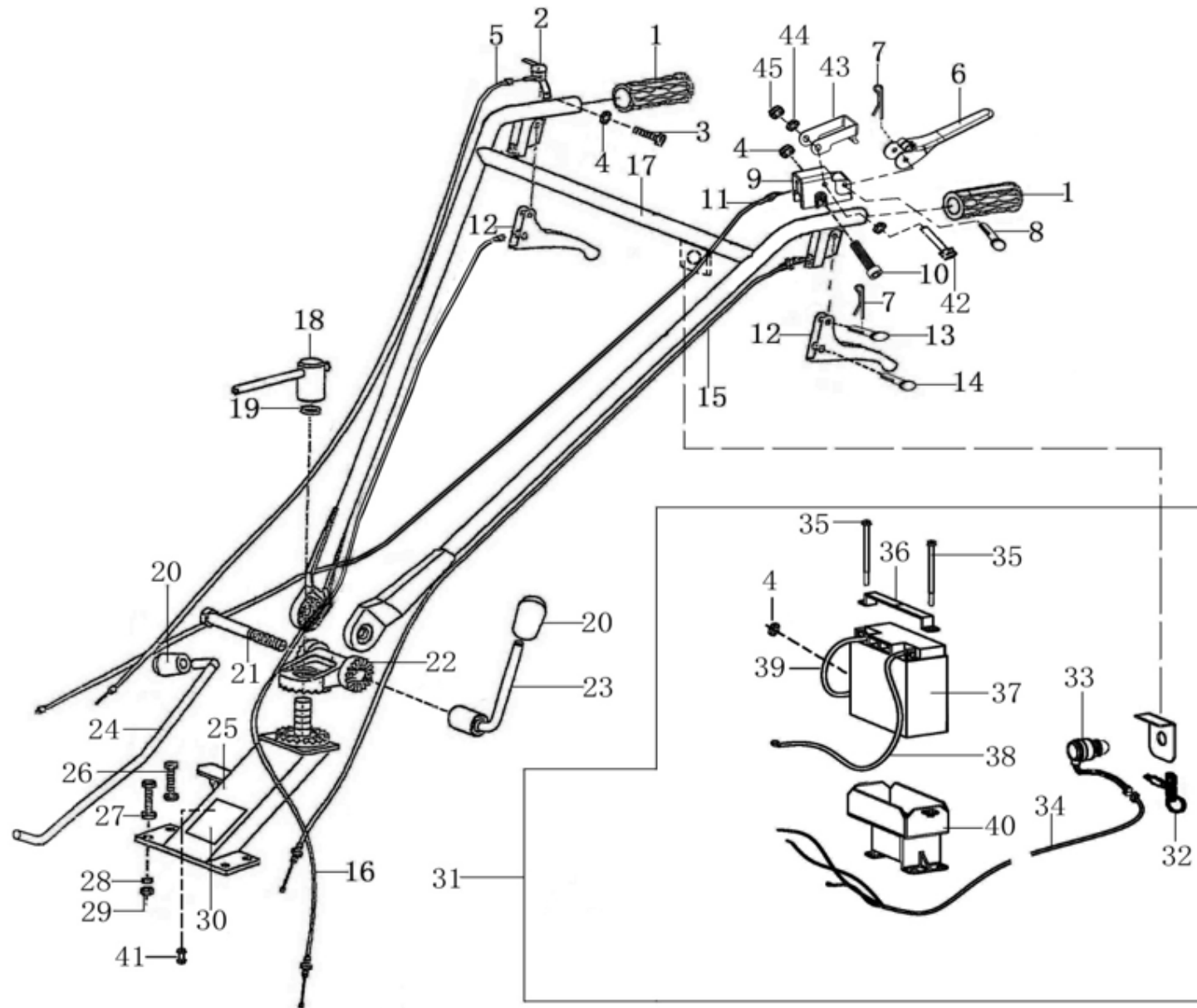

SL NO	PART NO	DESCRIPTION	SL NO	PART NO	DESCRIPTION
1	AM-RT-212-7P-WL-TA01	Handle Grip	17	AM-RT-212-7P-WL-TA17	Handle bar assy
2	AM-RT-212-7P-WL-TA02	Shut Down Switch Comp		AM-RT-212-7P-WL-TA17.1	Handle bar assy(Electric start)
3	AM-RT-212-7P-WL-TA03	Bolt	18	AM-RT-212-7P-WL-TA18	T Figure Lock Comp
4	AM-RT-212-7P-WL-TA04	Nut	19	AM-RT-212-7P-WL-TA19	Spring Washer
5	AM-RT-212-7P-WL-TA05	Throttle Cable Comp	20	AM-RT-212-7P-WL-TA20	Grip
6	AM-RT-212-7P-WL-TA06	Flameout switch	21	AM-RT-212-7P-WL-TA21	Bolt
7	AM-RT-212-7P-WL-TA07	Clip	22	AM-RT-212-7P-WL-TA22	Tray Gear
8	AM-RT-212-7P-WL-TA08	Pin	23	AM-RT-212-7P-WL-TA23	High And Low Lock Comp
9	AM-RT-212-7P-WL-TA09	Flameout switch Seat	24	AM-RT-212-7P-WL-TA24	Shift Lever
10	AM-RT-212-7P-WL-TA10	Bolt	25	AM-RT-212-7P-WL-TA25	Handle Seat Comp
11	AM-RT-212-7P-WL-TA11	Flameout switch Cable Comp	26	AM-RT-212-7P-WL-TA26	Bolt
12	AM-RT-212-7P-WL-TA12	Reverse Gear Or Clutch Grip	27	AM-RT-212-7P-WL-TA27	Washer
13	AM-RT-212-7P-WL-TA13	Pin	28	AM-RT-212-7P-WL-TA28	Spring Washer
14	AM-RT-212-7P-WL-TA14	Pin	29	AM-RT-212-7P-WL-TA29	Nut
15	AM-RT-212-7P-WL-TA15	Clutch Cable	30	AM-RT-212-7P-WL-TA30	Nameplate
16	AM-RT-212-7P-WL-TA16	Reverse Gear Cable	31	AM-RT-212-7P-WL-TA31	Startup Electric assy

SL NO	PART NO	DESCRIPTION	SL NO	PART NO	DESCRIPTION
32	AM-RT-212-7P-WL-TA32	Key			
33	AM-RT-212-7P-WL-TA33	Startup Lock			
34	AM-RT-212-7P-WL-TA34	Startup Control Cord			
35	AM-RT-212-7P-WL-TA35	Connecting Bolt			
36	AM-RT-212-7P-WL-TA36	Accumulator Fixation Board			
37	AM-RT-212-7P-WL-TA37	Accumulator Assy			
38	AM-RT-212-7P-WL-TA38	Accumulator Connecting Cord A			
39	AM-RT-212-7P-WL-TA39	Accumulator Connecting Cord B			
40	AM-RT-212-7P-WL-TA40	Base Accumulator Assy			
41	AM-RT-212-7P-WL-TA41	Screw			
42	AM-RT-212-7P-WL-TA42	Cruciform slot screw			
43	AM-RT-212-7P-WL-TA43	Clip			
44	AM-RT-212-7P-WL-TA44	Washer			
45	AM-RT-212-7P-WL-TA45	Flange bolt			

SHIFT GEAR PARTS - B

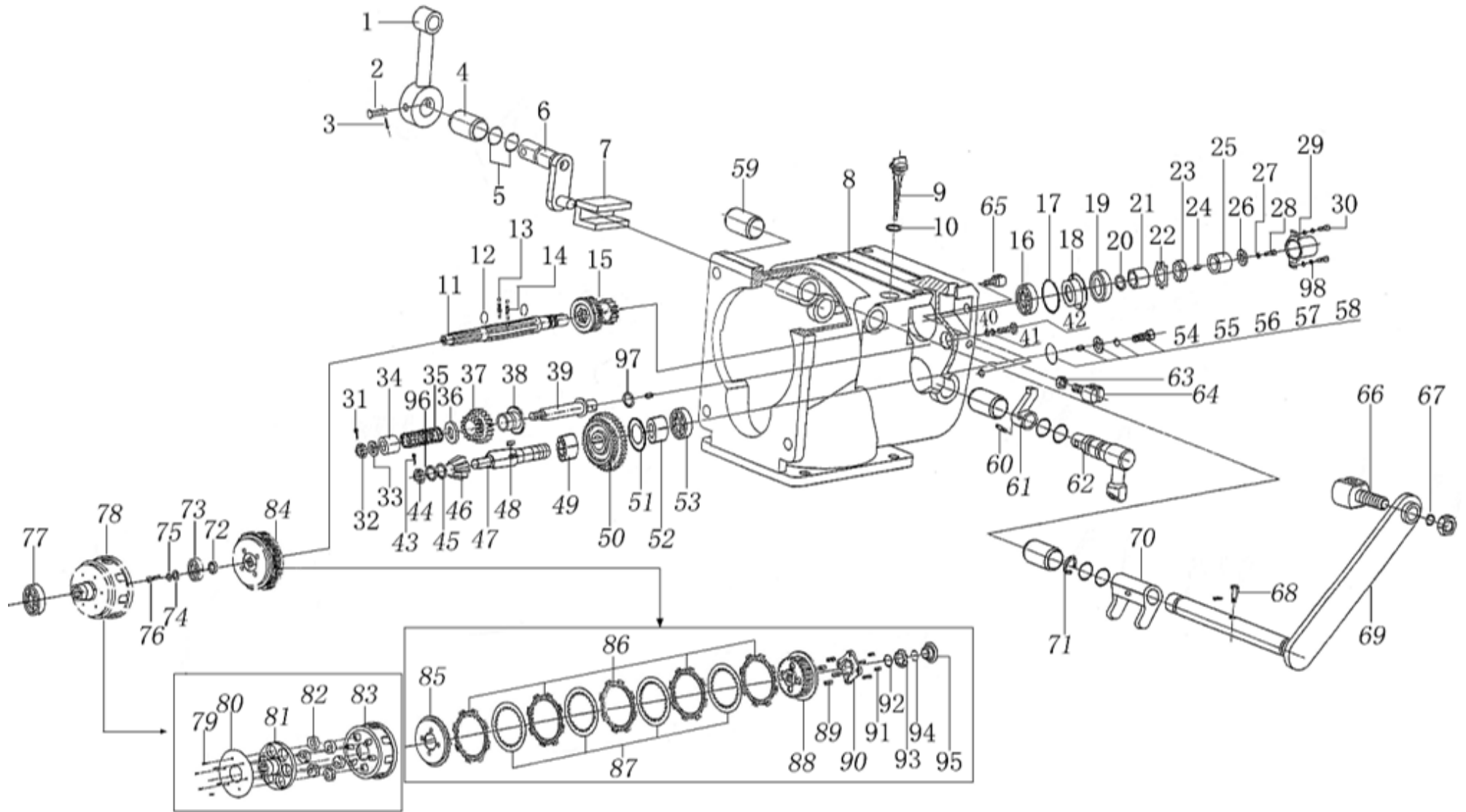

SL NO	PART NO	DESCRIPTION	SL NO	PART NO	DESCRIPTION
1	AM-RT-212-7P-WL-TB01	Sheath, Shift rod	17	AM-RT-212-7P-WL-TB17	O-ring
2	AM-RT-212-7P-WL-TB02	Pin , Shift rod	18	AM-RT-212-7P-WL-TB18	Pushing panel
3	AM-RT-212-7P-WL-TB03	Splitpin	19	AM-RT-212-7P-WL-TB19	Oil seal B
4	AM-RT-212-7P-WL-TB04	Bush Shift axes	20	AM-RT-212-7P-WL-TB20	O-ring
5	AM-RT-212-7P-WL-TB05	O-ring	21	AM-RT-212-7P-WL-TB21	Sheath, principal axes
6	AM-RT-212-7P-WL-TB06	Shift axes	22	AM-RT-212-7P-WL-TB22	Gasket
7	AM-RT-212-7P-WL-TB07	Shift fork	23	AM-RT-212-7P-WL-TB23	Nut
8	AM-RT-212-7P-WL-TB08	Shift gear box	24	AM-RT-212-7P-WL-TB24	Key
9	AM-RT-212-7P-WL-TB09	Oil stick	25	AM-RT-212-7P-WL-TB25	Sheath, Key
10	AM-RT-212-7P-WL-TB10	O-ring, oil stick	26	AM-RT-212-7P-WL-TB26	Gasket
11	AM-RT-212-7P-WL-TB11	Principal axes	27	AM-RT-212-7P-WL-TB27	Spring washer
12	AM-RT-212-7P-WL-TB12	Ring GB/T	28	AM-RT-212-7P-WL-TB28	Hex bolts
13	AM-RT-212-7P-WL-TB13	Steel ball GB/T	29	AM-RT-212-7P-WL-TB29	Protec cover, principal axes
14	AM-RT-212-7P-WL-TB14	Spring, Principal axes	30	AM-RT-212-7P-WL-TB30	Screw
15	AM-RT-212-7P-WL-TB15	Initiative gear	31	AM-RT-212-7P-WL-TB31	Splitpin
16	AM-RT-212-7P-WL-TB16	Axletree	32	AM-RT-212-7P-WL-TB32	Nut

SL NO	PART NO	DESCRIPTION	SL NO	PART NO	DESCRIPTION
33	AM-RT-212-7P-WL-TB33	Washer	49	AM-RT-212-7P-WL-TB49	Ball bearing
34	AM-RT-212-7P-WL-TB34	Restrict cover, reverse gear	50	AM-RT-212-7P-WL-TB50	Double gear, countershaft
35	AM-RT-212-7P-WL-TB35	Spring	51	AM-RT-212-7P-WL-TB51	Gasket, countershaft
36	AM-RT-212-7P-WL-TB36	Spring seat, reverse gear	52	AM-RT-212-7P-WL-TB52	Sheath, countershaft
37	AM-RT-212-7P-WL-TB37	Double gear, reverse gear	53	AM-RT-212-7P-WL-TB53	Thrust ball bearing
38	AM-RT-212-7P-WL-TB38	Pushing plate, reverse gear	54	AM-RT-212-7P-WL-TB54	O-ring
39	AM-RT-212-7P-WL-TB39	Axes, reverse gear	55	AM-RT-212-7P-WL-TB55	Column pin
40	AM-RT-212-7P-WL-TB40	Washer	56	AM-RT-212-7P-WL-TB56	Gasket
41	AM-RT-212-7P-WL-TB41	Spring washer	57	AM-RT-212-7P-WL-TB57	Spring washer
42	AM-RT-212-7P-WL-TB42	Bolt	58	AM-RT-212-7P-WL-TB58	Bolt
43	AM-RT-212-7P-WL-TB43	Splitpin GB/T	59	AM-RT-212-7P-WL-TB59	Sheath
44	AM-RT-212-7P-WL-TB44	Nut GB/T	60	AM-RT-212-7P-WL-TB60	Worm column pin
45	AM-RT-212-7P-WL-TB45	Gasket	61	AM-RT-212-7P-WL-TB61	Reverse gear fork
46	AM-RT-212-7P-WL-TB46	Initiative umbrella gear	62	AM-RT-212-7P-WL-TB62	Axes, reverse gear fork
47	AM-RT-212-7P-WL-TB47	Countershaft	63	AM-RT-212-7P-WL-TB63	Nut
48	AM-RT-212-7P-WL-TB48	Key	64	AM-RT-212-7P-WL-TB64	Seat, reverse gear cable

SL NO	PART NO	DESCRIPTION	SL NO	PART NO	DESCRIPTION
65	AM-RT-212-7P-WL-TB65	Seat, clutch cable	82	AM-RT-212-7P-WL-TB82	Cushion
66	AM-RT-212-7P-WL-TB66	Seat, clutch cable	83	AM-RT-212-7P-WL-TB83	Cover, clutch
67	AM-RT-212-7P-WL-TB67	Spring washer	84	AM-RT-212-7P-WL-TB84	Core comp, clutch
68	AM-RT-212-7P-WL-TB68	Pin ,clutch fork	85	AM-RT-212-7P-WL-TB85	Platen
69	AM-RT-212-7P-WL-TB69	Axes, clutch fork	86	AM-RT-212-7P-WL-TB86	Friction piece
70	AM-RT-212-7P-WL-TB70	Clutch fork	87	AM-RT-212-7P-WL-TB87	Driven piece
71	AM-RT-212-7P-WL-TB71	Ring	88	AM-RT-212-7P-WL-TB88	Driven plate assy
72	AM-RT-212-7P-WL-TB72	Clutch washer	89	AM-RT-212-7P-WL-TB89	Spring
73	AM-RT-212-7P-WL-TB73	Axletree	90	AM-RT-212-7P-WL-TB90	Lift slab assy
74	AM-RT-212-7P-WL-TB74	Gasket	91	AM-RT-212-7P-WL-TB91	Screw
75	AM-RT-212-7P-WL-TB75	Sawtooth locked gasket	92	AM-RT-212-7P-WL-TB92	Steel ring
76	AM-RT-212-7P-WL-TB76	Flange bolt	93	AM-RT-212-7P-WL-TB93	Fixed sheath
77	AM-RT-212-7P-WL-TB77	Axletree	94	AM-RT-212-7P-WL-TB94	Ball bearing
78	AM-RT-212-7P-WL-TB78	Core comp, clutch	95	AM-RT-212-7P-WL-TB95	Active Pushing cover
79	AM-RT-212-7P-WL-TB79	Screw	96	AM-RT-212-7P-WL-TB96	Gasket
80	AM-RT-212-7P-WL-TB80	Cover, cushion	97	AM-RT-212-7P-WL-TB97	O-ring
81	AM-RT-212-7P-WL-TB81	Spline plate, clutch	98	AM-RT-212-7P-WL-TB98	Washer

TRANSMISSION PART LIST - C

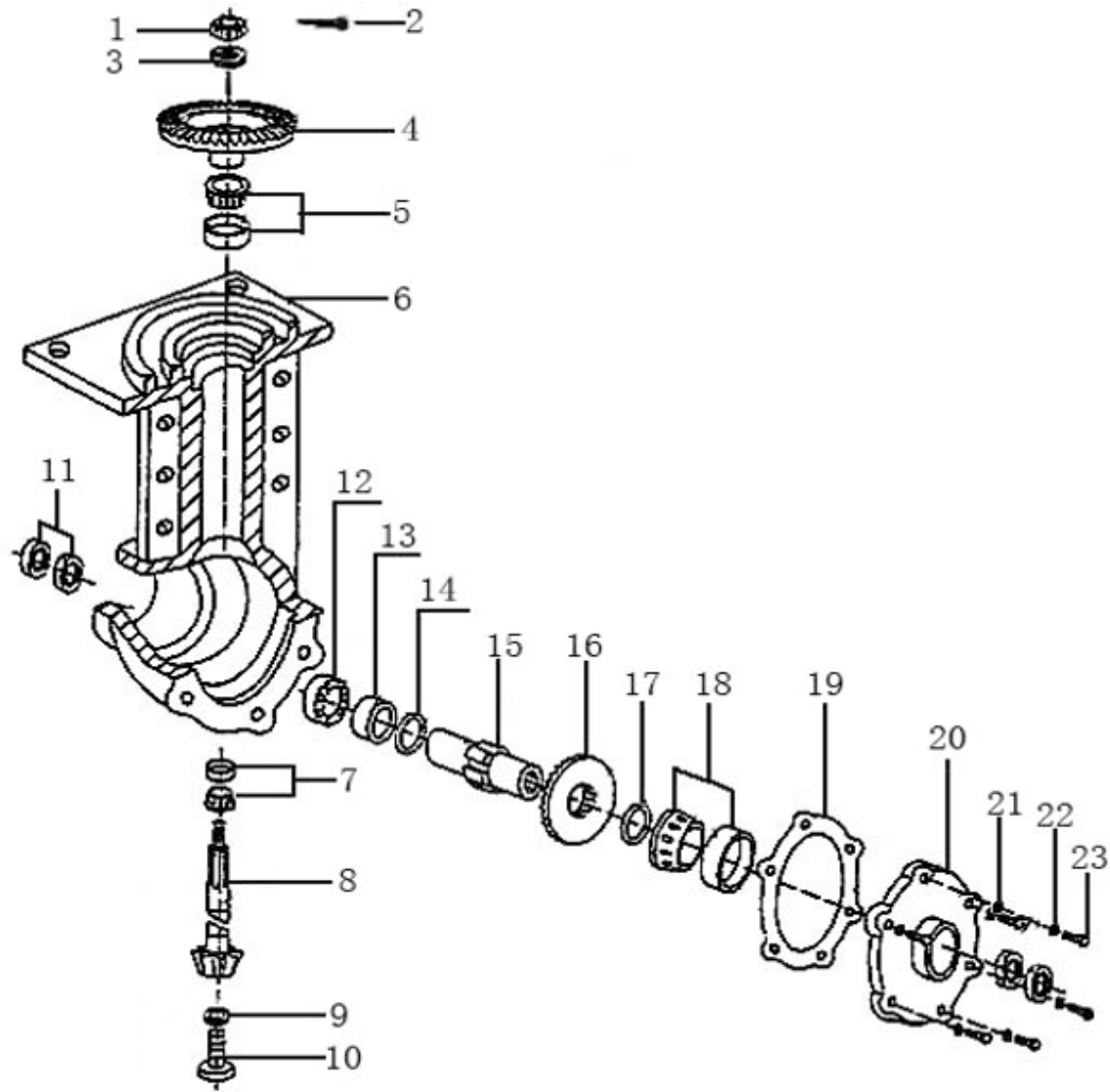

SL NO	PART NO	DESCRIPTION	SL NO	PART NO	DESCRIPTION
1	AM-RT-212-7P-WL-TC01	Nut	17	AM-RT-212-7P-WL-TC17	Gasket
2	AM-RT-212-7P-WL-TC02	Splitpin	18	AM-RT-212-7P-WL-TC18	Taper ball bearing
3	AM-RT-212-7P-WL-TC03	Spring washer	19	AM-RT-212-7P-WL-TC19	Gasket
4	AM-RT-212-7P-WL-TC04	Driven umbrella gear	20	AM-RT-212-7P-WL-TC20	Side cover, walking case
5	AM-RT-212-7P-WL-TC05	Taper ball bearing	21	AM-RT-212-7P-WL-TC21	Washer
6	AM-RT-212-7P-WL-TC06	Walking case	22	AM-RT-212-7P-WL-TC22	Spring washer
7	AM-RT-212-7P-WL-TC07	Taper ball bearing	23	AM-RT-212-7P-WL-TC23	Hex bolt
8	AM-RT-212-7P-WL-TC08	Umbrella gear axes			
9	AM-RT-212-7P-WL-TC09	O-ring			
10	AM-RT-212-7P-WL-TC10	Drain bolt			
11	AM-RT-212-7P-WL-TC11	Oil seal			
12	AM-RT-212-7P-WL-TC12	Ball bearing			
13	AM-RT-212-7P-WL-TC13	Cover, output axes			
14	AM-RT-212-7P-WL-TC14	Gasket			
15	AM-RT-212-7P-WL-TC15	Cover, flange axes			
16	AM-RT-212-7P-WL-TC16	Walking umbrella gear			

BLADES - D

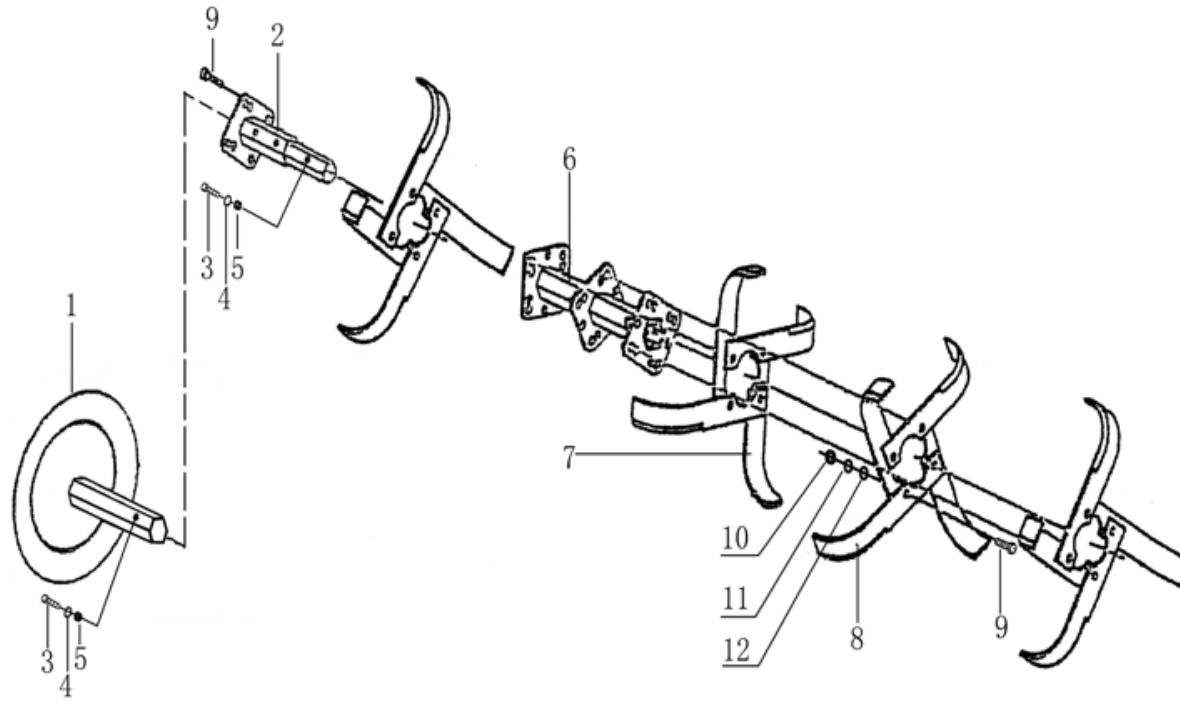

SL NO	PART NO	DESCRIPTION	SL NO	PART NO	DESCRIPTION
1	AM-RT-212-7P-WL-TD01	Round plate(optional)	7	AM-RT-212-7P-WL-TD07	Blade(L)
2	AM-RT-212-7P-WL-TD02	Counter tube	8	AM-RT-212-7P-WL-TD08	Blade(R)
3	AM-RT-212-7P-WL-TD03	Bolt	9	AM-RT-212-7P-WL-TD09	Hex bolt
4	AM-RT-212-7P-WL-TD04	Spring washer	10	AM-RT-212-7P-WL-TD10	Nut
5	AM-RT-212-7P-WL-TD05	Nut	11	AM-RT-212-7P-WL-TD11	Washer
6	AM-RT-212-7P-WL-TD06	Main tube	12	AM-RT-212-7P-WL-TD12	Spring washer

WHEEL PARTS - E

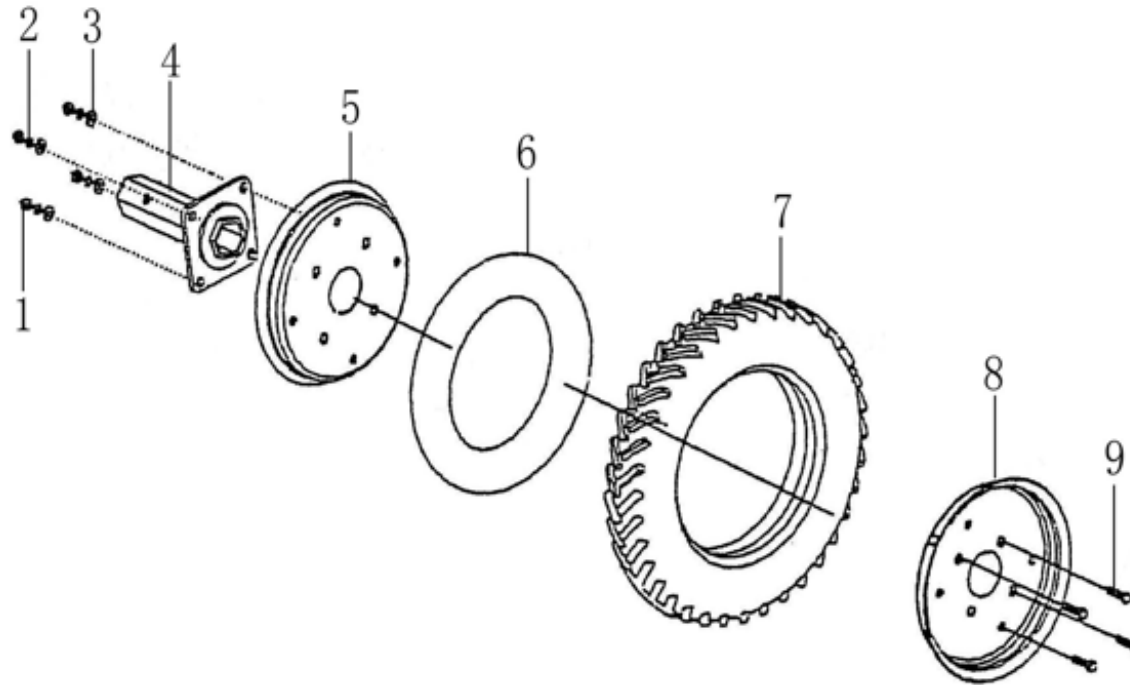

SL NO	PART NO	DESCRIPTION	SL NO	PART NO	DESCRIPTION
1	AM-RT-212-7P-WL-TE01	Nut	6	AM-RT-212-7P-WL-TE06	Inner tube
2	AM-RT-212-7P-WL-TE02	Spring washer	7	AM-RT-212-7P-WL-TE07	Outer rubber tyre
3	AM-RT-212-7P-WL-TE03	Washer	8	AM-RT-212-7P-WL-TE08	Spoke (L)
4	AM-RT-212-7P-WL-TE04	Wheel axle	9	AM-RT-212-7P-WL-TE09	Hex bolt
5	AM-RT-212-7P-WL-TE05	Spoke (R)			

JOINT PARTS - F

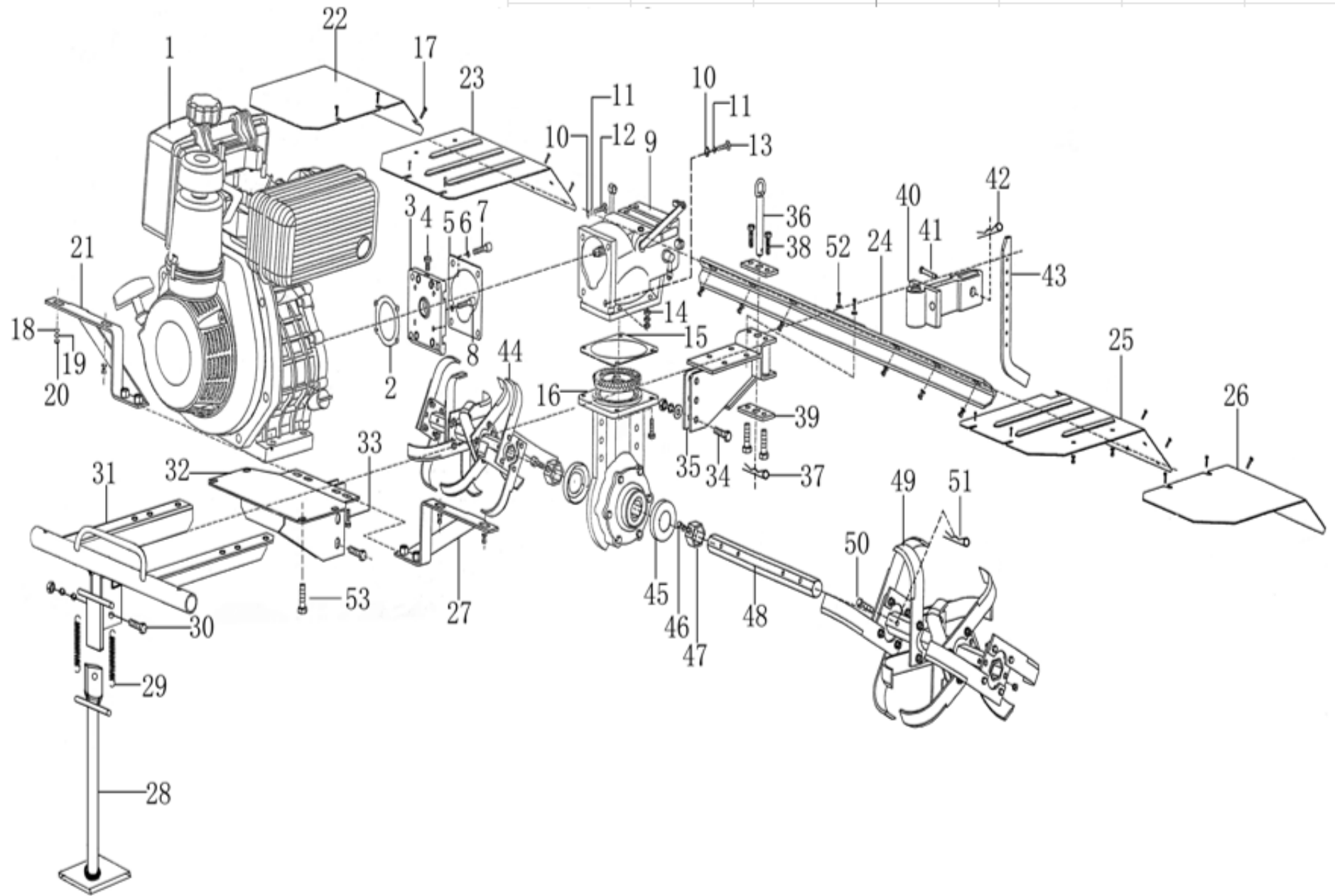





SL NO	PART NO	DESCRIPTION	SL NO	PART NO	DESCRIPTION
1	AM-RT-212-7P-WL-TF01	Petrol engine comp	17	AM-RT-212-7P-WL-TF17	Bolts
	AM-RT-212-7P-WL-TF1.1	Diesel engine comp(Electric start)	18	AM-RT-212-7P-WL-TF18	Washer
2	AM-RT-212-7P-WL-TF02	Flange gasket	19	AM-RT-212-7P-WL-TF19	Spring washer
3	AM-RT-212-7P-WL-TF03	Flange	20	AM-RT-212-7P-WL-TF20	Nut
4	AM-RT-212-7P-WL-TF04	Bolt	21	AM-RT-212-7P-WL-TF21	Frame(R)
5	AM-RT-212-7P-WL-TF05	Airproof gasket, gear box	22	AM-RT-212-7P-WL-TF22	Vice Dust cover(R)
6	AM-RT-212-7P-WL-TF06	Spring washer	23	AM-RT-212-7P-WL-TF23	Bust cover (R)
7	AM-RT-212-7P-WL-TF07	Screw	24	AM-RT-212-7P-WL-TF24	Frame, Dust cover (Back)
8	AM-RT-212-7P-WL-TF08	Screw	25	AM-RT-212-7P-WL-TF25	Dust cover(L)
9	AM-RT-212-7P-WL-TF09	Gear box comp	26	AM-RT-212-7P-WL-TF26	Vice Dust cover(L)
10	AM-RT-212-7P-WL-TF10	Washer	27	AM-RT-212-7P-WL-TF27	Frame(L)
11	AM-RT-212-7P-WL-TF11	Spring washer	28	AM-RT-212-7P-WL-TF28	Bumper support
12	AM-RT-212-7P-WL-TF12	Bolts	29	AM-RT-212-7P-WL-TF29	Spring
13	AM-RT-212-7P-WL-TF13	Bolts	30	AM-RT-212-7P-WL-TF30	Falnge bolt
14	AM-RT-212-7P-WL-TF14	Nut	31	AM-RT-212-7P-WL-TF31	Bumper comp
15	AM-RT-212-7P-WL-TF15	Core comp, clutch	32	AM-RT-212-7P-WL-TF32	Support frame, engine
16	AM-RT-212-7P-WL-TF16	Gear box comp	33	AM-RT-212-7P-WL-TF33	Bolts

SL NO	PART NO	DESCRIPTION	SL NO	PART NO	DESCRIPTION
34	AM-RT-212-7P-WL-TF34	Bolts,	51	AM-RT-212-7P-WL-TF51	Clip
35	AM-RT-212-7P-WL-TF35	Dragging assy	52	AM-RT-212-7P-WL-TF52	Flange bolt
36	AM-RT-212-7P-WL-TF36	Pin with ring	53	AM-RT-212-7P-WL-TF53	Flange bolt
37	AM-RT-212-7P-WL-TF37	Clip			
38	AM-RT-212-7P-WL-TF38	Bolts			
39	AM-RT-212-7P-WL-TF39	Connection plate			
40	AM-RT-212-7P-WL-TF40	Connection frame			
41	AM-RT-212-7P-WL-TF41	Pin			
42	AM-RT-212-7P-WL-TF42	Clip			
43	AM-RT-212-7P-WL-TF43	Resistance rod			
44	AM-RT-212-7P-WL-TF44	Dry land blade comp(R)			
45	AM-RT-212-7P-WL-TF45	Dust protect cover			
46	AM-RT-212-7P-WL-TF46	Bolts			
47	AM-RT-212-7P-WL-TF47	Flange fix sheath			
48	AM-RT-212-7P-WL-TF48	Flange output axes			
49	AM-RT-212-7P-WL-TF49	Dry land blade comp(L)			
50	AM-RT-212-7P-WL-TF50	Pin			





WARRANTY CARD

CUSTOMER COPY

DATE _____	DATE OF DELIVERY _____	DEALERS OFFICIAL SEAL	DEALERS SIGN _____
PURCHASERS NAME & ADDRESS _____ _____	 CUSTOMER SIGN		
PRODUCT NAME	PRODUCT SERIAL NO.	INVOICE/DN NO.	
			





I/Will accept the terms and conditions of warranty as in the warranty card

DEALERS COPY

DATE _____	DATE OF DELIVERY _____	DEALERS OFFICIAL SEAL	DEALERS SIGN _____
PURCHASERS NAME & ADDRESS _____ _____	 CUSTOMER SIGN		
PRODUCT NAME	PRODUCT SERIAL NO.	INVOICE/DN NO.	
			

I/Will accept the terms and conditions of warranty as in the warranty card

COMPANY COPY

DATE _____	DATE OF DELIVERY _____	DEALERS OFFICIAL SEAL	DEALERS SIGN _____
PURCHASERS NAME & ADDRESS _____ _____	 CUSTOMER SIGN		
PRODUCT NAME	PRODUCT SERIAL NO.	INVOICE/DN NO.	
			

I/Will accept the terms and conditions of warranty as in the warranty card

1. LIMITED WARRANTY PERIOD : For a period of six months from the date of Sale / delivery of the product which ever is earlier. 2. LIMITED WARRANTY OBLIGATION : Replacement of defective part(s) by authorized dealer are free of charges. If found defective by reasons of defective material / poor workmanship, parts will be replaced and there will be no value re-imburement. 3. TERMS & CONDITIONS : a. Claims under warranty will be accepted on submission of Warranty Card duly filled and stamped by authorized dealer together with the original purchase document. : b. Shipping / transportation / Incidental charges incurred in replacing defective parts under warranty shall be borne by the purchaser

WARRANTY null & void if

- (i) Lack of maintenance, (ii) Incorrect use of the machine or tampering, (iii) Use of non-genuine spare parts, (iv) Usage of acids, solvents, or any flammable materials, (v) Non-usage of filter water / clear water / soft water & using water above 40°C temperature, (vi) While using the pressure washers to draw water which is contaminated with dust & solvents (eg. paint thinners, gasoline, oil, etc.), (vii) Repair done by unauthorized service people, (viii) Those parts subject to wear & tear due to normal operations and plastic parts, rubber items etc, (ix) Loose connections, faulty electrical fixtures & fluctuations in power supply.
- 4. Should any failure occur during or after the warranty period, customer does not have the right to interrupt payment / price discount.
- 5. Incidental or consequential damages like inconvenience commercial loss, loss of tie, mental agony etc.
- 6. Loss of any nature due to operation or non-operation is not covered under warranty.
- 7. All free service are at Dealer's service point only.
- 8. Warranty ceases if service is not done periodically.
- 9. The attached card should be completed and returned to Ratnagiri Impex Pvt. Ltd. for registration immediately after sale / delivery.
- 10. The warranty is void unless you register the warranty card with Ratnagiri Impex Pvt. Ltd.
- 11. The decision of Ratnagiri Impex Pvt. Ltd., in settling the warranty is final in all respects.
- 12. All disputes are subject to Bangalore Courts Jurisdiction

1. LIMITED WARRANTY PERIOD : For a period of six months from the date of Sale / delivery of the product which ever is earlier. 2. LIMITED WARRANTY OBLIGATION : Replacement of defective part(s) by authorized dealer are free of charges. If found defective by reasons of defective material / poor workmanship, parts will be replaced and there will be no value re-imburement. 3. TERMS & CONDITIONS : a. Claims under warranty will be accepted on submission of Warranty Card duly filled and stamped by authorized dealer together with the original purchase document. : b. Shipping / transportation / Incidental charges incurred in replacing defective parts under warranty shall be borne by the purchaser.

WARRANTY null & void if

- (i) Lack of maintenance, (ii) Incorrect use of the machine or tampering, (iii) Use of non-genuine spare parts, (iv) Usage of acids, solvents, or any flammable materials, (v) Non-usage of filter water / clear water / soft water & using water above 40°C temperature, (vi) While using the pressure washers to draw water which is contaminated with dust & solvents (eg. paint thinners, gasoline, oil, etc.), (vii) Repair done by unauthorized service people, (viii) Those parts subject to wear & tear due to normal operations and plastic parts, rubber items etc, (ix) Loose connections, faulty electrical fixtures & fluctuations in power supply.
- 4. Should any failure occur during or after the warranty period, customer does not have the right to interrupt payment / price discount.
- 5. Incidental or consequential damages like inconvenience commercial loss, loss of tie, mental agony etc.
- 6. Loss of any nature due to operation or non-operation is not covered under warranty.
- 7. All free service are at Dealer's service point only.
- 8. Warranty ceases if service is not done periodically.
- 9. The attached card should be completed and returned to Ratnagiri Impex Pvt. Ltd. for registration immediately after sale / delivery.
- 10. The warranty is void unless you register the warranty card with Ratnagiri Impex Pvt. Ltd.
- 11. The decision of Ratnagiri Impex Pvt. Ltd., in settling the warranty is final in all respects.
- 12. All disputes are subject to Bangalore Courts Jurisdiction

1. LIMITED WARRANTY PERIOD : For a period of six months from the date of Sale / delivery of the product which ever is earlier. 2. LIMITED WARRANTY OBLIGATION : Replacement of defective part(s) by authorized dealer are free of charges. If found defective by reasons of defective material / poor workmanship, parts will be replaced and there will be no value re-imburement. 3. TERMS & CONDITIONS : a. Claims under warranty will be accepted on submission of Warranty Card duly filled and stamped by authorized dealer together with the original purchase document. : b. Shipping / transportation / Incidental charges incurred in replacing defective parts under warranty shall be borne by the purchaser.

WARRANTY null & void if

- (i) Lack of maintenance, (ii) Incorrect use of the machine or tampering, (iii) Use of non-genuine spare parts, (iv) Usage of acids, solvents, or any flammable materials, (v) Non-usage of filter water / clear water / soft water & using water above 40°C temperature, (vi) While using the pressure washers to draw water which is contaminated with dust & solvents (eg. paint thinners, gasoline, oil, etc.), (vii) Repair done by unauthorized service people, (viii) Those parts subject to wear & tear due to normal operations and plastic parts, rubber items etc, (ix) Loose connections, faulty electrical fixtures & fluctuations in power supply.
- 4. Should any failure occur during or after the warranty period, customer does not have the right to interrupt payment / price discount.
- 5. Incidental or consequential damages like inconvenience commercial loss, loss of tie, mental agony etc.
- 6. Loss of any nature due to operation or non-operation is not covered under warranty.
- 7. All free service are at Dealer's service point only.
- 8. Warranty ceases if service is not done periodically.
- 9. The attached card should be completed and returned to Ratnagiri Impex Pvt. Ltd. for registration immediately after sale / delivery.
- 10. The warranty is void unless you register the warranty card with Ratnagiri Impex Pvt. Ltd.
- 11. The decision of Ratnagiri Impex Pvt. Ltd., in settling the warranty is final in all respects.
- 12. All disputes are subject to Bangalore Courts Jurisdiction



FREE SERVICE COUPON (30DAYS/30HRS. WHICHEVER IS EARLIER)

MODEL	<input type="text"/>	SERIAL NUMBER	<input type="text"/>
PDI DATE	SERVICE NO.	PURCHASE BILL NO.	DATE
<input type="text"/>	<input type="text"/>	<input type="text"/>	<input type="text"/>
DEALERS OFFICE SEAL	OPERATIONS		
<input type="text"/>	<ol style="list-style-type: none"> 1. Check and test the fuel mixture 3. Check , clean and adjust the spark plug 5. Check and sparken the cutting tools 7. Start and check the noise, vibration, loosen etc.. 	<ol style="list-style-type: none"> 2. check and clean the air filter 4. Check and adjust the carburetor tuning 6. Product familirisation on usage 8. Routine maintenance and shortage. 	

FREE SERVICE COUPON (30DAYS/30HRS. WHICHEVER IS EARLIER)

MODEL	<input type="text"/>	SERIAL NUMBER	<input type="text"/>
PDI DATE	SERVICE NO.	PURCHASE BILL NO.	DATE
<input type="text"/>	<input type="text"/>	<input type="text"/>	<input type="text"/>
DEALERS OFFICE SEAL	OPERATIONS		
<input type="text"/>	<ol style="list-style-type: none"> 1. Check and test the fuel mixture 3. Check , clean and adjust the spark plug 5. Check and sparken the cutting tools 7. Start and check the noise, vibration, loosen etc.. 	<ol style="list-style-type: none"> 2. check and clean the air filter 4. Check and adjust the carburetor tuning 6. Product familirisation on usage 8. Routine maintenance and shortage. 	

FREE SERVICE COUPON (30DAYS/30HRS. WHICHEVER IS EARLIER)

MODEL	<input type="text"/>	SERIAL NUMBER	<input type="text"/>
PDI DATE	SERVICE NO.	PURCHASE BILL NO.	DATE
<input type="text"/>	<input type="text"/>	<input type="text"/>	<input type="text"/>
DEALERS OFFICE SEAL	OPERATIONS		
<input type="text"/>	<ol style="list-style-type: none"> 1. Check and test the fuel mixture 3. Check , clean and adjust the spark plug 5. Check and sparken the cutting tools 7. Start and check the noise, vibration, loosen etc.. 	<ol style="list-style-type: none"> 2. check and clean the air filter 4. Check and adjust the carburetor tuning 6. Product familirisation on usage 8. Routine maintenance and shortage. 	

DOS

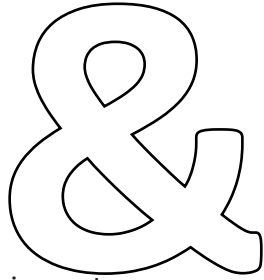

DONT'S

attempting to use the equipments.

1. Always read the instruction manual supplied along with the equipments and understand the correct installation and operating procedures before

trousers and jackets while operating potentially dangerous machines
2. It is important to use the personal protection equipments such as head helmet with visor, ear defenders, goggles, safety gloves, cut resistant shoes,
3. Avoid untrained persons using the equipments. Children must not be allowed to handle these equipments
4. Always use genuine spares and accessories in repairs and usage to derive maximum life of the equipments.
5. Always keep the equipments in good working condition to minimize loss of output as well as to reduce the pollution and save the environment
6. Do not use the machine within range of persons unless they wear protective clothing
7. Do not operate the machine when fatigued or under the influence of alcohol or drugs
8. For more query kindly contact for our Service Center/Dealer/ franchise

NO. 1 CHOICE OF FARMERS SINCE 1999



Marketed by.
**ratnagiri
impex**
BRINGING YOU THE FUTURE... NOW

RATNAGIRI IMPEX PVT., LTD.,

Annapurna House, #1 / 1G, 7th Cross, New
Guddadahalli

Mysore Road, Bangalore - 560 026

Missed Call : 7393 938 938

Email: ask@agrimart.in