

User Manual

AMTH-V120-60-CLASSIC TEA HARVESTER



DISCLAIMER: DUE TO CONSTANT UPGRADATION, FEATURES AND SPECIFICATIONS ARE SUBJECT TO CHANGE WITHOUT NOTICE



BEFORE OPERATING THIS MACHINE,
PLEASE READ THESE INSTRUCTIONS CAREFULLY



Good Products – Great Values

Dear Sir/Madam,

Thank you for choosing Agrimate product. You are the proud owner of high technology and durable machine. Trust that our franchisee/dealer installed the product and explained you about the usage and service instructions. Please visit our authorised dealer for your future requirement of our other equipments, genuine spares, accessories and service. Service coupons are attached with this manual and you can avail free service to keep your machine fit always to use on demand.

About Ratnagiri

We import and market of high quality of agriculture wide range of equipment's Which we are selling through our authorized franchisee or dealer network. We are in this field from past 20 years serving the former community. For further details, you may please visit our website www.agrimart.in, Tool Free No: 1800-425-3036.

Range of Brands



Our Retail Formats



Agriculture | Horticulture | Sericulture | Plantations | Forestry | Garden | Health care

TECHNICAL PARAMETERS

Product model	AMTH-V120-60-Classic
Engine transmission mode	Automatic centrifugal clutch
Clutch bonding rotating rate	3700-3800
Blade rotating direction	PF-25/ Reciprocating type
Engine model	1E34F
Engine power	0.75
Engine standard rotating rate	7500
Displacement	25.4cc
Method of starting	Recoil starting
Way of ignition	CDI
Fuel model	2-stroke gasoline
Fuel used	Ratio of fuel and lubricant 25-30:1

1. Preface

Thanks for purchasing and utilizing our company's product, and please read the instructions of the product and the engine before operating it so that accidents or injuries can be avoided. After reading, please keep the instructions for whenever you need.

2. Safety instruction

1. Please accept the safety operation guidance in advance if the users have little knowledge in operating the machine and after that, the machine is available.

2. The machine can't be used by the following crowd

(1) Drunk people (2) Madmen (3) Children and pregnant women

(4) People who are unable to operate the machine because of overtoil illness and drug allergy

3. Operation of clothing

1) Long-sleeved clothes and trousers should be worn, but the clothes with wide cuffs should be avoided.

- (2) The cap and the glasses should be worn
- (3) A pair of glove is needed when it is examined and taken good care of
- (4) Slippery shoes should be avoided

4. No smoking and open flames

- (1) The placement of the fuel should be valued and the places that are easy to catch fire are avoided
- (2) No smoking when the engine is being operated and the fuel is supplied
- (3) The engine should be stopped when the fuel is supplied. In addition; please dry the fuel on the engine on the occasion that the machine turns upside down or the engine is splashed with the fuel when the fuel is supplied

3. The Connection of the 4C-60 Tea Harvester

1. Pull up the pin on the engine output hole, and then put the end of the flexible shaft cover with the hole into the hole.
2. Turn around the flexible shaft cover to make the pin insert into the hole, therefore, the fixing of the part of the flexible shaft is finished.
3. On the part of the flexible shaft cover with the groove, on one hand, please turn around the square flexible shaft slowly, on the other, push it inwards to make the flexible shaft stick into the square hole of the engine.

- Adjust the flexible shaft and the square hole of the actuating shaft, push the flexible shaft cover with the groove into the flexible shaft setting.
- Stick into the flexible shaft pin and install the cotter pin .Therefore the installation of the flexible shaft is completed.

5. Precautions before operation

- Examination is needed before operation. Please entrust the exclusive shop to fix the machine if it is necessary to adjust the spare parts.
- Objects for examination before operation.

Examination	Content	Approach
Outlook	Frayed or loose?	Reinforce it
Fastener	Dropped off or loose?	Fasten it
Gear case	Grease supplied?	Supply the grease every20-30hrs once
Blades	Frayed, broken, or deformed/Lubricant?	Change the spare parts/oil
Air filter	Polluted?	Clarify it
Fuel tank	Fuel? The fuel tank cover loose?	Oil/fasten it
Throttle switch	Smooth to operate it from low to high speed?	Adjust/change the spare parts
Engine switch	ON, OFF works well?	Chang the spare parts
Blade adjusted nut	The gap of blade well adjusted?	Adjust it
Handle	Fixed	Adjust it

6. Precautions of Operation

- The fuel must be used with 90# motor petrol and the 2-stroke engine oil, the proportion of the petrol and the engine oil must be correct, in the 1st 20 hrs, the mixing ratio of the petrol and the engine oil is 25:1 and later it will be changed into 30:1.
- No sudden halt of the engine with the high speed operation. The idling speed is adjusted into 2300-2700r/min, no more casual adjustment.
- For per hour of the rotation of the blade, please oil it once with HG-10 motor petrol, and correctly adjust the blade gap.

4. Pour the ZFG-10 compound calcium-based grease into the transmission case for every 8-10 hr operation.
5. No severe collision of the machine when moved.
6. Tea Harvester can't be used as hedge trimmers.
7. Never touch the blade during the operation of the engine, even under the condition of the separation of the clutch.
8. Stop the engine when the workplace is changed or the termination of the operation, even under the condition of the short distance.
9. Never touch the spark plug during the operation of the engine.
10. The curved degree for the flexible shaft of the single tea Harvester should be proper to avoid being broken. Before operation, please wipe the butter of high temperature on the flexible shaft and stick the tube into it and then pull it several times.

7. Startup and Halt of the Engine

1. Press the oil pump several times before startup, as the fuel goes into the carburetor, then the air could come out, at the same time, please guarantee the close of the throttle control handle.
2. As the engine is at the state of cooling or started up in winter, please open the circuit switch and close the choke valve of the carburetor.
3. Press the engine and pull the starting rope.
4. After starting the engine, the users should accelerate the throttle to make it run idly for 2-3min to keep the engine warm, and then reinforce the throttle to make it work normally.
5. **To stop:** Make the throttle switch stay at the low-speed position, reduce the rotating rate of the engine, and keep the cooling operation for 2-3min, then close the circuit switch.

8. Reparation and Adjustment of Tea Harvester

1. As the blade is the high-speed sliding components, therefore, the lubricant must be poured into once per hour and the blade needs oiling with HG-10 motor petrol.
2. Examine and adjust the blade gap. After worked for a certain period, the normal gap of blade will be changed either for the fray of the blade or for the loose of the bolts (about 0.05mm). Therefore, the operation of the blade must be examined, as well as the loose of the bolts and the gap of the blade. The fitness of the blade gap determines the function of plucking and cutting. Overlarge gap will make the blade easy to break,, which will not only have a negative impact on the quality of the tea, but also result in the unevenness of the surface of the tea garden; on the contrary, it is difficult for the operation of the blade with too small gap, or even the blade will be broken easily.

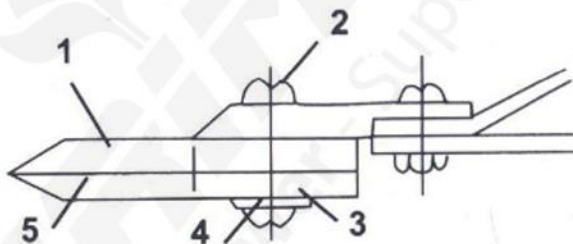

1. The upper blade 2. Nut 3. Gasket 4. M6 bolt 5. The nether blade

- 1) Loosen the nut;
- 2) Use the Phillips screwdriver to tighten the screws and then withdraw them for 3/8circle;
- 3) Tighten the nut, at the same time, the blade adjusted gasket should be moved flexibly;
- 4) Oil the blade with lubricant;
- 5) Start the engine to make the blade operate with high speed for 1 min;
- 6) Stop the engine and touch the nut. It works well if the hand bears the tem perature of the nut; if not, loosen the bolt and adjust it to the standard.

9. Questions and Answers

(1) Unable to start

Differences		Reasons	Approaches
No spark during fire-lighting of the spark plug	The spark pl plug	Moistness of the pole	Dry
		The restoration of carbon of the pole	Clean
		Chap of the insulator or low insulation	Change
		Too small/overlarge electrode gap	Adjust 0.5-0.6mm
		The injury of the electrode	Change
	Good compression	Too thick fuel	Adjust the carburetor
		The use of bad fuel	Change the good fuel
Spark during fire-lighting of the spark plug	Bad compression	Badly worn of the cylinder, piston and piston ring	Change
	Carburetor	No fuel	Supply
		Orifice plugging	Eliminate
		The block of the filter network	Clean
	Fuel unsupplied	The loose of the inlet pipe and the carburetor	Fasten

(2) Short of power

Differences	Reasons	Approaches
Good compression no burning flameout	The air has come into the seam of the inlet pipe	Fasten
	The air has come into the inlet pipe and carburetor	Airproof and fasten
	The fuel is mixed with water	Change the high-quality fuel
	The piston has a burning smell	Clean every spare parts
	Carbon piled around	Clean
Overheat	Too thin fuel	Adjust the carburetor
	Dust piled on the fan cover and cylinder cooling pin	Eliminate
Vibration noise(abnormal)	Low-quality fuel	Change high-quality fuel
	Carbon piled in the fuel cell	Clean
Others	The block of the air filter	Clean
	Overload	Proper load

(3) Halt of the Operation

Differences	Reasons	Approaches
Sudden halt of the operation	Piston sintering	Revise the piston and cylinder with file/change the sintering ring
	Short circuit for the piling of the carbon	Clean the carbon
	Problems is the magneto	Examine
	Breakdown of the spark plug cap	Embed as the original form
Halt for the low rotating rate	Scarce fuel	Fill
	The block of the interior carburetor	Examine and clean
	The fuel is mixed with water	Fulfill the fuel again

(4) Halt Difficulty

Differences	Reasons	Approaches
Carburetor	Overheat of the piston and spontaneous combustion inside	Eliminate the carbon of the cylinder and the piston
Others	Red and hot of the top of the spark plug	Eliminate the electrode and adjust the gap(0.5-0.6mm)
	Cable loss	Insert into

10. Appendix

(1) 1Engine Data

Engine model	1E34F	/
Displacement	25.4CC	/
Max.power	0.75KW/7500rpm	/
Fuel tank capacity	0.6L	/
Ratio of fuel and lubricant	The 1 st 20hours	25:1
	20hours later	30:1

PART DIAGRAM OF AMTH-V120-60-CLASSIC TEA HARVESTER

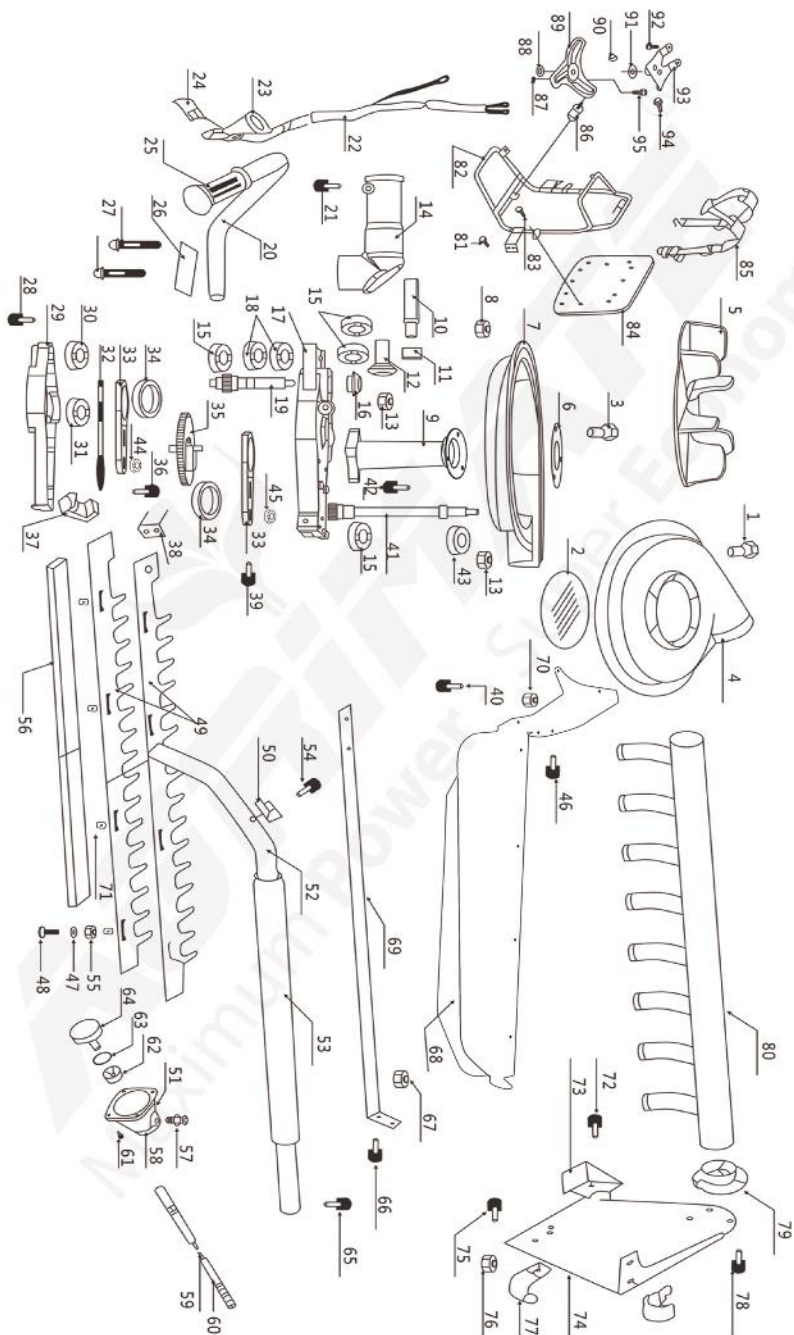

SPARE PART LIST OF AMTH-V120-60-CLASSIC TEA HARVESTER

Sl. No.	Part No.	Description
1	AMTH-V120-60 CL01	Screw
2	AMTH-V120-60 CL02	inlet wind net
3	AMTH-V120-60 CL03	Screw
4	AMTH-V120-60 CL04	Fan cover(Upper)
5	AMTH-V120-60 CL05	Fan
6	AMTH-V120-60 CL06	Fan cover Lower pressing plate
7	AMTH-V120-60 CL07	Fan cover (Lower)
8	AMTH-V120-60 CL08	Nut
9	AMTH-V120-60 CL09	Fan seat
10	AMTH-V120-60 CL10	Square shaft joint
11	AMTH-V120-60 CL11	Spacer
12	AMTH-V120-60 CL12	Drive Bevel Gear
13	AMTH-V120-60 CL13	Nut
14	AMTH-V120-60 CL14	Rotatory seat
15	AMTH-V120-60 CL15	Bearing
16	AMTH-V120-60 CL16	driven bevel Gear
17	AMTH-V120-60 CL17	Gearbox
18	AMTH-V120-60 CL18	Bearing
19	AMTH-V120-60 CL19	Lower gear shaft
20	AMTH-V120-60 CL20	Left hand grip
21	AMTH-V120-60 CL21	Butterfly screw
22	AMTH-V120-60 CL22	Throttle cable
23	AMTH-V120-60 CL23	Accelator Switch
24	AMTH-V120-60 CL24	Stop switch cable
25	AMTH-V120-60 CL25	Left Handle Seat
26	AMTH-V120-60 CL26	Handle pressure plate

SPARE PART LIST OF AMTH-V120-60-CLASSIC TEA HARVESTER

Sl. No.	Part No.	Description
27	AMTH-V120-60 CL27	Screw
28	AMTH-V120-60 CL28	screw
29	AMTH-V120-60 CL29	Gear case cover
30	AMTH-V120-60 CL30	Bearing
31	AMTH-V120-60 CL31	Bearing
32	AMTH-V120-60 CL32	Anti friction plate
33	AMTH-V120-60 CL33	Connecting rod
34	AMTH-V120-60 CL34	Bearing
35	AMTH-V120-60 CL35	Big gear
36	AMTH-V120-60 CL36	Screw
37	AMTH-V120-60 CL37	Wool Felt
38	AMTH-V120-60 CL38	Balde fixture Block
39	AMTH-V120-60 CL39	Screw
40	AMTH-V120-60 CL40	screw
41	AMTH-V120-60 CL41	Fan Axis
42	AMTH-V120-60 CL42	Screw
43	AMTH-V120-60 CL43	Bearing
44	AMTH-V120-60 CL44	Bearing
45	AMTH-V120-60 CL45	Bearing
46	AMTH-V120-60 CL46	Screw
47	AMTH-V120-60 CL47	Mangenesse Steel gasket
48	AMTH-V120-60 CL48	Balde Screw
49	AMTH-V120-60 CL49	Balde
50	AMTH-V120-60 CL50	Tea bag hook
51	AMTH-V120-60 CL51	Clutch seat
52	AMTH-V120-60 CL52	Right handle

SPARE PART LIST OF AMTH-V120-60-CLASSIC TEA HARVESTER

Sl. No.	Part No.	Description
53	AMTH-V120-60 CL53	Right handle cover
54	AMTH-V120-60 CL54	Screw
55	AMTH-V120-60 CL55	Nut
56	AMTH-V120-60 CL56	Blade cover
57	AMTH-V120-60 CL57	Fixed Bayonet lock
58	AMTH-V120-60 CL58	Balde Screw
59	AMTH-V120-60 CL59	Drive soft shaft
60	AMTH-V120-60 CL60	Drive soft Hose
61	AMTH-V120-60 CL61	Screw
62	AMTH-V120-60 CL62	Bearing
63	AMTH-V120-60 CL63	Circlip
64	AMTH-V120-60 CL64	Clutch disc
65	AMTH-V120-60 CL65	Screw
66	AMTH-V120-60 CL66	Screw
67	AMTH-V120-60 CL67	Self locking nut
68	AMTH-V120-60 CL68	Collecting plate
69	AMTH-V120-60 CL69	Blade press Plate
70	AMTH-V120-60 CL70	Self locking nut
71	AMTH-V120-60 CL71	Slider
72	AMTH-V120-60 CL72	Screw
73	AMTH-V120-60 CL73	Blade support -Right
74	AMTH-V120-60 CL74	Slide Support plate-right
75	AMTH-V120-60 CL75	Screw
76	AMTH-V120-60 CL76	Self locking nut
77	AMTH-V120-60 CL77	Bag hook
78	AMTH-V120-60 CL78	Self tapping screw

SPARE PART LIST OF AMTH-V120-60-CLASSIC TEA HARVESTER

Sl. No.	Part No.	Description
79	AMTH-V120-60 CL79	Wind pipe End cap
80	AMTH-V120-60 CL80	Wind pipe
81	AMTH-V120-60 CL81	Screw
82	AMTH-V120-60 CL82	Backpack Frame
83	AMTH-V120-60 CL83	Screw
84	AMTH-V120-60 CL84	Back Cushion
85	AMTH-V120-60 CL85	Straps
86	AMTH-V120-60 CL86	Damping Spring
87	AMTH-V120-60 CL87	Nut
88	AMTH-V120-60 CL88	Flat gasket
89	AMTH-V120-60 CL89	Triangle plate
90	AMTH-V120-60 CL90	Screw
91	AMTH-V120-60 CL91	Bearing
92	AMTH-V120-60 CL92	Screw
93	AMTH-V120-60 CL93	Engine bracket
94	AMTH-V120-60 CL94	Screw
95	AMTH-V120-60 CL95	Screw

Warranty Card

CUSTOMER COPY



Purchaser's Name & Address

Product Name

AMTH-V120-60-CLASSIC TEA HARVESTER

Product Serial No.

Invoice / DN No.

Date of Delivery

Dealer's Office Seal

Dealer Sign _____

Customer Sign. _____

I/We accept the terms and conditions of Warranty as in the Warranty Card.

Warranty Card

DEALER'S COPY



Purchaser's Name & Address

Product Name

AMTH-V120-60-CLASSIC TEA HARVESTER

Product Serial No.

Invoice / DN No.

Date of Delivery

Dealer's Office Seal

Dealer Sign _____

Customer Sign. _____

I/We accept the terms and conditions of Warranty as in the Warranty Card.

Warranty Card

COMPANY COPY



Purchaser's Name & Address

Product Name

AMTH-V120-60-CLASSIC TEA HARVESTER

Product Serial No.

Invoice / DN No.

Date of Delivery

Dealer's Office Seal

Dealer Sign _____

Customer Sign. _____

I/We accept the terms and conditions of Warranty as in the Warranty Card.

1. **LIMITED WARRANTY PERIOD** : For a period of six months from the date of Sale / delivery of the product which ever is earlier. 2. **LIMITED WARRANTY OBLIGATION** : Replacement of defective part(s) by authorized dealer are free of charges. If found defective by reasons of defective material / poor workmanship, parts will be replaced and there will be no value re-imbusement. 3. **TERMS & CONDITIONS** : a. Claims under warranty will be accepted on submission of Warranty Card duly filled and stamped by authorized dealer together with the original purchase document. : b. Shipping / transportation / Incidental charges incurred in replacing defective parts under warranty shall be borne by the purchaser.

WARRANTY null & void if

- (i) Lack of maintenance, (ii) Incorrect use of the machine or tampering, (iii) Use of non-genuine spare parts, (iv) Usage of acids, solvents, or any flammable materials, (v) Non-usage of filter water / clear water / soft water & using water above 40°C temperature, (vi) While using the pressure washers to draw water which is contaminated with dust & solvents (eg. paint thinners, gasoline, oil, etc.), (vii) Repair done by unauthorized service people, (viii) Those parts subject to wear & tear due to normal operations and plastic parts, rubber items etc, (ix) Loose connections, faulty electrical fixtures & fluctuations in power supply.
4. Should any failure occur during or after the warranty period, customer does not have the right to interrupt payment / price discount.
5. Incidental or consequential damages like inconvenience commercial loss, loss of tie, mental agony etc.
6. Loss of any nature due to operation or non-operation is not covered under warranty.
7. All free service are at Dealer's service point only.
8. Warranty ceases if service is not done periodically.
9. The attached card should be completed and returned to Ratnagiri Impex Pvt. Ltd. for registration immediately after sale / delivery.
10. The warranty is void unless you register the warranty card with Ratnagiri Impex Pvt. Ltd.
11. The decision of Ratnagiri Impex Pvt. Ltd., in settling the warranty is final in all respects.
12. All disputes are subject to Bangalore Courts Jurisdiction

1. **LIMITED WARRANTY PERIOD** : For a period of six months from the date of Sale / delivery of the product which ever is earlier. 2. **LIMITED WARRANTY OBLIGATION** : Replacement of defective part(s) by authorized dealer are free of charges. If found defective by reasons of defective material / poor workmanship, parts will be replaced and there will be no value re-imbusement. 3. **TERMS & CONDITIONS** : a. Claims under warranty will be accepted on submission of Warranty Card duly filled and stamped by authorized dealer together with the original purchase document. : b. Shipping / transportation / Incidental charges incurred in replacing defective parts under warranty shall be borne by the purchaser.

WARRANTY null & void if

- (i) Lack of maintenance, (ii) Incorrect use of the machine or tampering, (iii) Use of non-genuine spare parts, (iv) Usage of acids, solvents, or any flammable materials, (v) Non-usage of filter water / clear water / soft water & using water above 40°C temperature, (vi) While using the pressure washers to draw water which is contaminated with dust & solvents (eg. paint thinners, gasoline, oil, etc.), (vii) Repair done by unauthorized service people, (viii) Those parts subject to wear & tear due to normal operations and plastic parts, rubber items etc, (ix) Loose connections, faulty electrical fixtures & fluctuations in power supply.
4. Should any failure occur during or after the warranty period, customer does not have the right to interrupt payment / price discount.
5. Incidental or consequential damages like inconvenience commercial loss, loss of tie, mental agony etc.
6. Loss of any nature due to operation or non-operation is not covered under warranty.
7. All free service are at Dealer's service point only.
8. Warranty ceases if service is not done periodically.
9. The attached card should be completed and returned to Ratnagiri Impex Pvt. Ltd. for registration immediately after sale / delivery.
10. The warranty is void unless you register the warranty card with Ratnagiri Impex Pvt. Ltd.
11. The decision of Ratnagiri Impex Pvt. Ltd., in settling the warranty is final in all respects.
12. All disputes are subject to Bangalore Courts Jurisdiction

1. **LIMITED WARRANTY PERIOD** : For a period of six months from the date of Sale / delivery of the product which ever is earlier. 2. **LIMITED WARRANTY OBLIGATION** : Replacement of defective part(s) by authorized dealer are free of charges. If found defective by reasons of defective material / poor workmanship, parts will be replaced and there will be no value re-imbusement. 3. **TERMS & CONDITIONS** : a. Claims under warranty will be accepted on submission of Warranty Card duly filled and stamped by authorized dealer together with the original purchase document. : b. Shipping / transportation / Incidental charges incurred in replacing defective parts under warranty shall be borne by the purchaser.

WARRANTY null & void if

- (i) Lack of maintenance, (ii) Incorrect use of the machine or tampering, (iii) Use of non-genuine spare parts, (iv) Usage of acids, solvents, or any flammable materials, (v) Non-usage of filter water / clear water / soft water & using water above 40°C temperature, (vi) While using the pressure washers to draw water which is contaminated with dust & solvents (eg. paint thinners, gasoline, oil, etc.), (vii) Repair done by unauthorized service people, (viii) Those parts subject to wear & tear due to normal operations and plastic parts, rubber items etc, (ix) Loose connections, faulty electrical fixtures & fluctuations in power supply.
4. Should any failure occur during or after the warranty period, customer does not have the right to interrupt payment / price discount.
5. Incidental or consequential damages like inconvenience commercial loss, loss of tie, mental agony etc.
6. Loss of any nature due to operation or non-operation is not covered under warranty.
7. All free service are at Dealer's service point only.
8. Warranty ceases if service is not done periodically.
9. The attached card should be completed and returned to Ratnagiri Impex Pvt. Ltd. for registration immediately after sale / delivery.
10. The warranty is void unless you register the warranty card with Ratnagiri Impex Pvt. Ltd.
11. The decision of Ratnagiri Impex Pvt. Ltd., in settling the warranty is final in all respects.
12. All disputes are subject to Bangalore Courts Jurisdiction



1st Free Service Coupon

ISO 9001:2015
CERTIFIED COMPANY

FREE SERVICE COUPON (30 Days / 30 hrs (Which ever is earlier))

Model

AMTH-V120-60-CLASSIC TEA HARVESTER

PDI Date

Service No.

Dealer's Office Seal

Dealer Signature.....

Conditions: Operations listed have been performed to my entire satisfaction without any labour charges. Only consumables were charged.

Serial Number

Purchase bill no.

Date

Operations:

- Check and Test the Fuel Mixture.
- Check and Clean the Air Filter
- Check, Clean and Adjust the Spark plug
- Check and Adjust the Carburetor Tuning
- Check and Sharpen the cutting Tools
- Start and Check the Noise, Vibration, Loosen / Fasteners etc.
- Product familiarization on Usage
- Routine maintenance and Storage

WARRANTY AND FREE SERVICE COUPON



agriculture, horticulture, sericulture, plantation, forestry, garden, health care



2nd Free Service Coupon

ISO 9001:2015
CERTIFIED COMPANY

FREE SERVICE COUPON (60 Days / 60 hrs (Which ever is earlier))

Model

AMTH-V120-60-CLASSIC TEA HARVESTER

PDI Date

Service No.

Dealer's Office Seal

Dealer Signature.....

Conditions: Operations listed have been performed to my entire satisfaction without any labour charges. Only consumables were charged.

Serial Number

Purchase bill no.

Date

Operations:

- Check and Test the Fuel Mixture.
- Check and Clean the Air Filter
- Check, Clean and Adjust the Spark plug
- Check and Adjust the Carburetor Tuning
- Check and Sharpen the cutting Tools
- Start and Check the Noise, Vibration, Loosen / Fasteners etc.
- Product familiarization on Usage
- Routine maintenance and Storage

WARRANTY AND FREE SERVICE COUPON



agriculture, horticulture, sericulture, plantation, forestry, garden, health care



3rd Free Service Coupon

ISO 9001:2015
CERTIFIED COMPANY

FREE SERVICE COUPON (90 Days / 120hrs (Which ever is earlier))

Model

AMTH-V120-60-CLASSIC TEA HARVESTER

PDI Date

Service No.

Dealer's Office Seal

Dealer Signature.....

Conditions: Operations listed have been performed to my entire satisfaction without any labour charges. Only consumables were charged.

Serial Number

Purchase bill no.

Date

Operations:

- Check and Test the Fuel Mixture.
- Check and Clean the Air Filter
- Check, Clean and Adjust the Spark plug
- Check and Adjust the Carburetor Tuning
- Check and Sharpen the cutting Tools
- Start and Check the Noise, Vibration, Loosen / Fasteners etc.
- Product familiarization on Usage
- Routine maintenance and Storage

WARRANTY AND FREE SERVICE COUPON



agriculture, horticulture, sericulture, plantation, forestry, garden, health care



AGRI MART

FARM EQUIPMENT GREEN CARE SERVICES



Do's & Don'ts

- Always read the instruction manual supplied along with the equipments and understand the correct installation and operating procedures before attempting to use the equipments.
- It is important to use the personal protection equipments such as head helmet with visor, ear defenders, goggles, safety gloves, cut resistant shoes, trousers and jackets while operating potentially dangerous machines.
- Avoid untrained persons using the equipments. Children must not be allowed to handle these equipments.
- Always use genuine spares and accessories in repairs and usage to derive maximum life of the equipments.
- Always keep the equipments in good working condition to minimize loss of output as well as to reduce the pollution and save the environment.
- Do not use the machine within range of persons unless they wear protective clothing.
- Do not operate the machine when fatigued or under the influence of alcohol or drugs.
- For more query kindly contact for our Service Center/Dealer/ franchise



Small and Timely Maintenance - Big Savings

MULTIPLY PROFITS

WITH OUR MULTI CROP, MULTI PURPOSE EQUIPMENTS



Maximum Power - Super Economy
RANGE OF PRODUCTS



BATTERY /
MANUAL
SPRAYER



PORTABLE
POWER
SPRAYER



KNAPSACK
POWER
SPRAYER



ROTARY
TILLER



CHAFF
CUTTER



TEA
PRUNER



FOGGER



POWER
WEEDER



CHAINSAW



ROTARY
TILLER



LAWN
MOWER



HIGH
PRESSURE
WASHER



EARTH
AUGER



RIDE ON
MOWER



our power, your passion
RANGE OF PRODUCTS



Advanced Technology

Advanced Technology

RANGE OF PRODUCTS



BRUSH CUTTER
- PUSH TYPE



BRUSH CUTTER -
BACK PACK



BRUSH CUTTER -
MULTI TOOL



POLE PRUNER



BLOWER
BACK PACK



LAWN MOWER



BRUSH
CUTTER



BACK PACK
BC



TILLER



FOGGER



EARTH
AUGER



Green Panther®

RANGE OF PRODUCTS

OUR RETAIL FORMATS



IMPORTERS & MARKETING BY:

Ratnagiri Impex Pvt. Ltd.

Annapurna House, # 1/1G,

7th Cross New Guddadahalli,

Mysore Road Bangalore - 560 026, India

Ph: 080-26985100/1/2

Email: info@ratnagiriimpex.com



TOLL FREE :
1800-425-3036

www.ratnagiriimpex.com

www.agrimart.in



ratnagiri
impex
BRINGING YOU THE FUTURE... NOW

An ISO 9001:2015 Certified Company

agriculture | horticulture | sericulture | plantations | forestry | garden | health care