

# USER MANUAL

## USER MANUAL ENGINE - AM178FD

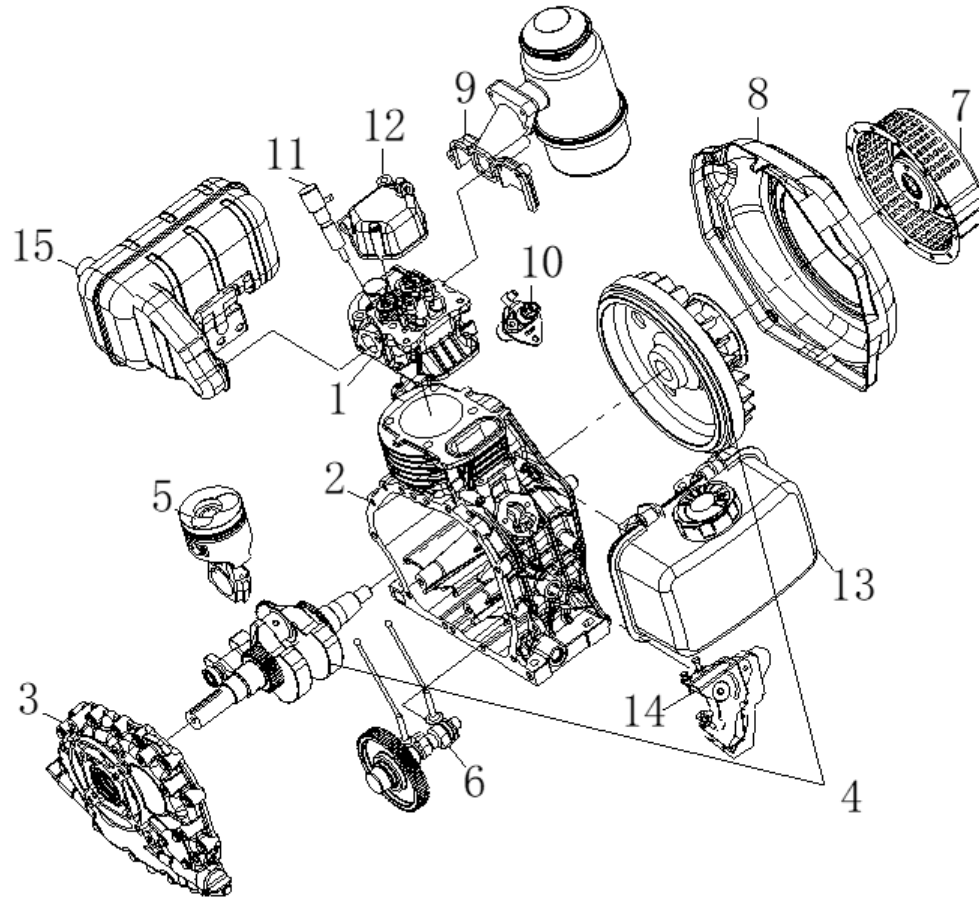

# ENGINE ASSY - A



SL NO	PART NO	DESCRIPTION
1	AM-178FSD-EA01	Cylinder Head Assy
2	AM-178FSD-EA02	Crankcase Assy
3	AM-178FSD-EA03	Crankcase Cover Assy
4	AM-178FSD-EA04	Crank-Fly Wheel Assy
5	AM-178FSD-EA05	Piston-Connecting Rod Assy
6	AM-178FSD-EA06	Camshaft Assy
7	AM-178FSD-EA07	Start Cover Assy
8	AM-178FSD-EA08	Wind Scooper Assy
9	AM-178FSD-EA09	Inlet Assy
10	AM-178FSD-EA10	Oil Pump Assy
11	AM-178FSD-EA11	Fuel Injection Assy
12	AM-178FSD-EA12	Bonnet Assy
13	AM-178FSD-EA13	Fuel Oil Assy
14	AM-178FSD-EA14	Throttle Control Assy
15	AM-178FSD-EA15	Exhaust Assy

# CYLINDER HEAD ASSY - B

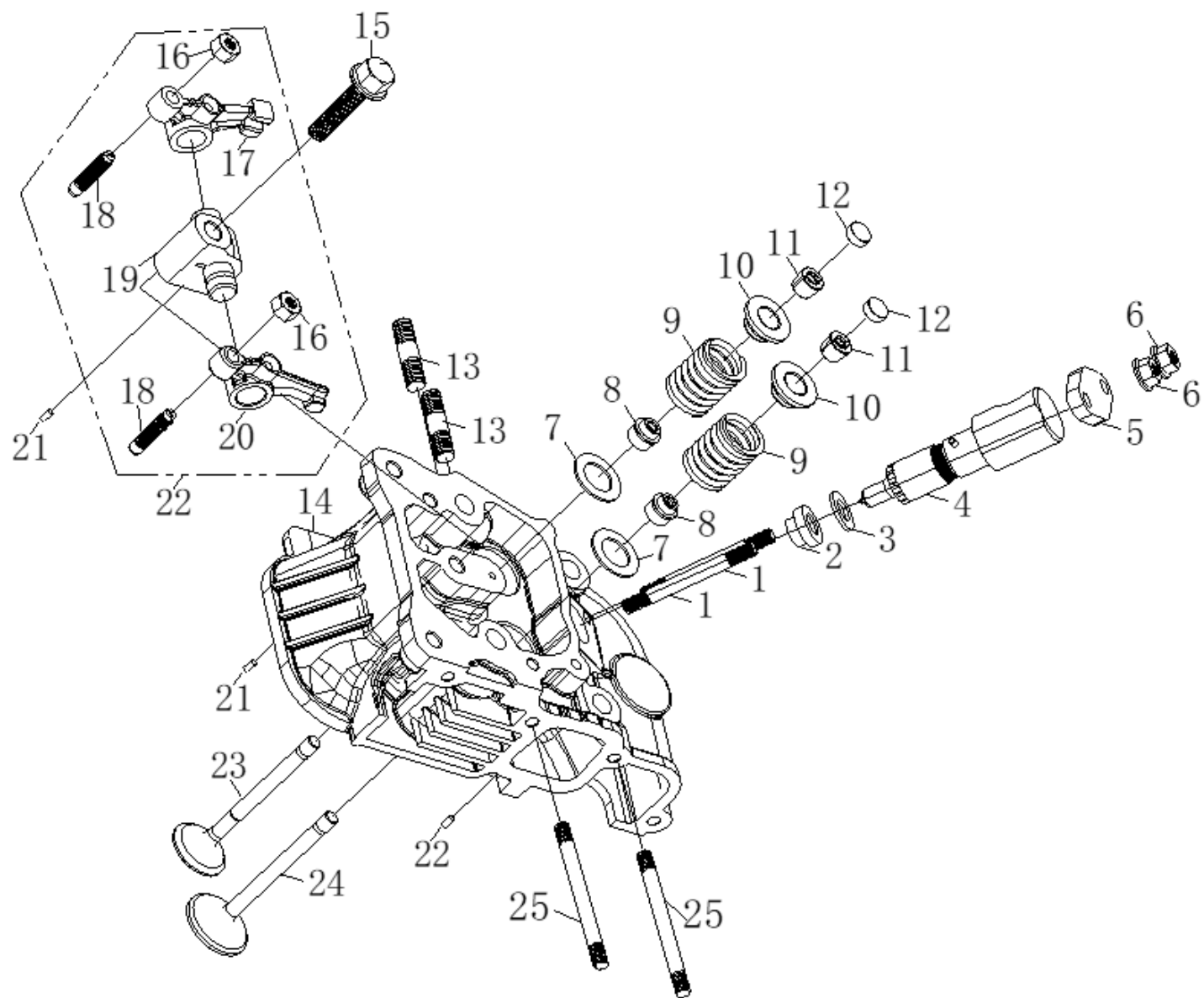

SL NO	PART NO	DESCRIPTION	SL NO	PART NO	DESCRIPTION
1	AM-178FSD-EB01	Stud Bolt	17	AM-178FSD-EB17	Valve Exhaust Arm
2	AM-178FSD-EB02	NA	18	AM-178FSD-EB18	Valve Screw
3	AM-178FSD-EB03	NA	19	AM-178FSD-EB19	Arm Base
4	AM-178FSD-EB04	NA	20	AM-178FSD-EB20	Valve Inlet Arm
5	AM-178FSD-EB05	Fuel Injection Clamp	21	AM-178FSD-EB21	Pin
6	AM-178FSD-EB06	Flange Nut	22	AM-178FSD-EB22	Arm Assy
7	AM-178FSD-EB07	Valve Spring Washer	23	AM-178FSD-EB23	Exhaust Valve
8	AM-178FSD-EB08	Valve Seal	24	AM-178FSD-EB24	Inlet Valve
9	AM-178FSD-EB09	Vale Spring			
10	AM-178FSD-EB10	Rock Arm Assy			
11	AM-178FSD-EB11	Cotter			
12	AM-178FSD-EB12	Valve Adjusting Plate			
13	AM-178FSD-EB13	Stud Bolt			
14	AM-178FSD-EB14	Cylinder Head Assy			
15	AM-178FSD-EB15	Flange Bolt			
16	AM-178FSD-EB16	Lock Nut			

# CRANKCASE ASSY - C

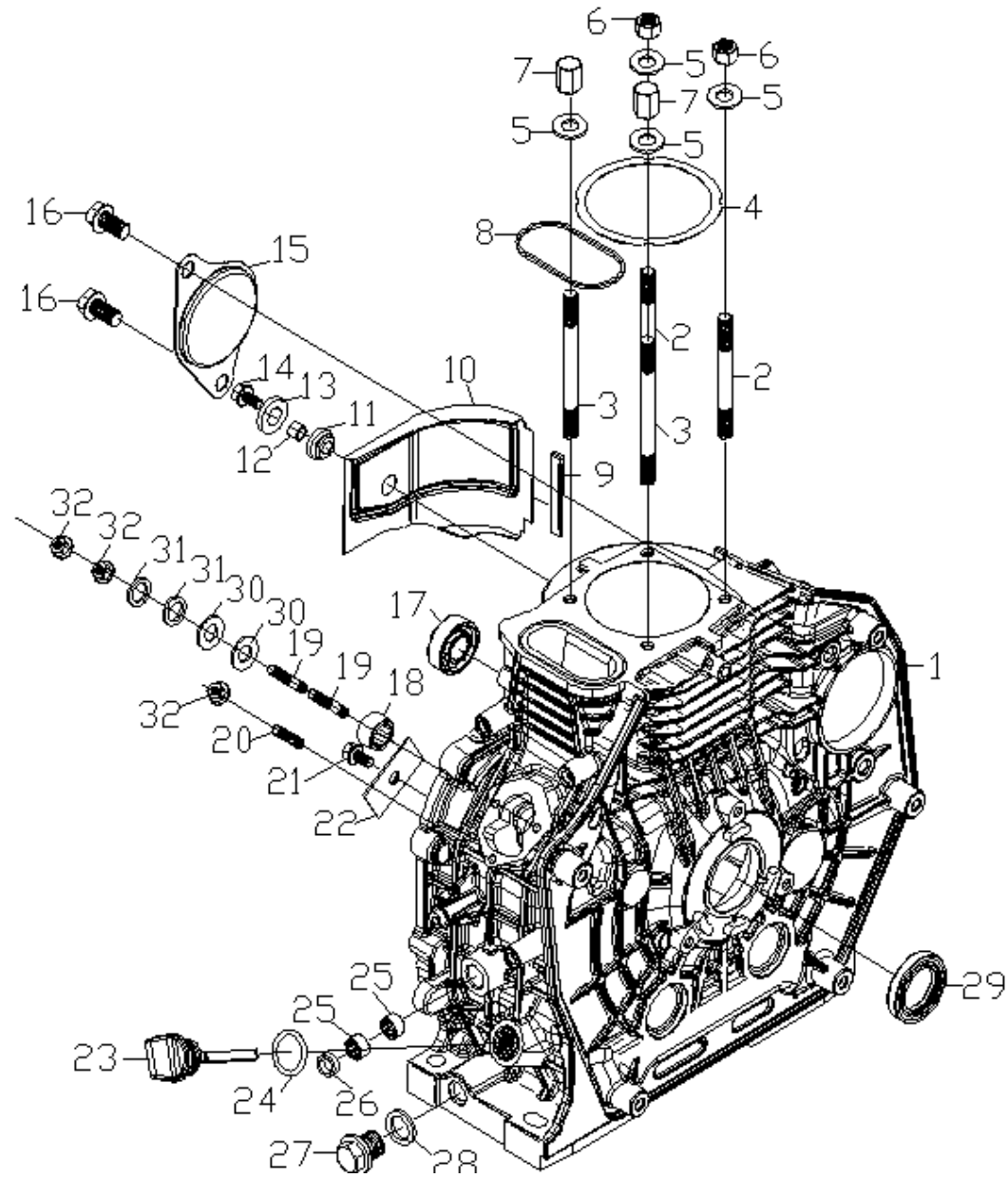

SL NO	PART NO	DESCRIPTION	SL NO	PART NO	DESCRIPTION
1	AM-178FSD-EC01	Crankcase Comp	17	AM-178FSD-EC17	Ball Bearing
2	AM-178FSD-EC02	Cylinder Head Stud	18	AM-178FSD-EC18	Needle Bearing
3	AM-178FSD-EC03	Cylinder Head Stud	19	AM-178FSD-EC19	Bolt Stud
4	AM-178FSD-EC04	Cylinder Head Shim	20	AM-178FSD-EC20	Bolt Stud
5	AM-178FSD-EC05	Washer	21	AM-178FSD-EC21	Bolt
6	AM-178FSD-EC06	Cylinder Head Nut	22	AM-178FSD-EC22	Retainer
7	AM-178FSD-EC07	Cylinder Head Nut Thick	23	AM-178FSD-EC23	Oil Filler Gap
8	AM-178FSD-EC08	Rectangle Seal Ring	24	AM-178FSD-EC24	O-Ring
9	AM-178FSD-EC09	Wind Guide Plate Cushion	25	AM-178FSD-EC25	Needle Bearing
10	AM-178FSD-EC10	Wind Guide Plate	26	AM-178FSD-EC26	Oil Seal
11	AM-178FSD-EC11	Vibration Isolation Cushion Block	27	AM-178FSD-EC27	Drain Plug
12	AM-178FSD-EC12	Lining	28	AM-178FSD-EC28	Oil Plug Seal
13	AM-178FSD-EC13	Washer	29	AM-178FSD-EC29	Oil Seal
14	AM-178FSD-EC14	Flange Bolt	30	AM-178FSD-EC30	Washer
15	AM-178FSD-EC15	Starter Seat Cover	31	AM-178FSD-EC31	Spring Washer
16	AM-178FSD-EC16	Flange Bolt	32	AM-178FSD-EC32	Flange Bolt

# CRANKCASE COVER ASSY - D

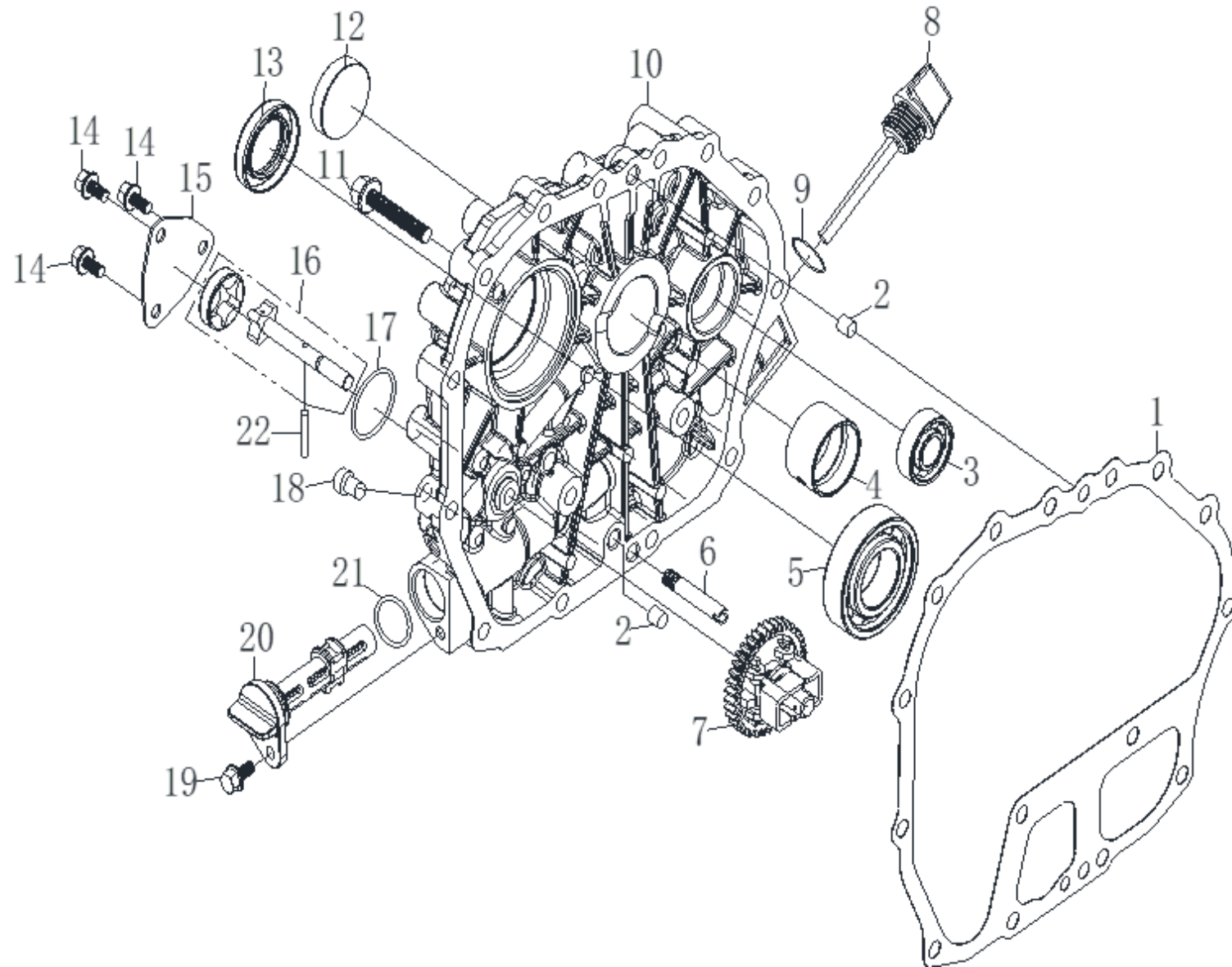

SL NO	PART NO	DESCRIPTION	SL NO	PART NO	DESCRIPTION
1	AM-178FSD-ED01	Case Cover Gasket	17	AM-178FSD-ED17	Sealing Ring
2	AM-178FSD-ED02	Pin	18	AM-178FSD-ED18	Block Bolt
3	AM-178FSD-ED03	Bearing	19	AM-178FSD-ED19	Flange Bolt
4	AM-178FSD-ED04	Main Bearing	20	AM-178FSD-ED20	Engine Oil Filter Element
5	AM-178FSD-ED05	Ball Bearing	21	AM-178FSD-ED21	Seal Ring
6	AM-178FSD-ED06	Oil Indicator	22	AM-178FSD-ED22	Pin
7	AM-178FSD-ED07	Governor Kit Comp			
8	AM-178FSD-ED08	Dipstick			
9	AM-178FSD-ED09	O- Ring			
10	AM-178FSD-ED10	Crankcase Cover			
11	AM-178FSD-ED11	Flange Bolt			
12	AM-178FSD-ED12	Oil passage plug			
13	AM-178FSD-ED13	Oil Seal			
14	AM-178FSD-ED14	Flange Bolt			
15	AM-178FSD-ED15	Oil Pump Cover			
16	AM-178FSD-ED16	Oil Pump Assy			

# CRANK-FLY WHEEL ASSY - E

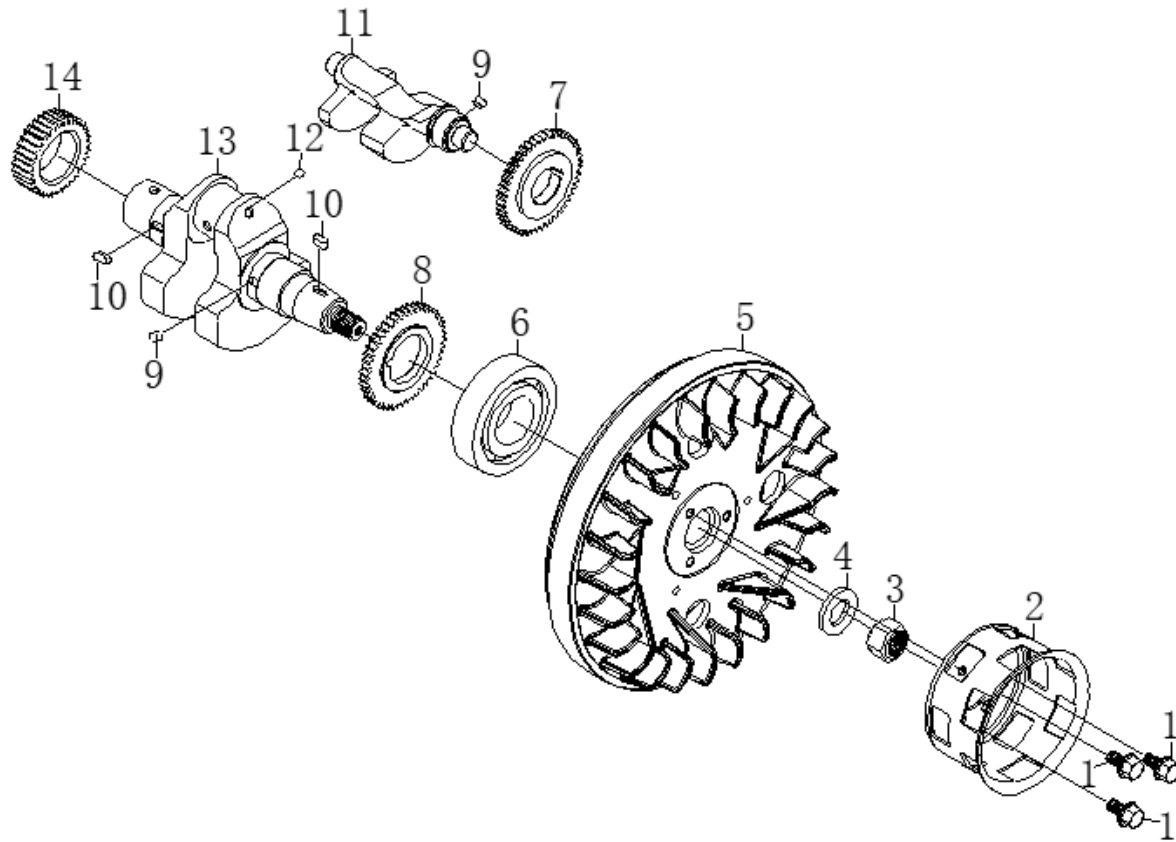

SL NO	PART NO	DESCRIPTION
1	AM-178FSD-EE01	Flange Bolt
2	AM-178FSD-EE02	Starter Pulley
3	AM-178FSD-EE03	Flange Nut
4	AM-178FSD-EE04	Washer
5	AM-178FSD-EE05	Fly Wheel
6	AM-178FSD-EE06	Ball Bearing
7	AM-178FSD-EE07	Timing Gear Of Balance Shaft
8	AM-178FSD-EE08	Drive Gear Of Balance Shsft
9	AM-178FSD-EE09	Key
10	AM-178FSD-EE10	Key
11	AM-178FSD-EE11	Balancer Shaft
12	AM-178FSD-EE12	Steel Ball
13	AM-178FSD-EE13	Crank Shaft Assy
14	AM-178FSD-EE14	Crankshaft Timing Gear

# PISTON-CONNECTING ROD ASSY -F

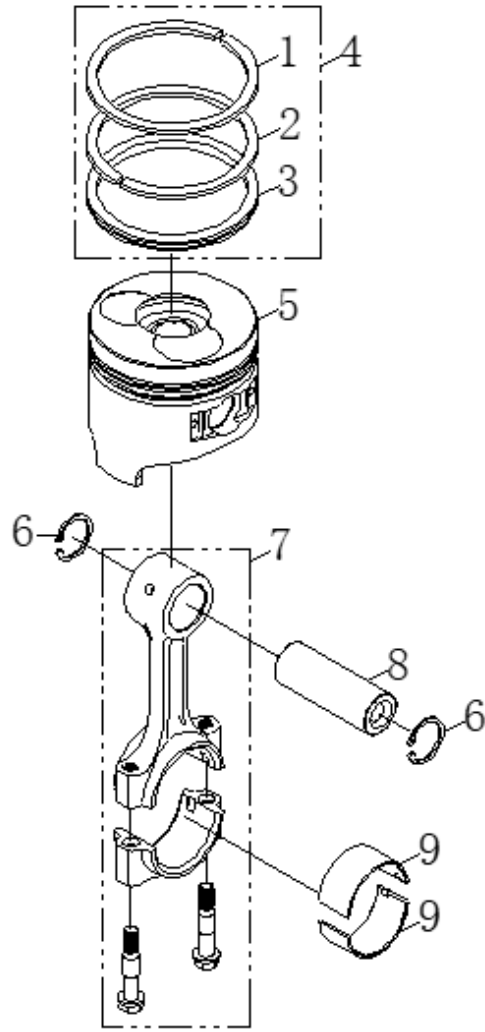

SL NO	PART NO	DESCRIPTION
1	AM-178FSD-EF01	N A
2	AM-178FSD-EF02	NA
3	AM-178FSD-EF03	NA
4	AM-178FSD-EF04	Piston Ring Assy
5	AM-178FSD-EF05	Piston
6	AM-178FSD-EF06	Piston Pin Clip
7	AM-178FSD-EF07	Connecting Rod Assy
8	AM-178FSD-EF08	Piston Pin
9	AM-178FSD-EF09	Crank Pin Bearing



# START COVER ASSY - H

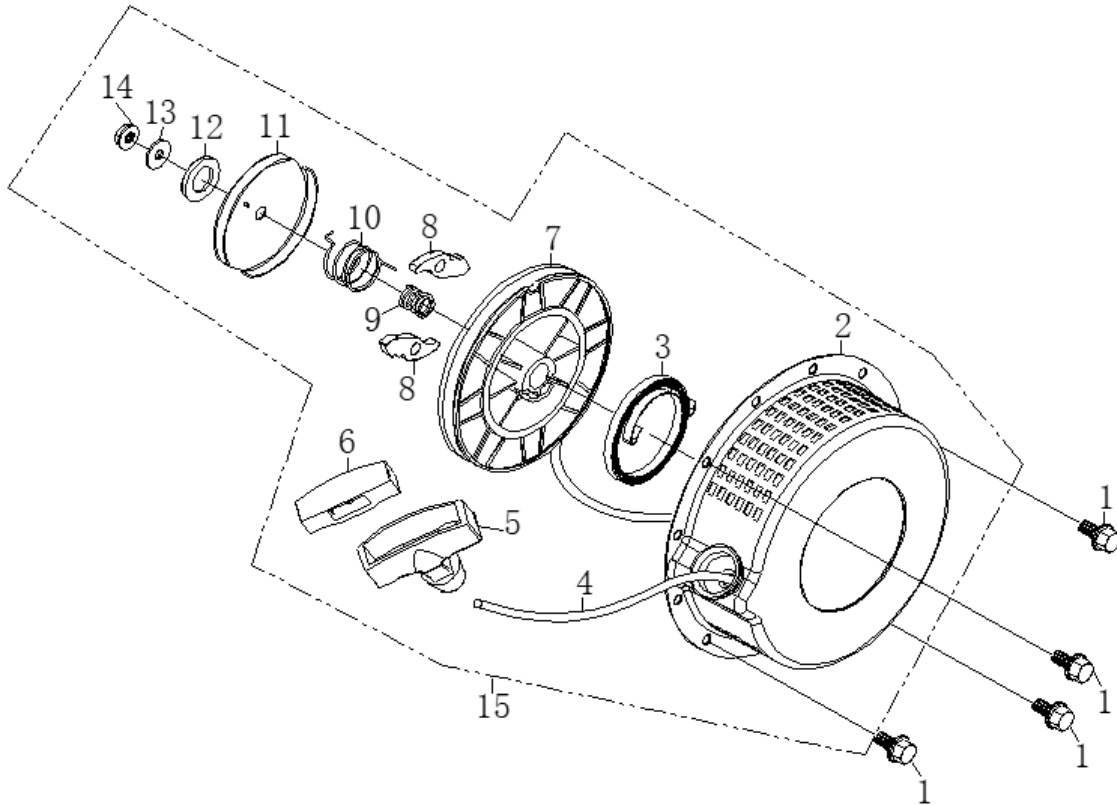

SL NO	PART NO	DESCRIPTION
1	AM-178FSD-EH01	Flange Bolt
2	AM-178FSD-EH02	Recoil Stater Cover Comp
3	AM-178FSD-EH03	Spiral Spring
4	AM-178FSD-EH04	Recoil Starter Rope
5	AM-178FSD-EH05	Starter Handle
6	AM-178FSD-EH06	Starter Handle Cover
7	AM-178FSD-EH07	Starter Reel
8	AM-178FSD-EH08	Starter Patchet
9	AM-178FSD-EH09	Compress Spring
10	AM-178FSD-EH10	Return Spring
11	AM-178FSD-EH11	Spring Cover
12	AM-178FSD-EH12	Rubber Washer
13	AM-178FSD-EH13	Washer
14	AM-178FSD-EH14	Nut
15	AM-178FSD-EH15	Handle Starter

# WIND SCOOPER ASSY - J

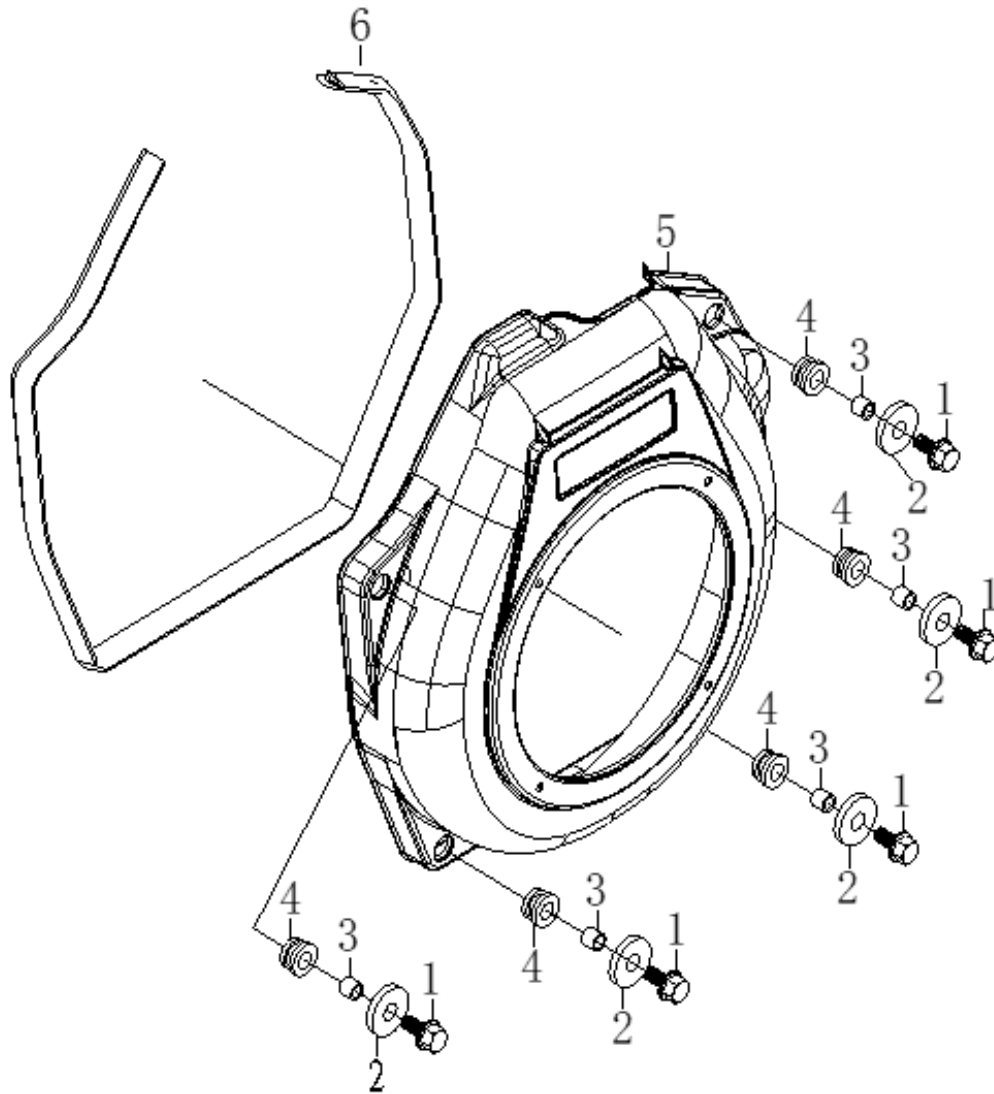

SL NO	PART NO	DESCRIPTION
1	AM-178FSD-EJ01	Bolt
2	AM-178FSD-EJ02	Washer
3	AM-178FSD-EJ03	Collar
4	AM-178FSD-EJ04	Shock Absorber
5	AM-178FSD-EJ05	Wind Scooper Assy
6	AM-178FSD-EJ06	Shock Absorber Seat

# AIR FILTER ASSY - K

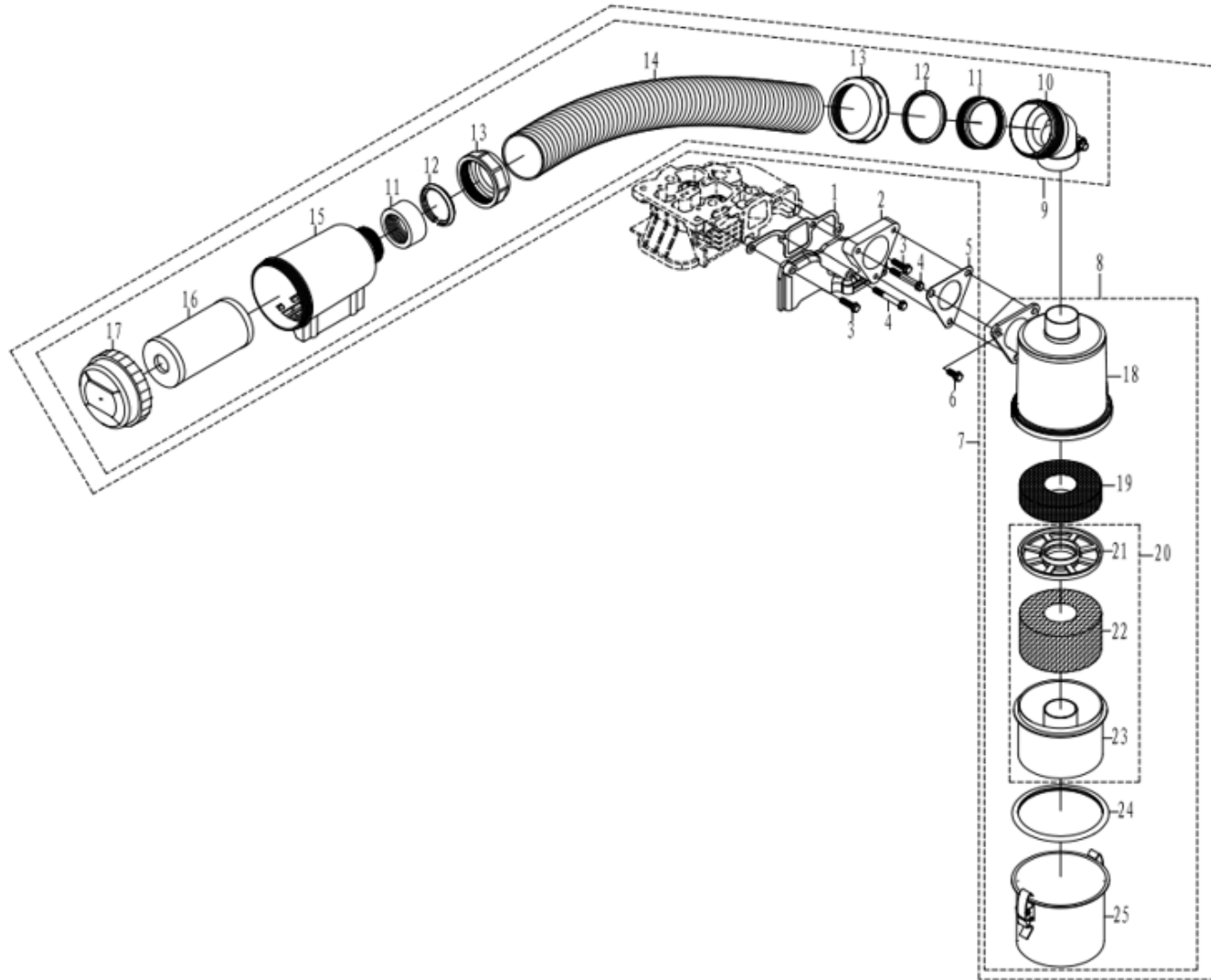

SL NO	PART NO	DESCRIPTION	SL NO	PART NO	DESCRIPTION
1	AM-178FSD-EK01	Intake Pipe Gasket	17	AM-178FSD-EK17	Air filter cover assembly
2	AM-178FSD-EK02	Intake Pipe	18	AM-178FSD-EK18	Filter Case Cover
3	AM-178FSD-EK03	Flange Bolt	19	AM-178FSD-EK19	Foam Filter
4	AM-178FSD-EK04	Flange Bolt	20	AM-178FSD-EK20	Air filter element assembly
5	AM-178FSD-EK05	Air Cleaner Gasket	21	AM-178FSD-EK21	Steel Wire Filter
6	AM-178FSD-EK06	Air Filter Connecting Disc	22	AM-178FSD-EK22	Filter Case
7	AM-178FSD-EK07	Air Cleaner Assy	23	AM-178FSD-EK23	Air Filter Sump
8	AM-178FSD-EK08	air filter assembly	24	AM-178FSD-EK24	Filter box sealing ring
9	AM-178FSD-EK09	air filter assembly	25	AM-178FSD-EK25	Air filter oil filter oil cup
10	AM-178FSD-EK10	Air filter intake pipe joint			
11	AM-178FSD-EK11	Intake pipe joint gasket			
12	AM-178FSD-EK12	Intake pipe limit collar			
13	AM-178FSD-EK13	Intake pipe thread ring			
14	AM-178FSD-EK14	Intake pipe			
15	AM-178FSD-EK15	Air filter housing			
16	AM-178FSD-EK16	Air filter element assembly			

# FUEL PUMP ASSY - L

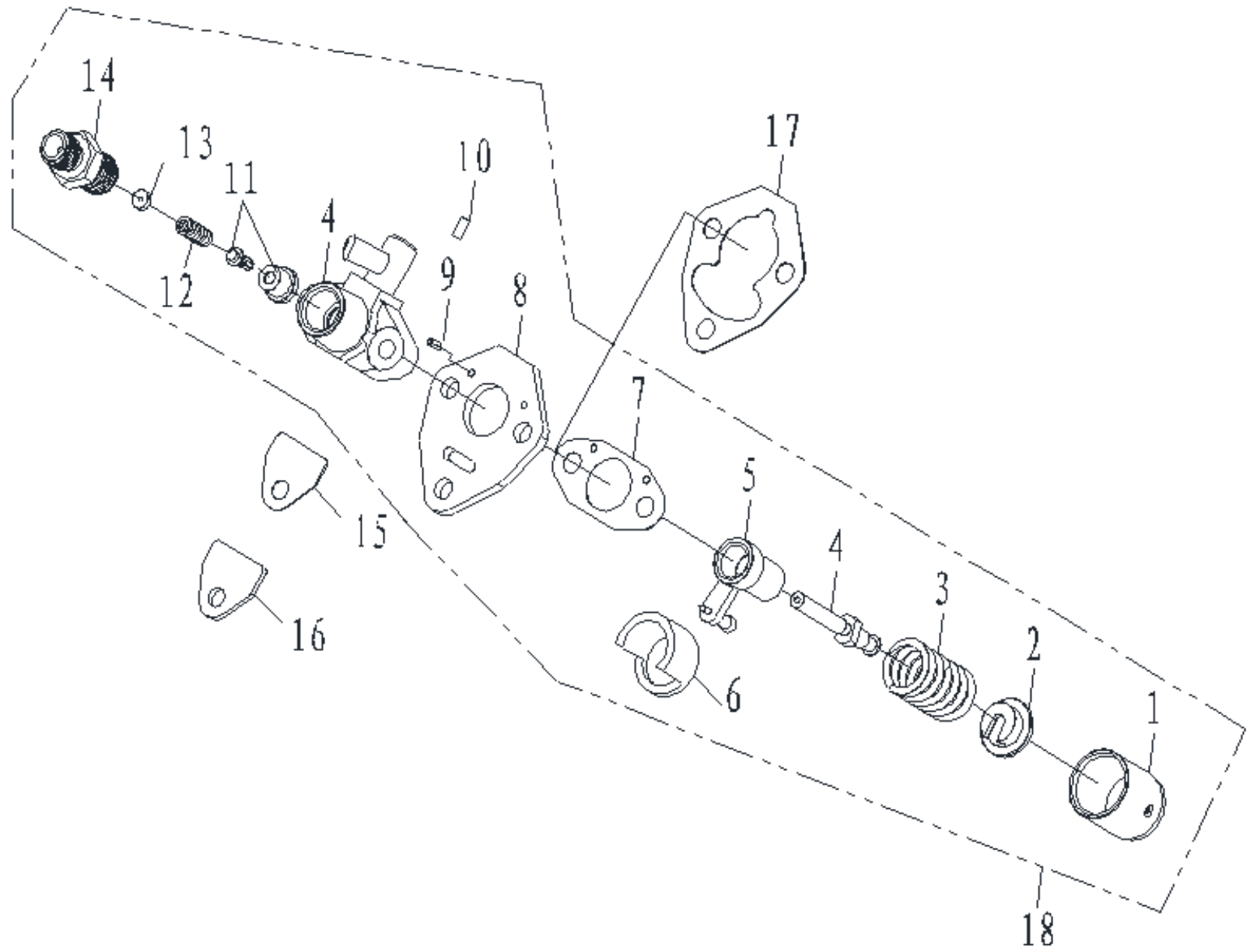

SL NO	PART NO	DESCRIPTION	SL NO	PART NO	DESCRIPTION
1	AM-178FSD-EL01	Tappet	17	AM-178FSD-EL17	Fuel Pump Gasket
2	AM-178FSD-EL02	Spring Holder	18	AM-178FSD-EL18	Fuel Pump Cover
3	AM-178FSD-EL03	Spring			
4	AM-178FSD-EL04	Plunger			
5	AM-178FSD-EL05	Fuel Limiting Sheath Weldmenl Assy			
6	AM-178FSD-EL06	Support			
7	AM-178FSD-EL07	Fuel Pump Gasket			
8	AM-178FSD-EL08	Washer			
9	AM-178FSD-EL09	Fip Connecting Plate			
10	AM-178FSD-EL10	Pi			
11	AM-178FSD-EL11	Oil outlet			
12	AM-178FSD-EL12	Fuel Delivery Valve Core			
13	AM-178FSD-EL13	Fuel Delivery Valve Seat			
14	AM-178FSD-EL14	Fuel Delhrery Valve Spring			
15	AM-178FSD-EL15	Fuel Delhrery Washer			
16	AM-178FSD-EL16	Fuel Delvery Valve Forcing Holder			

# FUEL INJECTION ASSY - M

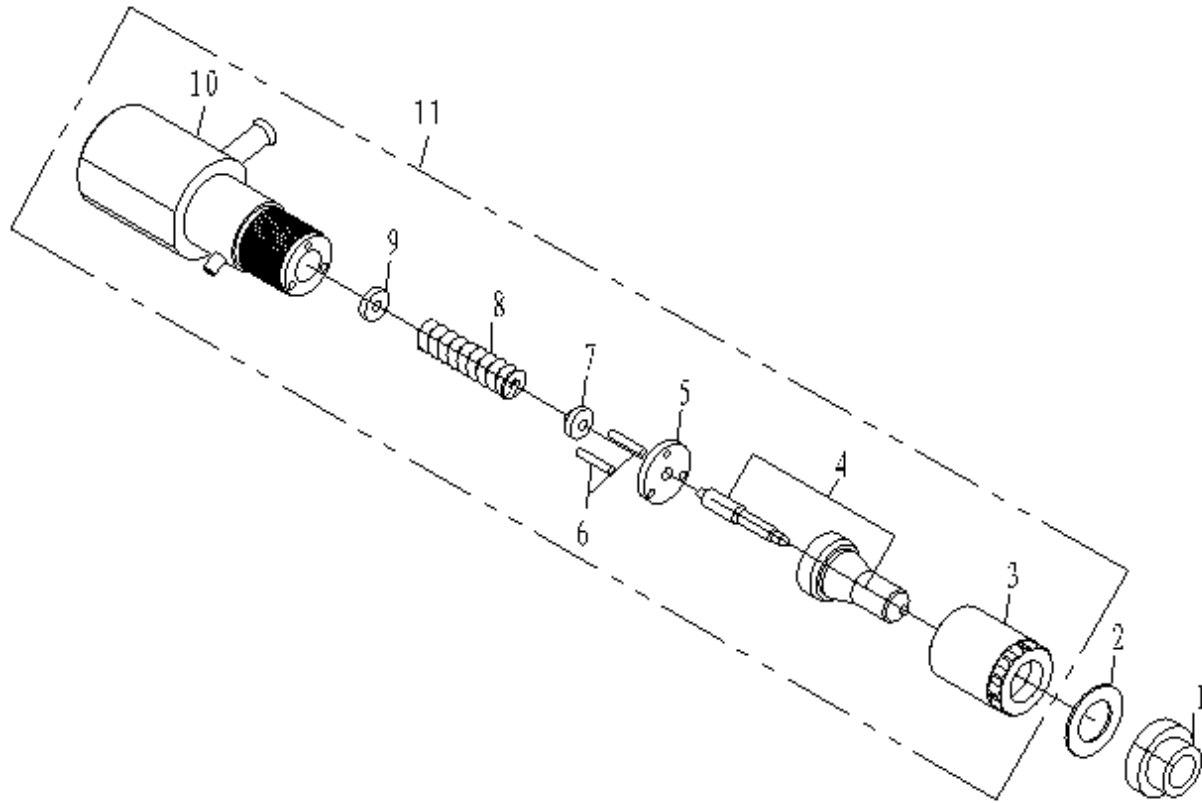

SL NO	PART NO	DESCRIPTION	SL NO	PART NO	DESCRIPTION
1	AM-178FSD-EM01	Adjusting Gasket Cover	7	AM-178FSD-EM07	Mandril
2	AM-178FSD-EM02	Adjusting Gasket	8	AM-178FSD-EM08	Volt-Adjustment Spring
3	AM-178FSD-EM03	fuel injector cap	9	AM-178FSD-EM09	Washer
4	AM-178FSD-EM04	Injector coupler	10	AM-178FSD-EM10	Fuel Injection Valve Block
5	AM-178FSD-EM05	Intermediate Block	11	AM-178FSD-EM11	Fuel Injection Assy
6	AM-178FSD-EM06	Locating Pin			

# BONNET ASSY- N

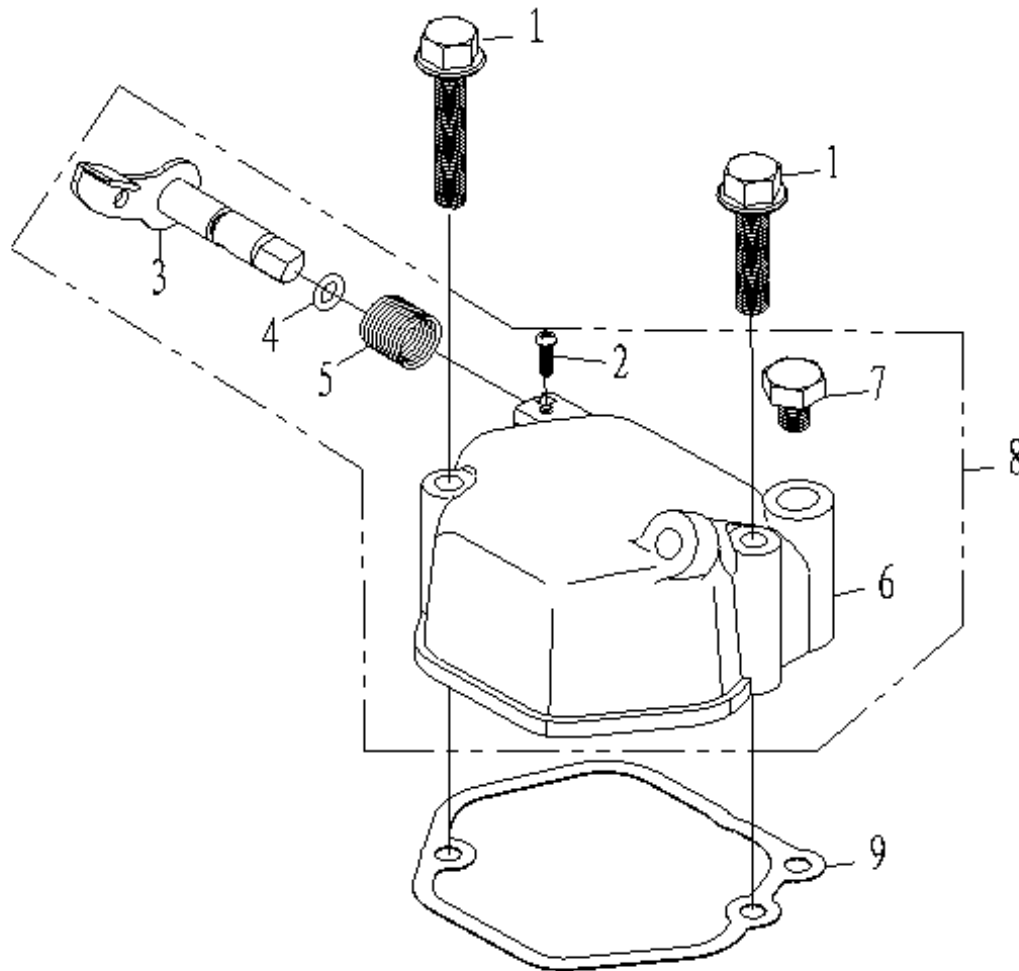

SL NO	PART NO	DESCRIPTION
1	AM-178FSD-EN01	Flange Bolt
2	AM-178FSD-EN02	Roller Install Bolt
3	AM-178FSD-EN03	Decompress Roller
4	AM-178FSD-EN04	O-ring rubber seal
5	AM-178FSD-EN05	Decompress Spring
6	AM-178FSD-EN06	Bonnet
7	AM-178FSD-EN07	Bolt
8	AM-178FSD-EN08	Bonnet Assy
9	AM-178FSD-EN09	Bonner Gasket

# FUEL OIL ASSY - P

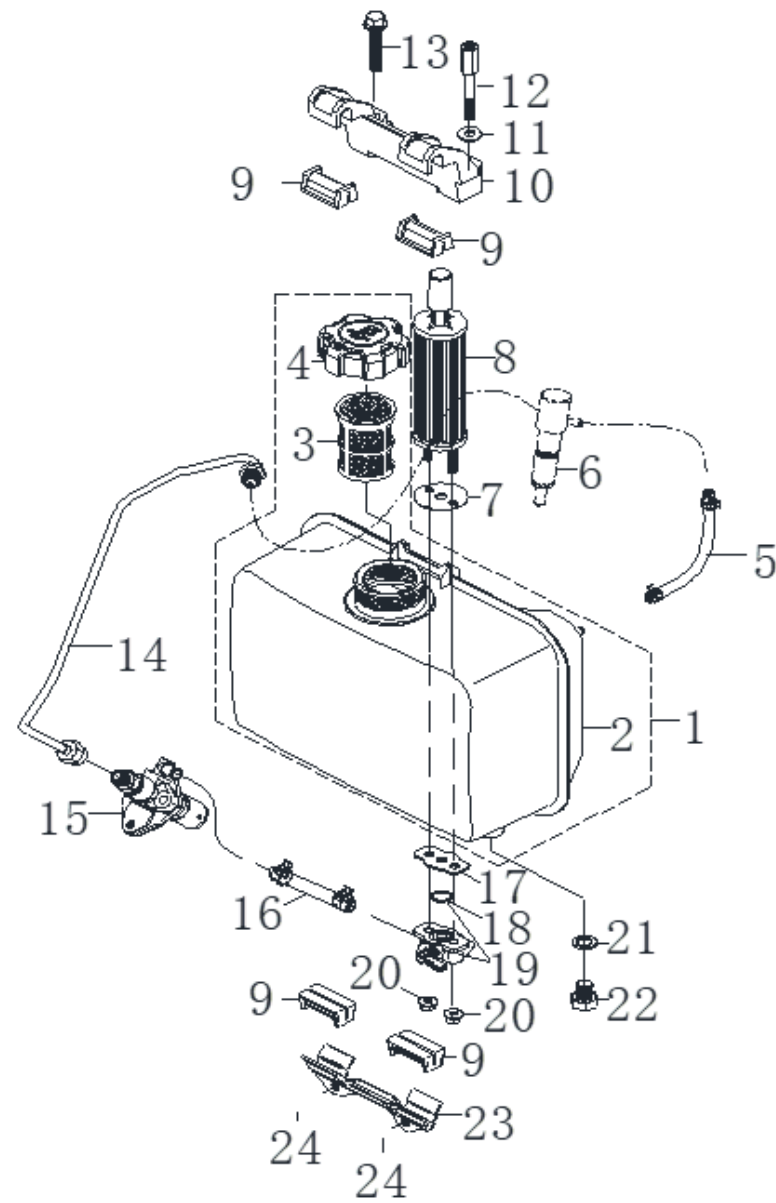

SL NO	PART NO	DESCRIPTION	SL NO	PART NO	DESCRIPTION
1	AM-178FSD-EP01	Fuel Tank Assy	17	AM-178FSD-EP17	Fuel tank switch gasket
2	AM-178FSD-EP02	Fuel Tank Assy	18	AM-178FSD-EP18	O-ring rubber seal
3	AM-178FSD-EP03	Oil filler screen combination	19	AM-178FSD-EP19	Fuel Tank Gock Assy
4	AM-178FSD-EP04	Fuel tank cap combination	20	AM-178FSD-EP20	Flange Bolt
5	AM-178FSD-EP05	fuel Return pipe assembly	21	AM-178FSD-EP21	Fuel Tank Plug Seat
6	AM-178FSD-EP06	NA	22	AM-178FSD-EP22	Bolt
7	AM-178FSD-EP07	Gasket	23	AM-178FSD-EP23	Lower Stay Assy
8	AM-178FSD-EP08	Fuel filter assembly	24	AM-178FSD-EP24	Flange Nut
9	AM-178FSD-EP09	Fuel Tank Damper			
10	AM-178FSD-EP10	Washer			
11	AM-178FSD-EP11	Upper Stay			
12	AM-178FSD-EP12	Upper Stay Bolt			
13	AM-178FSD-EP13	Bolt			
14	AM-178FSD-EP14	Fuel Injection Pipe Assy			
15	AM-178FSD-EP15	NA			
16	AM-178FSD-EP16	Oil Pipe			

# THROTTLE CONTROL ASSY - Q

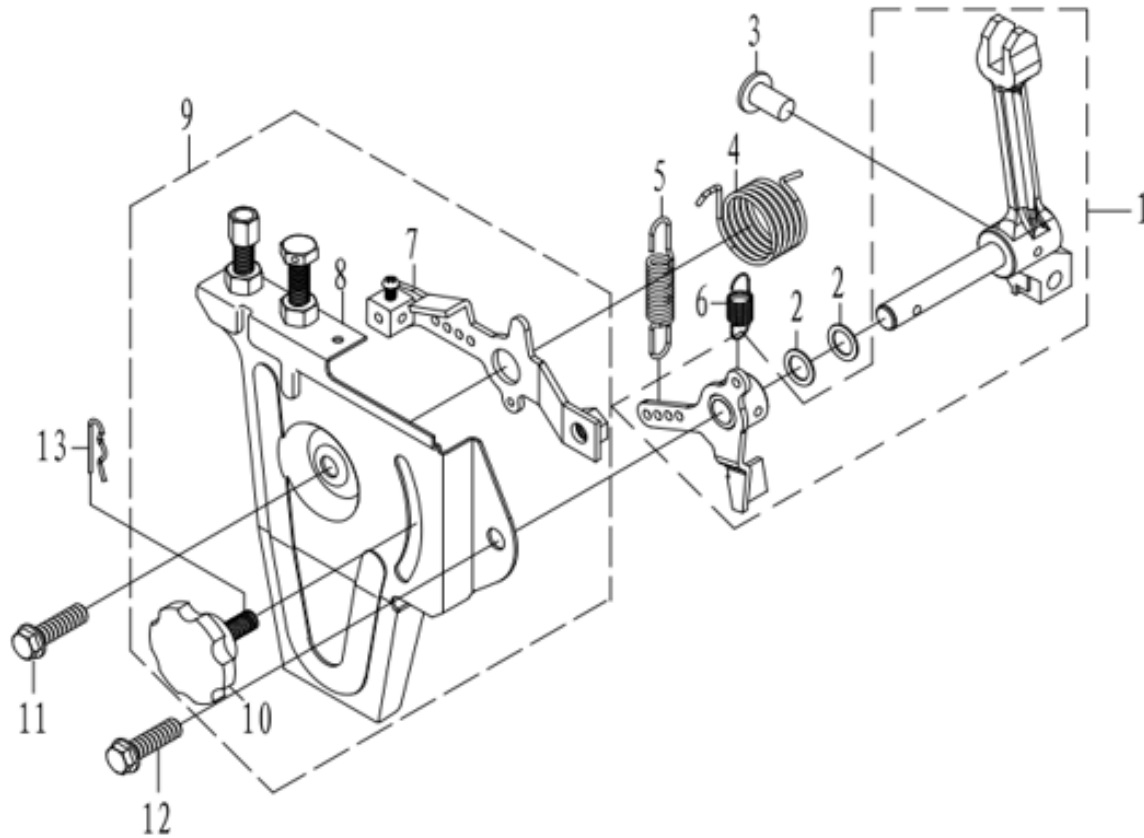

SL NO	PART NO	DESCRIPTION
1	AM-178FSD-EQ01	Lever Fork
2	AM-178FSD-EQ02	Fork shaft adjusting washer
3	AM-178FSD-EQ03	Speed cap
4	AM-178FSD-EQ04	Reset Spring
5	AM-178FSD-EQ05	Governor Spring
6	AM-178FSD-EQ06	Fine Tuning Spring
7	AM-178FSD-EQ07	Speed control arm
8	AM-178FSD-EQ08	Speed control panel
9	AM-178FSD-EQ09	Control Panel
10	AM-178FSD-EQ10	Control Panel
11	AM-178FSD-EQ11	Flange Bolt
12	AM-178FSD-EQ12	Flange Bolt
13	AM-178FSD-EQ13	Adjusting Rod Clip

## EXHAUST ASSY - R

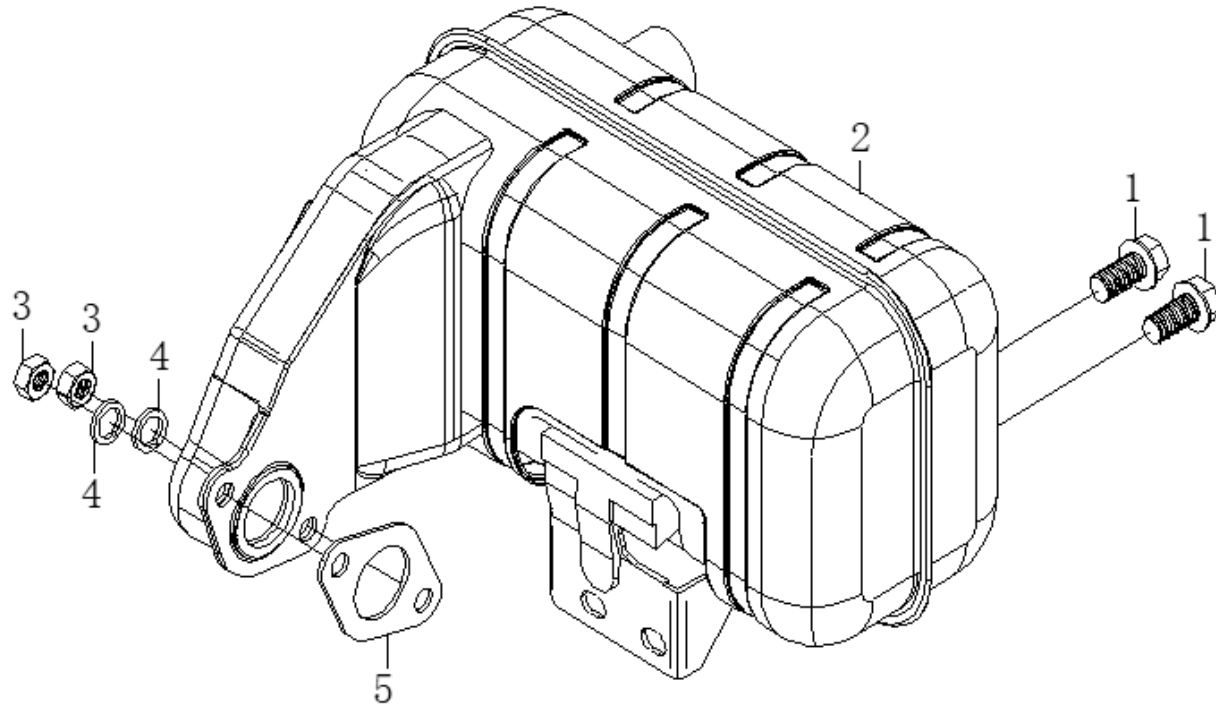

SL NO	PART NO	DESCRIPTION
1	AM-178FSD-ER01	Flange Bolt
2	AM-178FSD-ER02	Muffler Comp
3	AM-178FSD-ER03	Nut
4	AM-178FSD-ER04	Spring Washer
5	AM-178FSD-ER05	Muffler Gasket



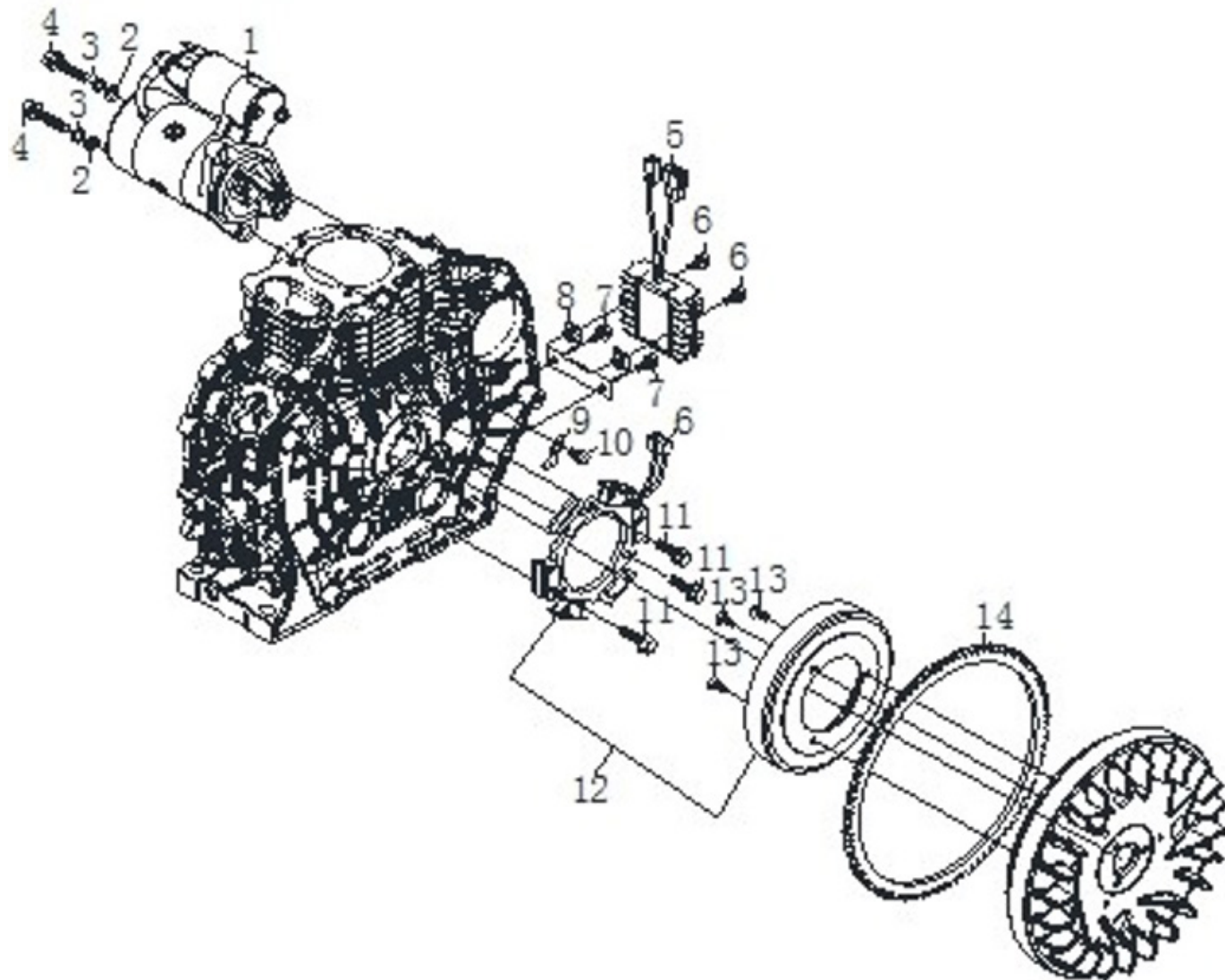

# FLYWHEEL AND GENERATOR ASSY - S



SL NO	PART NO	DESCRIPTION	SL NO	PART NO	DESCRIPTION
1	AM-178FSD-ES01	Starting Motor			
2	AM-178FSD-ES02	Flat Washer			
3	AM-178FSD-ES03	Spring Washer			
4	AM-178FSD-ES04	Bolt			
5	AM-178FSD-ES05	Regulator			
6	AM-178FSD-ES06	Bolt			
7	AM-178FSD-ES07	Bolt			
8	AM-178FSD-ES08	Regulator Support			
9	AM-178FSD-ES09	Wire Press Plate			
10	AM-178FSD-ES10	Bolt			
11	AM-178FSD-ES11	Bolt			
12	AM-178FSD-ES12	Flywheel Alternator			
13	AM-178FSD-ES13	Screw			
14	AM-178FSD-ES14	Flywheel Ring Gear			





# WARRANTY CARD

## CUSTOMER COPY

DATE _____	DATE OF DELIVERY _____	DEALERS OFFICIAL SEAL	DEALERS SIGN _____
PURCHASERS NAME & ADDRESS _____ _____	 CUSTOMER SIGN		
PRODUCT NAME	PRODUCT SERIAL NO.	INVOICE/DN NO.	
			





I/Will accept the terms and conditions of warranty as in the warranty card

## DEALERS COPY

DATE _____	DATE OF DELIVERY _____	DEALERS OFFICIAL SEAL	DEALERS SIGN _____
PURCHASERS NAME & ADDRESS _____ _____	 CUSTOMER SIGN		
PRODUCT NAME	PRODUCT SERIAL NO.	INVOICE/DN NO.	
			

I/Will accept the terms and conditions of warranty as in the warranty card

## COMPANY COPY

DATE _____	DATE OF DELIVERY _____	DEALERS OFFICIAL SEAL	DEALERS SIGN _____
PURCHASERS NAME & ADDRESS _____ _____	 CUSTOMER SIGN		
PRODUCT NAME	PRODUCT SERIAL NO.	INVOICE/DN NO.	
			

I/Will accept the terms and conditions of warranty as in the warranty card

1. LIMITED WARRANTY PERIOD : For a period of six months from the date of Sale / delivery of the product which ever is earlier. 2. LIMITED WARRANTY OBLIGATION : Replacement of defective part(s) by authorized dealer are free of charges. If found defective by reasons of defective material / poor workmanship, parts will be replaced and there will be no value re-imburement. 3. TERMS & CONDITIONS : a. Claims under warranty will be accepted on submission of Warranty Card duly filled and stamped by authorized dealer together with the original purchase document. : b. Shipping / transportation / Incidental charges incurred in replacing defective parts under warranty shall be borne by the purchaser

WARRANTY null & void if

- (i) Lack of maintenance, (ii) Incorrect use of the machine or tampering, (iii) Use of non-genuine spare parts, (iv) Usage of acids, solvents, or any flammable materials, (v) Non-usage of filter water / clear water / soft water & using water above 40°C temperature, (vi) While using the pressure washers to draw water which is contaminated with dust & solvents (eg. paint thinners, gasoline, oil, etc.), (vii) Repair done by unauthorized service people, (viii) Those parts subject to wear & tear due to normal operations and plastic parts, rubber items etc, (ix) Loose connections, faulty electrical fixtures & fluctuations in power supply.
- 4. Should any failure occur during or after the warranty period, customer does not have the right to interrupt payment / price discount.
- 5. Incidental or consequential damages like inconvenience commercial loss, loss of tie, mental agony etc.
- 6. Loss of any nature due to operation or non-operation is not covered under warranty.
- 7. All free service are at Dealer's service point only.
- 8. Warranty ceases if service is not done periodically.
- 9. The attached card should be completed and returned to Ratnagiri Impex Pvt. Ltd. for registration immediately after sale / delivery.
- 10. The warranty is void unless you register the warranty card with Ratnagiri Impex Pvt. Ltd.
- 11. The decision of Ratnagiri Impex Pvt. Ltd., in settling the warranty is final in all respects.
- 12. All disputes are subject to Bangalore Courts Jurisdiction

1. LIMITED WARRANTY PERIOD : For a period of six months from the date of Sale / delivery of the product which ever is earlier. 2. LIMITED WARRANTY OBLIGATION : Replacement of defective part(s) by authorized dealer are free of charges. If found defective by reasons of defective material / poor workmanship, parts will be replaced and there will be no value re-imburement. 3. TERMS & CONDITIONS : a. Claims under warranty will be accepted on submission of Warranty Card duly filled and stamped by authorized dealer together with the original purchase document. : b. Shipping / transportation / Incidental charges incurred in replacing defective parts under warranty shall be borne by the purchaser.

WARRANTY null & void if

- (i) Lack of maintenance, (ii) Incorrect use of the machine or tampering, (iii) Use of non-genuine spare parts, (iv) Usage of acids, solvents, or any flammable materials, (v) Non-usage of filter water / clear water / soft water & using water above 40°C temperature, (vi) While using the pressure washers to draw water which is contaminated with dust & solvents (eg. paint thinners, gasoline, oil, etc.), (vii) Repair done by unauthorized service people, (viii) Those parts subject to wear & tear due to normal operations and plastic parts, rubber items etc, (ix) Loose connections, faulty electrical fixtures & fluctuations in power supply.
- 4. Should any failure occur during or after the warranty period, customer does not have the right to interrupt payment / price discount.
- 5. Incidental or consequential damages like inconvenience commercial loss, loss of tie, mental agony etc.
- 6. Loss of any nature due to operation or non-operation is not covered under warranty.
- 7. All free service are at Dealer's service point only.
- 8. Warranty ceases if service is not done periodically.
- 9. The attached card should be completed and returned to Ratnagiri Impex Pvt. Ltd. for registration immediately after sale / delivery.
- 10. The warranty is void unless you register the warranty card with Ratnagiri Impex Pvt. Ltd.
- 11. The decision of Ratnagiri Impex Pvt. Ltd., in settling the warranty is final in all respects.
- 12. All disputes are subject to Bangalore Courts Jurisdiction

1. LIMITED WARRANTY PERIOD : For a period of six months from the date of Sale / delivery of the product which ever is earlier. 2. LIMITED WARRANTY OBLIGATION : Replacement of defective part(s) by authorized dealer are free of charges. If found defective by reasons of defective material / poor workmanship, parts will be replaced and there will be no value re-imburement. 3. TERMS & CONDITIONS : a. Claims under warranty will be accepted on submission of Warranty Card duly filled and stamped by authorized dealer together with the original purchase document. : b. Shipping / transportation / Incidental charges incurred in replacing defective parts under warranty shall be borne by the purchaser.

WARRANTY null & void if

- (i) Lack of maintenance, (ii) Incorrect use of the machine or tampering, (iii) Use of non-genuine spare parts, (iv) Usage of acids, solvents, or any flammable materials, (v) Non-usage of filter water / clear water / soft water & using water above 40°C temperature, (vi) While using the pressure washers to draw water which is contaminated with dust & solvents (eg. paint thinners, gasoline, oil, etc.), (vii) Repair done by unauthorized service people, (viii) Those parts subject to wear & tear due to normal operations and plastic parts, rubber items etc, (ix) Loose connections, faulty electrical fixtures & fluctuations in power supply.
- 4. Should any failure occur during or after the warranty period, customer does not have the right to interrupt payment / price discount.
- 5. Incidental or consequential damages like inconvenience commercial loss, loss of tie, mental agony etc.
- 6. Loss of any nature due to operation or non-operation is not covered under warranty.
- 7. All free service are at Dealer's service point only.
- 8. Warranty ceases if service is not done periodically.
- 9. The attached card should be completed and returned to Ratnagiri Impex Pvt. Ltd. for registration immediately after sale / delivery.
- 10. The warranty is void unless you register the warranty card with Ratnagiri Impex Pvt. Ltd.
- 11. The decision of Ratnagiri Impex Pvt. Ltd., in settling the warranty is final in all respects.
- 12. All disputes are subject to Bangalore Courts Jurisdiction



**FREE SERVICE COUPON (30DAYS/30HRS. WHICHEVER IS EARLIER)**

MODEL

SERIAL NUMBER

PDI DATE

SERVICE NO.

PURCHASE BILL NO.

DATE

DEALERS OFFICE SEAL

- 1. Check and test the fuel mixture
- 3. Check , clean and adjust the spark plug
- 5. Check and sparken the cutting tools
- 7. Start and check the noise, vibration, loosen etc..

OPERATIONS

- 2. check and clean the air filter
- 4. Check and adjust the carburetor tuning
- 6. Product familirisation on usage
- 8. Routine maintenance and shortage.

**FREE SERVICE COUPON (30DAYS/30HRS. WHICHEVER IS EARLIER)**

MODEL

SERIAL NUMBER

PDI DATE

SERVICE NO.

PURCHASE BILL NO.

DATE

DEALERS OFFICE SEAL

- 1. Check and test the fuel mixture
- 3. Check , clean and adjust the spark plug
- 5. Check and sparken the cutting tools
- 7. Start and check the noise, vibration, loosen etc..

OPERATIONS

- 2. check and clean the air filter
- 4. Check and adjust the carburetor tuning
- 6. Product familirisation on usage
- 8. Routine maintenance and shortage.

**FREE SERVICE COUPON (30DAYS/30HRS. WHICHEVER IS EARLIER)**

MODEL

SERIAL NUMBER

PDI DATE

SERVICE NO.

PURCHASE BILL NO.

DATE

DEALERS OFFICE SEAL

- 1. Check and test the fuel mixture
- 3. Check , clean and adjust the spark plug
- 5. Check and sparken the cutting tools
- 7. Start and check the noise, vibration, loosen etc..

OPERATIONS

- 2. check and clean the air filter
- 4. Check and adjust the carburetor tuning
- 6. Product familirisation on usage
- 8. Routine maintenance and shortage.

# DOS

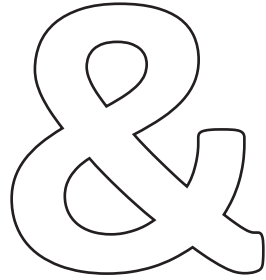

# DONT'S

1. Always read the instruction manual supplied along with the equipments and understand the correct installation and operating procedures before attempting to use the equipments.
2. It is important to use the personal protection equipments such as head helmet with visor, ear defenders, goggles, safety gloves, cut resistant shoes, trousers and jackets while operating potentially dangerous machines
3. Avoid untrained persons using the equipments. Children must not be allowed to handle these equipments
4. Always use genuine spares and accessories in repairs and usage to derive maximum life of the equipments.
5. Always keep the equipments in good working condition to minimize loss of output as well as to reduce the pollution and save the environment
6. Do not use the machine within range of persons unless they wear protective clothing
7. Do not operate the machine when fatigued or under the influence of alcohol or drugs
8. When the machine is running, please maintain a constant water supply. Without water circulation will damage the sealing rings of the machine.
9. For more query kindly contact for our Service Center/Dealer/ franchise

# Agrimate Army For Pest Control

ANY WHERE - ANY TIME - ANY CROP

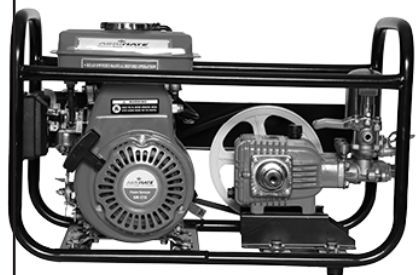
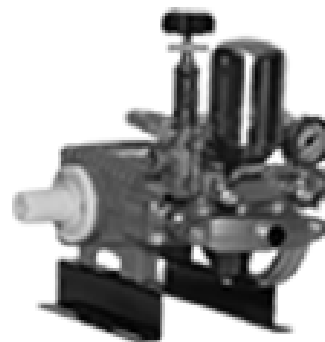

Marketed by:

**ratnagiri  
impex**

BRINGING YOU THE FUTURE... NOW

**RATNAGIRI IMPEX PVT., LTD.,**

Annapurna House, #1 / 1G, 7th Cross, New  
Guddadahalli

Mysore Road, Bangalore - 560 026

Missed Call : 7393 938 938

Email: [ask@agrimart.in](mailto:ask@agrimart.in)