

# INTERCULTIVATOR / POWER WEEDER

## AM-186FD ENGINE DIAGRAM



# ENGINE DIAGRAM & PART LIST OF AM-186FD

## CYLINDER HEAD ASSY - A

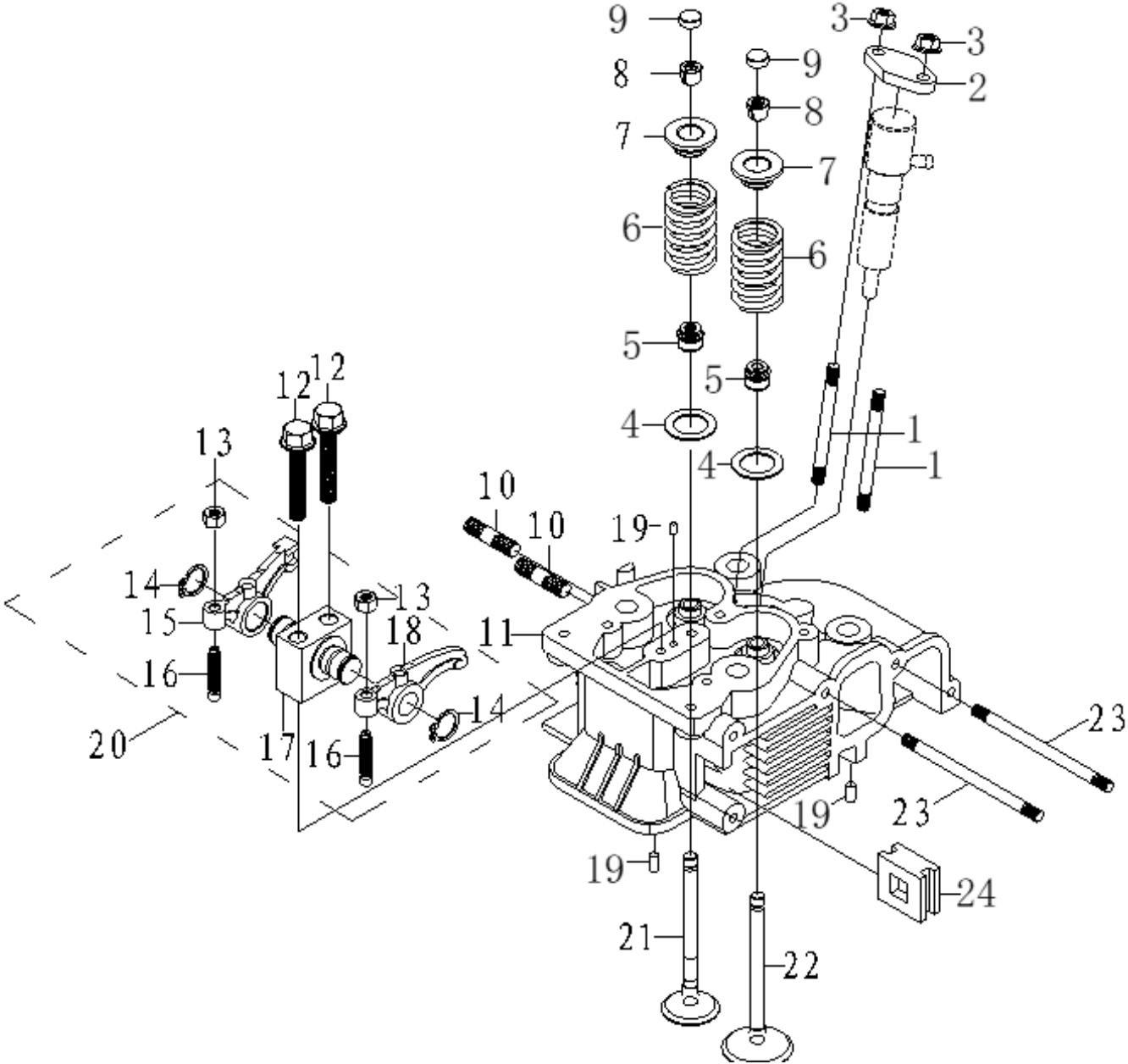

# ENGINE DIAGRAM & PART LIST OF AM-186FD

SL NO	PART NO	DESCRIPTION	SL NO	PART NO	DESCRIPTION
1	AM-186FD-A01	Bolt Stud	17	AM-186FD-A17	Rock Arm Seat
2	AM-186FD-A02	Fuel Injection Clamp	18	AM-186FD-A18	Valve Rock Arm Inlet
3	AM-186FD-A03	Flange Nut	19	AM-186FD-A19	Lock Pin
4	AM-186FD-A04	Valve Spring Washer	20	AM-186FD-A20	Rock Arm Assy
5	AM-186FD-A05	Valve Seal	21	AM-186FD-A21	Valve Exhaust Side
6	AM-186FD-A06	Spring Valve	22	AM-186FD-A22	Valve Inlet Side
7	AM-186FD-A07	Valve Spring Seat Assy	23	AM-186FD-A23	Bolt Stud
8	AM-186FD-A08	Cotter	23.1	AM-186FD-A23.1	Bolt Stud
9	AM-186FD-A09	Valve Adjusting Plate	24	AM-186FD-A24	Block, Cylinder Head.
10	AM-186FD-A10	Bolt Stud,			
11	AM-186FD-A11	Cylinder Head Assy			
12	AM-186FD-A12	Flange Bolt			
13	AM-186FD-13	Lock Nut			
14	AM-186FD-B14	Clip Piston Pin			
15	AM-186FD-B15	Valve Rock Arm Exhaust			
16	AM-186FD-B16	Valve Screw			

# ENGINE DIAGRAM & PART LIST OF AM-186FD

## CRANK CASE ASSY - B

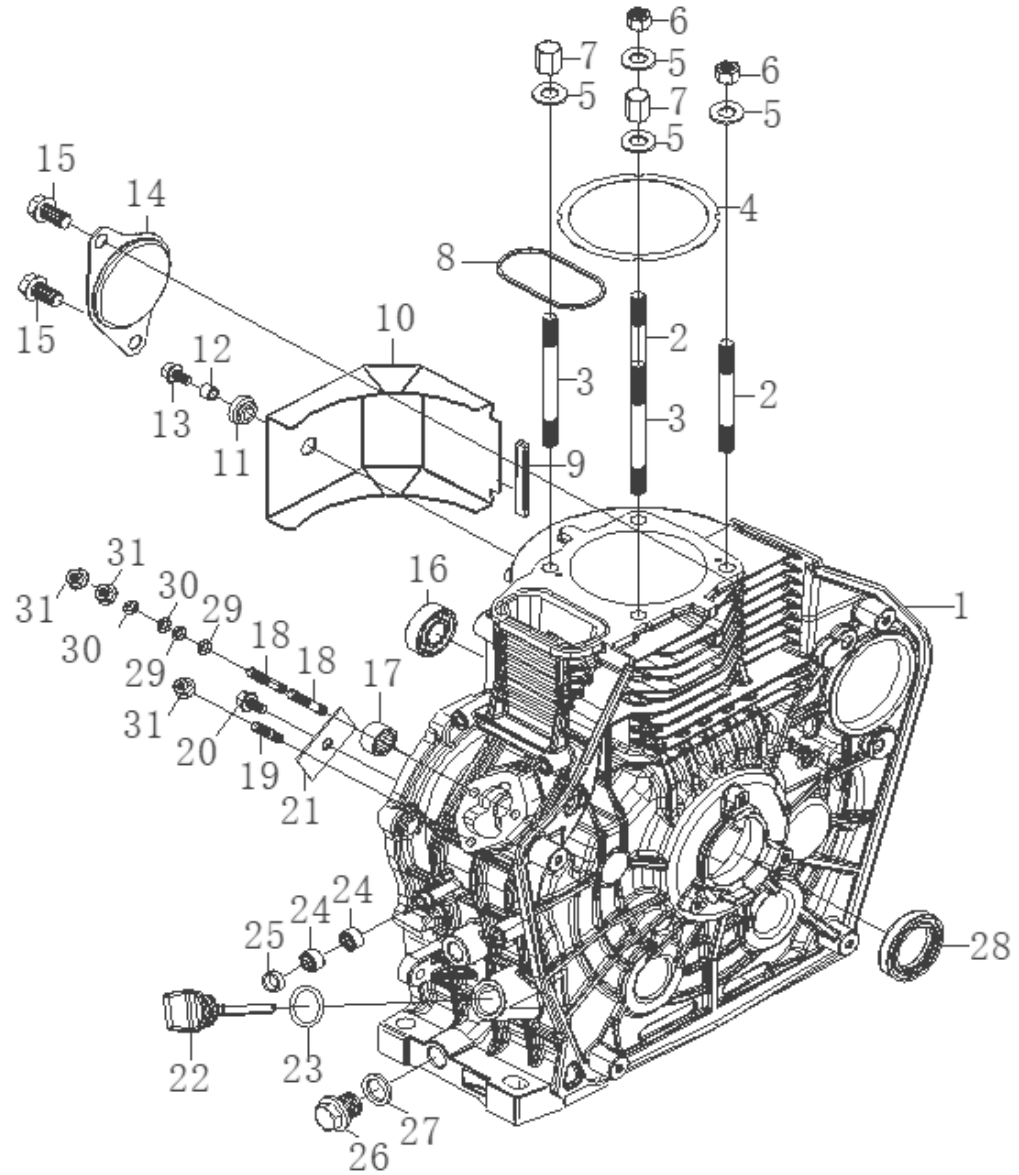

# ENGINE DIAGRAM & PART LIST OF AM-186FD

SL NO	PART NO	DESCRIPTION	SL NO	PART NO	DESCRIPTION
1	AM-186FD-B01	Crankcase	17	AM-186FD-B17	Needle Bearing
2	AM-186FD-B02	Cylinder Head Stud	18	AM-186FD-B18	Bolt Stud
3	AM-186FD-B03	Cylinder Head Stud	19	AM-186FD-B19	Bolt Stud
4	AM-186FD-B04	Cylinder Head gasket, Copper	20	AM-186FD-B20	Bolt
5	AM-186FD-B05	Washer	21	AM-186FD-B21	Retainer
6	AM-186FD-B06	Nut,Cylinder Head	22	AM-186FD-B22	Oil Dipstick
7	AM-186FD-B07	Nut,Cylinder Head Thick	23	AM-186FD-B23	O-Ring
8	AM-186FD-B08	Rectangle Seal Ring	24	AM-186FD-B24	Needle Bearing
9	AM-186FD-B09	Cooling Guide Plate gasket, Plastic	25	AM-186FD-B25	Oil Seal
10	AM-186FD-B10	Wind Guide Plate	26	AM-186FD-B26	Drain Plug
11	AM-186FD-B11	Vibration Isolator,Cooling Guide Plate	27	AM-186FD-B27	Oil Plug Seal
12	AM-186FD-B12	Lining	28	AM-186FD-B28	Oil Seal
13	AM-186FD-B13	Flange Bolt	29	AM-186FD-B29	Washer
14	AM-186FD-B14	Starter Mounting Cover	30	AM-186FD-B30	Spring Washer
15	AM-186FD-B15	Flange Bolt	31	AM-186FD-B31	Flange Nut
16	AM-186FD-B16	Ball Bearing			

# ENGINE DIAGRAM & PART LIST OF AM-186FD

## CRANK CASE COVER ASSY - C

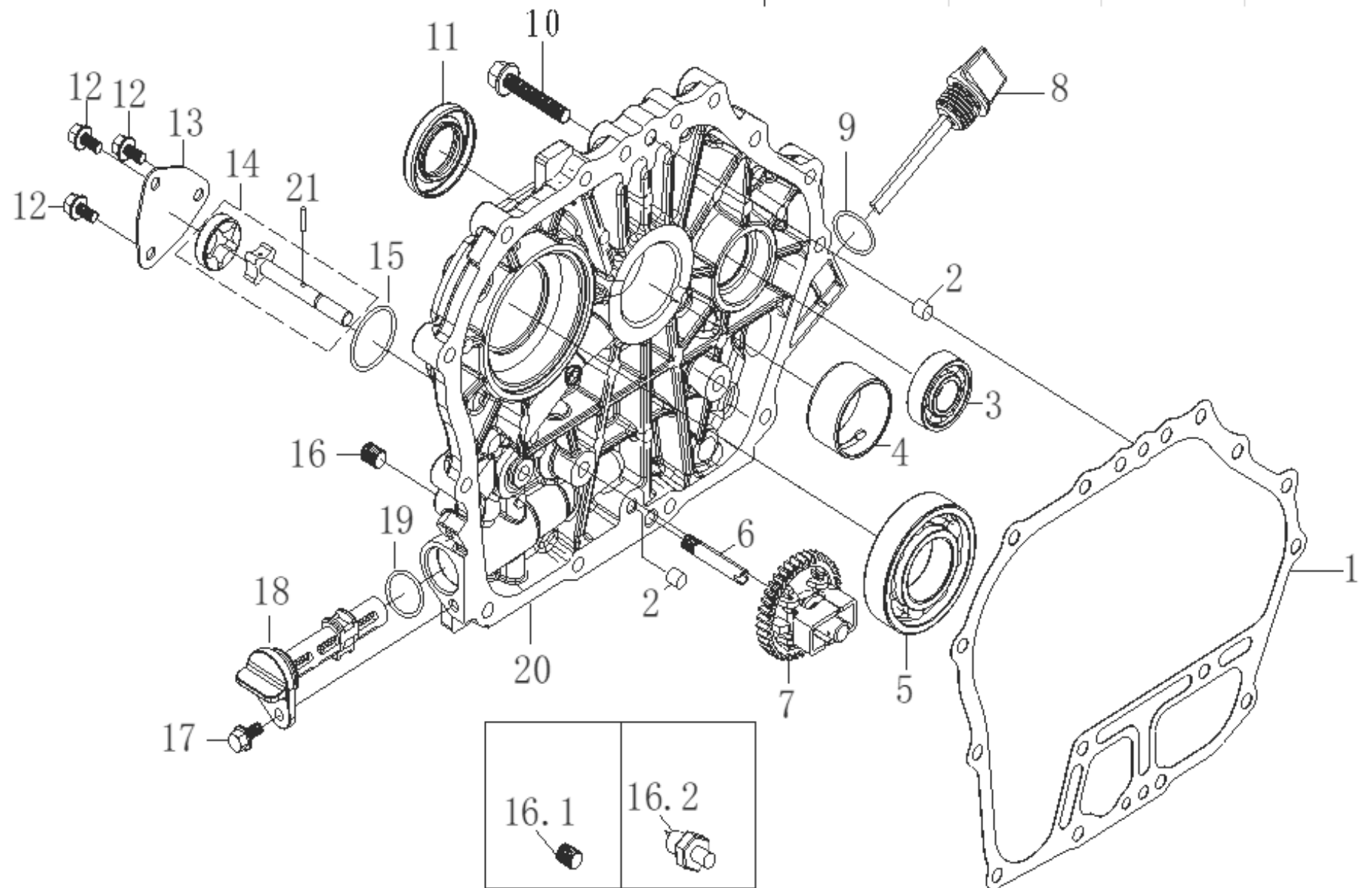

# ENGINE DIAGRAM & PART LIST OF AM-186FD

SL NO	PART NO	DESCRIPTION	SL NO	PART NO	DESCRIPTION
1	AM-186FD-C01	Gasket Crankcase Cover	16.2	AM-186FD-C16.2	Oil Pressure Sensor
2	AM-186FD-C02	Pin	17	AM-186FD-C17	Flange Bolt
3	AM-186FD-C03	Bearing	18	AM-186FD-C18	Engine Oil Filter Element
4	AM-186FD-C04	Crankshaft Bushing	19	AM-186FD-C19	Seal Ring
5	AM-186FD-C05	Ball Bearing	20	AM-186FD-C20	Cover, Crakcase
6	AM-186FD-C06	Oil Duct	21	AM-186FD-C21	Pin
7	AM-186FD-C07	Governor Gear Comp			
8	AM-186FD-C08	Oil Dipstick			
9	AM-186FD-C09	O-Ring			
10	AM-186FD-C10	Flange Bolt			
11	AM-186FD-C11	Oil Seal			
12	AM-186FD-C12	Flange Bolt			
13	AM-186FD-C13	Oil Pump Cover			
14	AM-186FD-C14	Oil Pump Assy			
15	AM-186FD-C15	Sealing Ring			
16.1	AM-186FD-C16	Block Bolt			

# CRANK FLY WHEEL ASSY- D

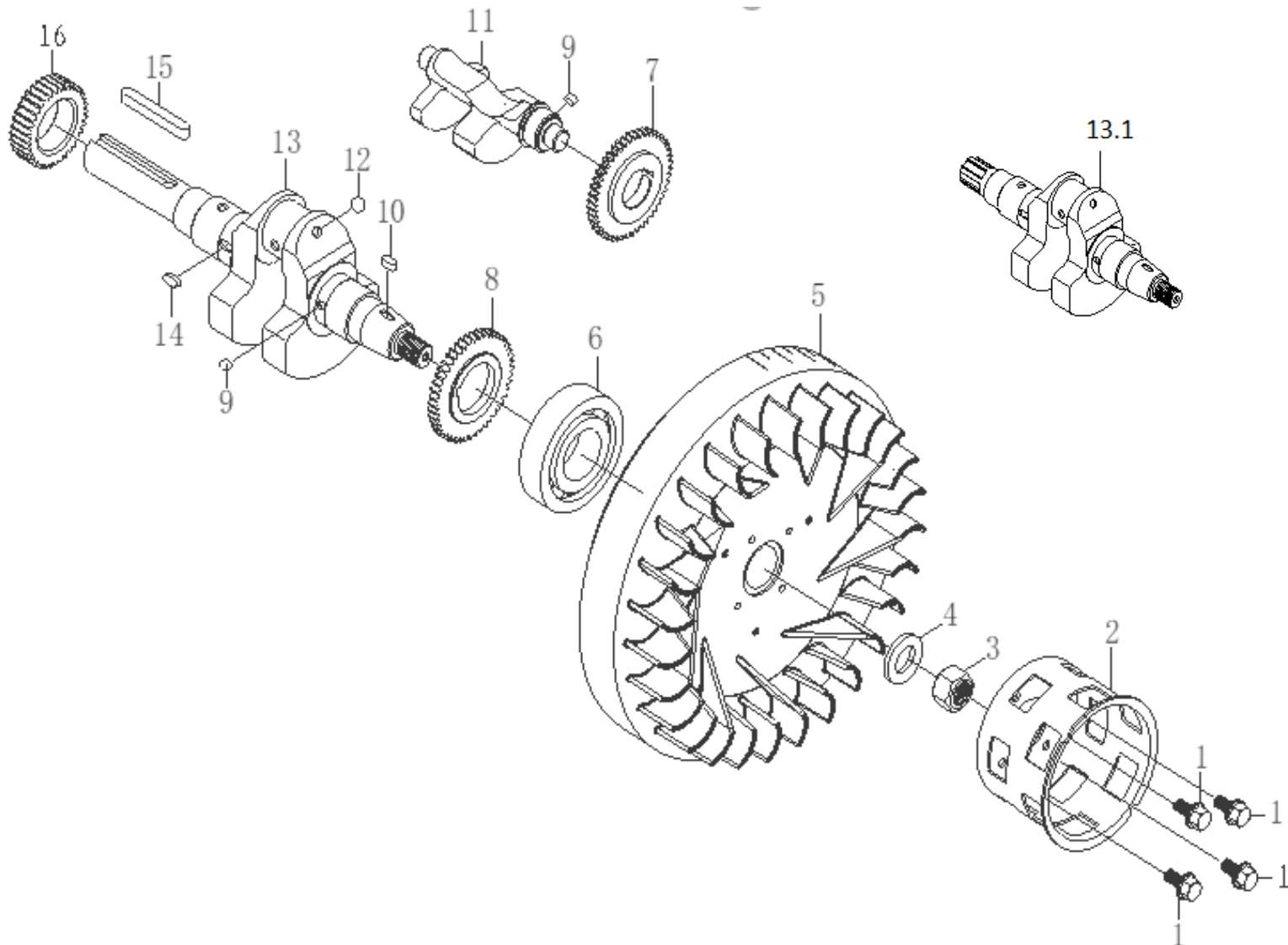

# ENGINE DIAGRAM & PART LIST OF AM-186FD

SL NO	PART NO	DESCRIPTION	SL NO	PART NO	DESCRIPTION
1	AM-186FD-D01	Flange Bolt	16	AM-186FD-D16	Crankshaft Timing Gear
2	AM-186FD-D02	Starter Pulley			
3	AM-186FD-D03	Flange Nut			
4	AM-186FD-D04	Washer			
5	AM-186FD-D05	Fly Wheel			
6	AM-186FD-D06	Ball Bearing			
7	AM-186FD-D07	Timing Gear Of Balance Shaft			
8	AM-186FD-D08	Drive Gear Of Balance Shsft			
9	AM-186FD-D09	Key			
10	AM-186FD-D10	Key			
11	AM-186FD-D11	Balancer Shaft			
12	AM-186FD-D12	Steel Ball			
13	AM-186FDB-D13	Crank Shaft Assy			
13.1	AM-186FD-D13.1	Crank Shaft Assy			
14	AM-186FD-D14	Key			
15	AM-186FD-D15	Key			

# ENGINE DIAGRAM & PART LIST OF AM-186FD

## PISTON CONNECTING - ROD ASSY - E

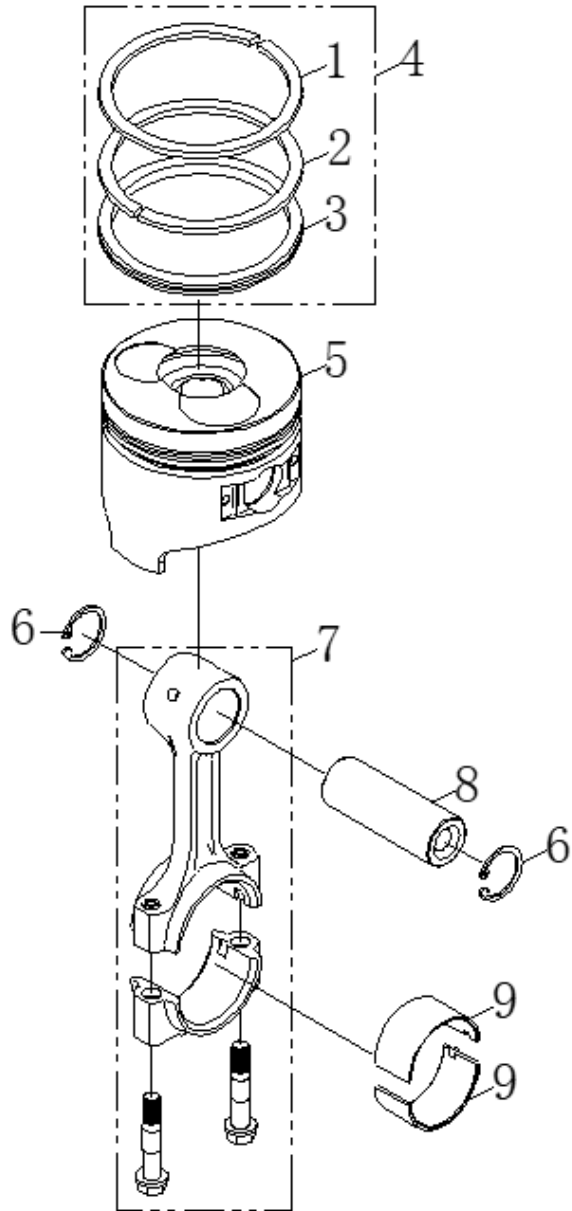

SL NO	PART NO	DESCRIPTION
1	AM-186FD-E01	NA
2	AM-186FD-E02	NA
3	AM-186FD-E03	NA
4	AM-186FD-E04	Piston Ring Assy
5	AM-186FD-E05	Piston
6	AM-186FD-E06	Clip Piston Pin
7	AM-186FD-E07	Connecting Rod Assy
8	AM-186FD-E08	Pin Piston
9	AM-186FD-E09	Bushing, Connect Rod

# ENGINE DIAGRAM & PART LIST OF AM-186FD

## CAMSHAFT ASSY - F

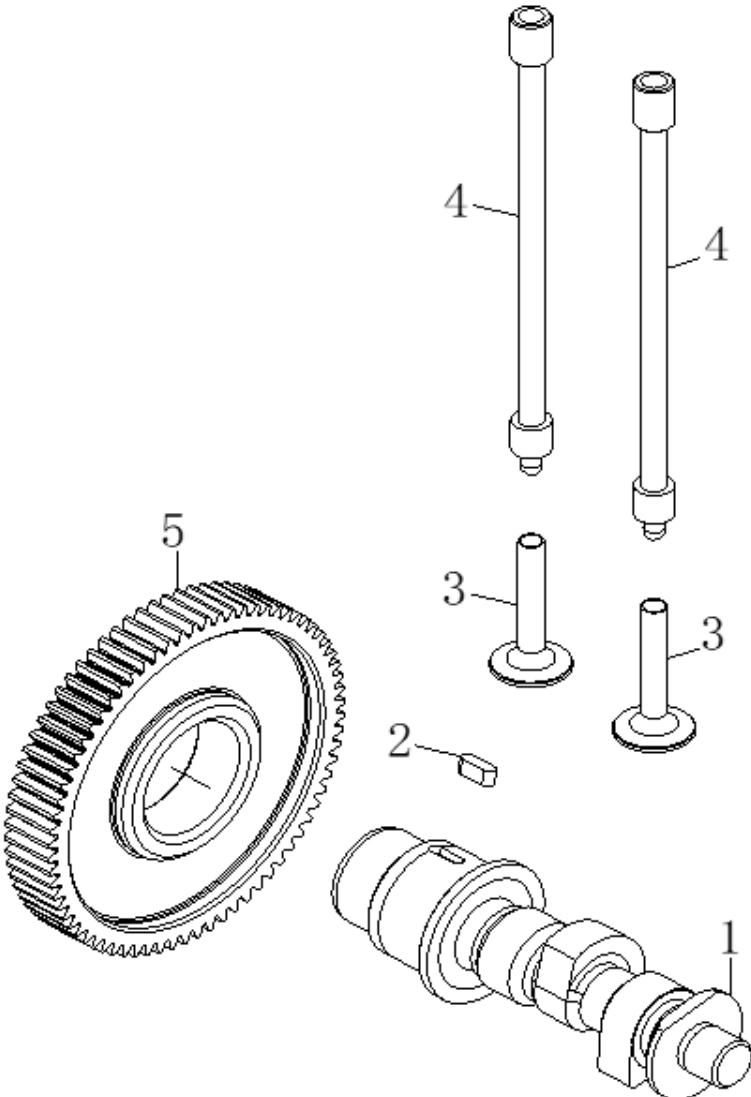

SL NO	PART NO	DESCRIPTION
1	AM-186FD-F01	Camshaft
2	AM-186FD-F02	Flat Key
3	AM-186FD-F03	Valve Tappet
4	AM-186FD-F04	Push Rod
5	AM-186FD-F05	Camshaft Timing Gear

# ENGINE DIAGRAM & PART LIST OF AM-186FD

## SELF STARTER ASSY - G

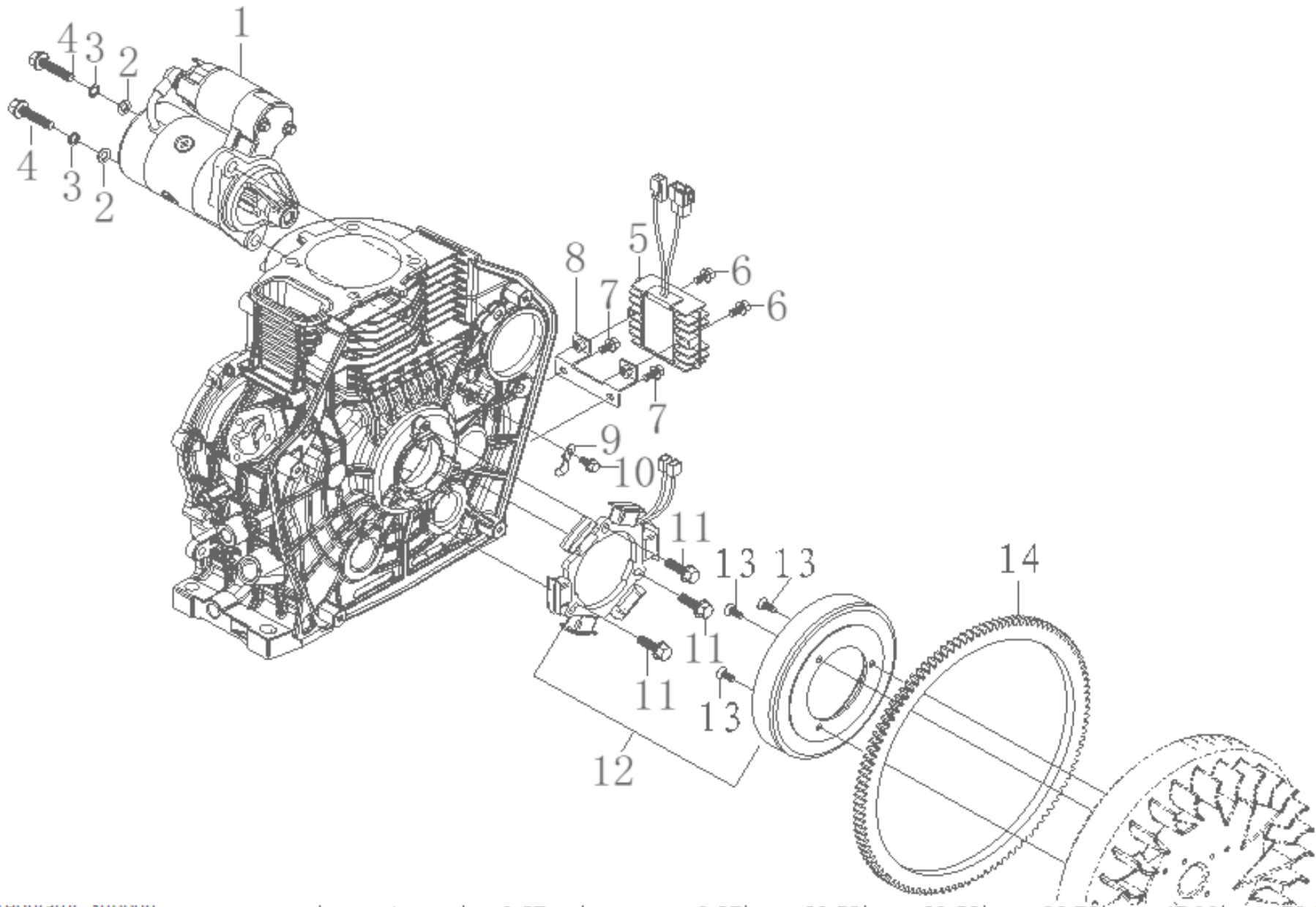

# ENGINE DIAGRAM & PART LIST OF AM-186FD

SL NO	PART NO	DESCRIPTION	SL NO	PART NO	DESCRIPTION
1	AM-186FD-G01	Starting Motor			
2	AM-186FD-G02	Spring Washer			
3	AM-186FD-G03	Flat Washer			
4	AM-186FD-G04	Bolt			
5	AM-186FD-G05	Regulator			
6	AM-186FD-G06	Bolt			
7	AM-186FD-G07	Bolt			
8	AM-186FD-G08	Regulator Support			
9	AM-186FD-G09	Wire Press Plate			
10	AM-186FD-G10	Bolt			
11	AM-186FD-G11	Bolt			
12	AM-186FD-G12	Flywheel Alternator			
13	AM-186FD-G13	Screw			
14	AM-186FD-G14	Ring Gear,Flywheel			

# ENGINE DIAGRAM & PART LIST OF AM-186FD

## STARTING COVER ASSY- H

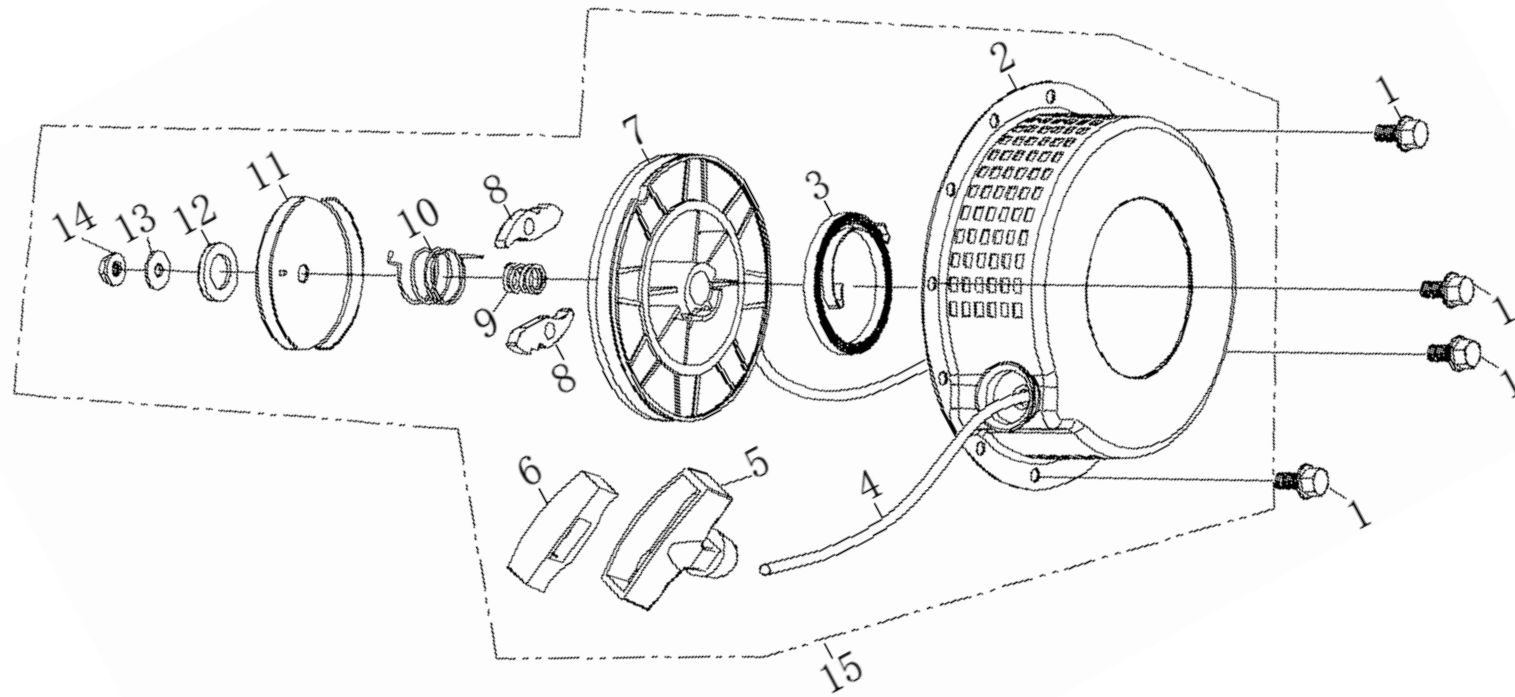

# ENGINE DIAGRAM & PART LIST OF AM-186FD

SL NO	PART NO	DESCRIPTION	SL NO	PART NO	DESCRIPTION
1	AM-186FD-H01	Flange Bolt			
2	AM-186FD-H02	Stater Cover Comp Recoil			
3	AM-186FD-H03	Spiral Spring			
4	AM-186FD-H04	Rope Recoil Starter			
5	AM-186FD-H05	Handle Starter			
6	AM-186FD-H06	Cover Handle Starter			
7	AM-186FD-H07	Starter Reel			
8	AM-186FD-H08	Patchet Starter			
9	AM-186FD-H09	Compress Spring			
10	AM-186FD-H10	Spring Return			
11	AM-186FD-H11	Spring Cover			
12	AM-186FD-H12	Rubber Washer			
13	AM-186FD-H13	Washer			
14	AM-186FD-H14	Nut			
15	AM-186FD-H15	Recoil Starter Assy			

# ENGINE DIAGRAM & PART LIST OF AM-186FD

## WIND SCOOPER -J

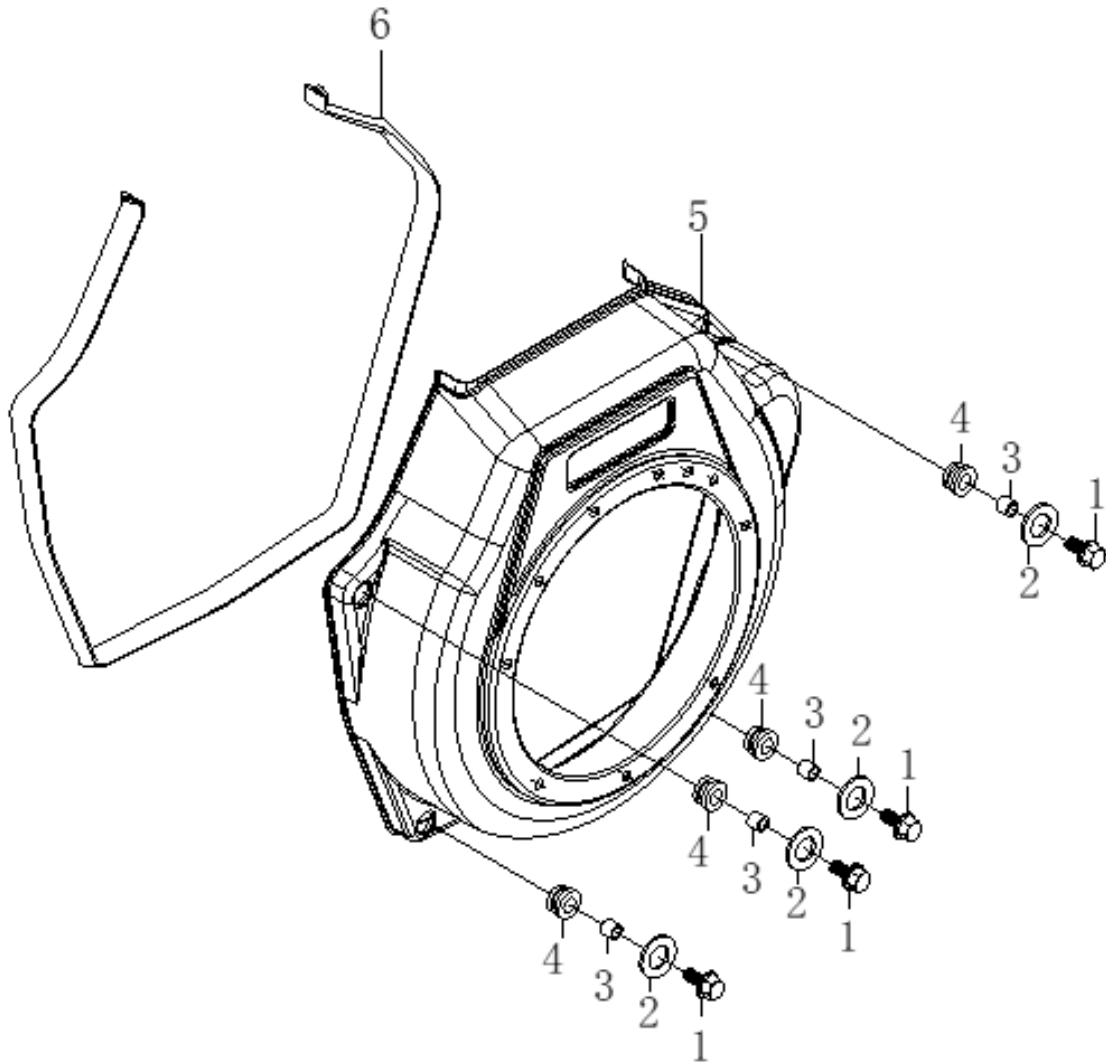

SL NO	PART NO	DESCRIPTION
1	AM-186FD-J01	Bolt
2	AM-186FD-J02	Washer
3	AM-186FD-J03	Collar
4	AM-186FD-J04	Shock Absorber
5	AM-186FD-J05	Wind Scooper Assy
6	AM-186FD-J06	Shock Absorber Seat

# AIR FILTER ASSY - K

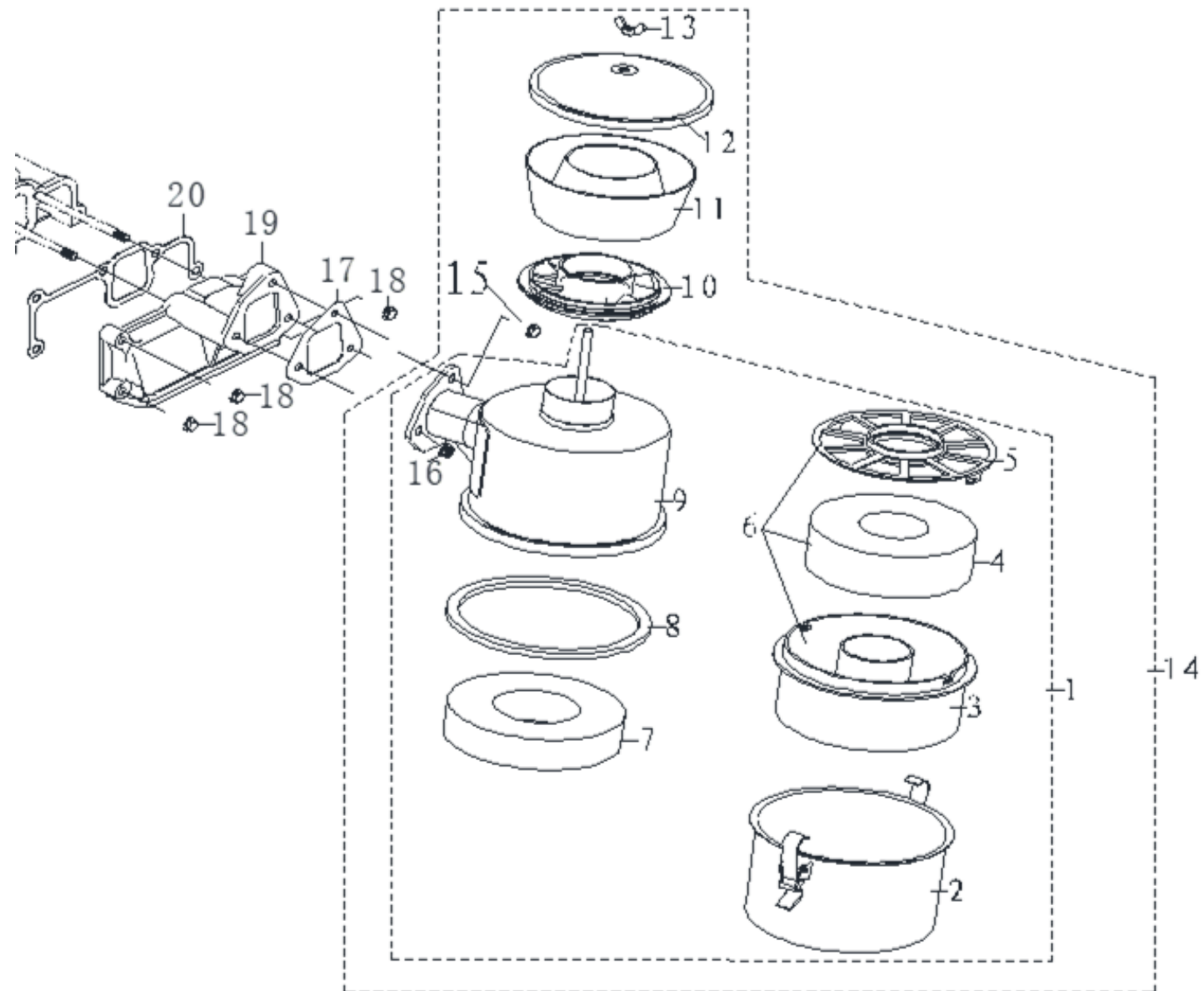

# ENGINE DIAGRAM & PART LIST OF AM-186FD

SL NO	PART NO	DESCRIPTION	SL NO	PART NO	DESCRIPTION
1	AM-186FD-K01	Cyclone Air Cleaner	17	AM-186FD-K17	Air Cleaner Gasket
2	AM-186FD-K02	Air Flter Sump	18	AM-186FD-K18	Flange Bolt
3	AM-186FD-K03	Filter Case	19	AM-186FD-K19	Intake Pipe
4	AM-186FD-K04	Steel Wire Filter	20	AM-186FD-K20	Intake Pipe Gasket
5	AM-186FD-K05	Filter Case,Cover			
6	AM-186FD-K06	Air filter foam filter element			
7	AM-186FD-K07	Foam Filter			
8	AM-186FD-K08	Filter box sealing ring			
9	AM-186FD-K09	Air filter cylinder assembly			
10	AM-186FD-K10	Air Filter Connecting Disc			
11	AM-186FD-K11	Air Cleaner Blade Base			
12	AM-186FD-K12	Air Cleaner Detached Body			
13	AM-186FD-K13	Wing nut square wing			
14	AM-186FD-K14	Air filter assembly			
15	AM-186FD-K15	Flange Bolt			
16	AM-186FD-K16	Flange Nut			

# ENGINE DIAGRAM & PART LIST OF AM-186FD

## FUEL PUMP ASSY- L

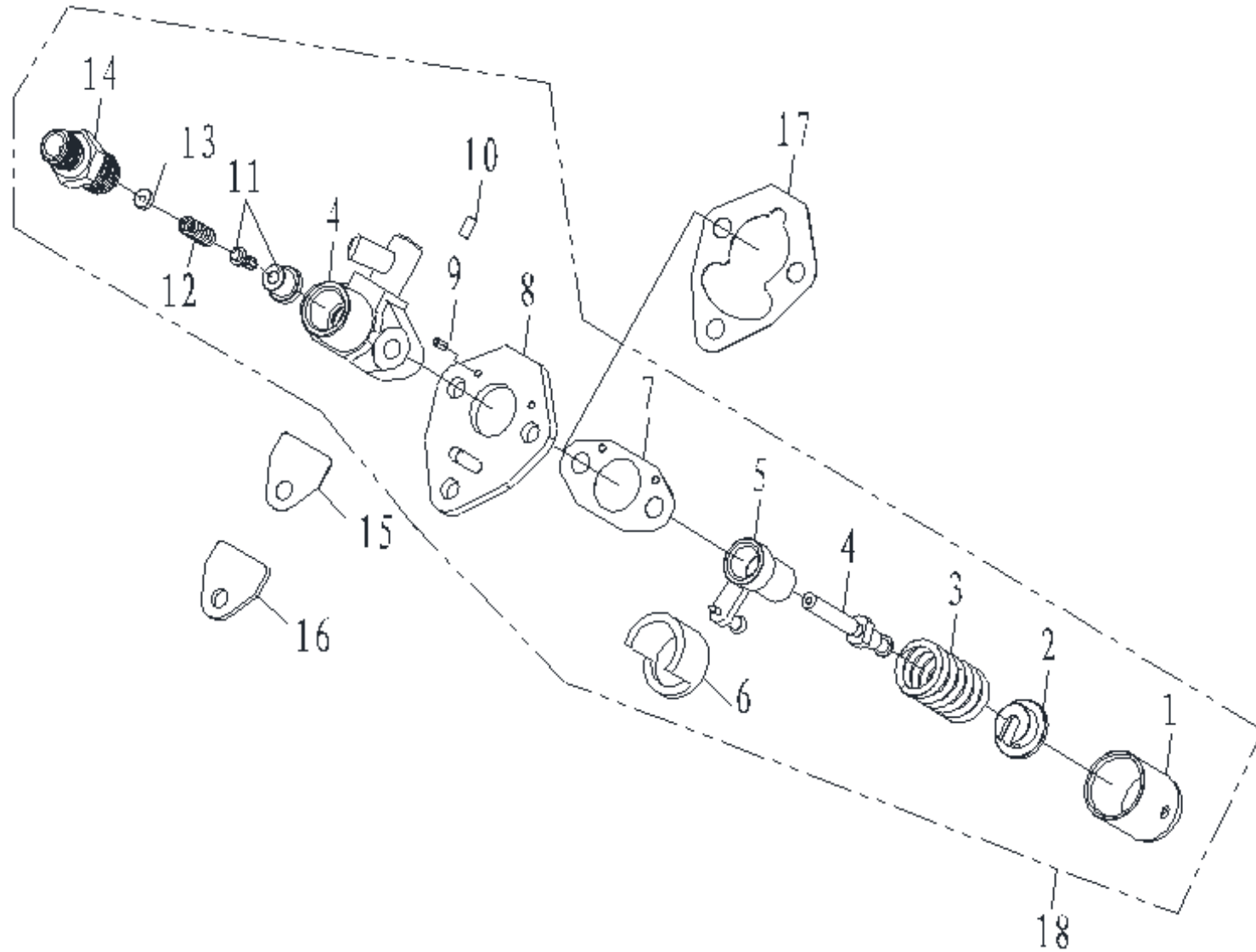

# ENGINE DIAGRAM & PART LIST OF AM-186FD

SL NO	PART NO	DESCRIPTION	SL NO	PART NO	DESCRIPTION
1	AM-186FD-L01	Tappet	17	AM-186FD-L17	Fuel Pump Gasket
2	AM-186FD-L02	Spring Holder	18	AM-186FD-L18	Fuel pump assy
3	AM-186FD-L03	Spring			
4	AM-186FD-L04	Plunger			
5	AM-186FD-L05	Fuel Limiting Sheath Weldment Assy			
6	AM-186FD-L06	Support			
7	AM-186FD-L07	Fuel Pump Gasket			
8	AM-186FD-L08	Washer			
9	AM-186FD-L09	Fip Connecting Plate			
10	AM-186FD-L10	Pin			
11	AM-186FD-L11	Oil outlet parts			
12	AM-186FD-L12	Fuel Delivery Valve Core			
13	AM-186FD-L13	Fuel Delivery Valve Seat			
14	AM-186FD-L14	Fuel Delhrery Valve forcing holder			
15	AM-186FD-L15	Fuel Delhrery Gasket			
16	AM-186FD-L16	Fuel Pump Cover			

# FUEL INJECTION ASSY-M

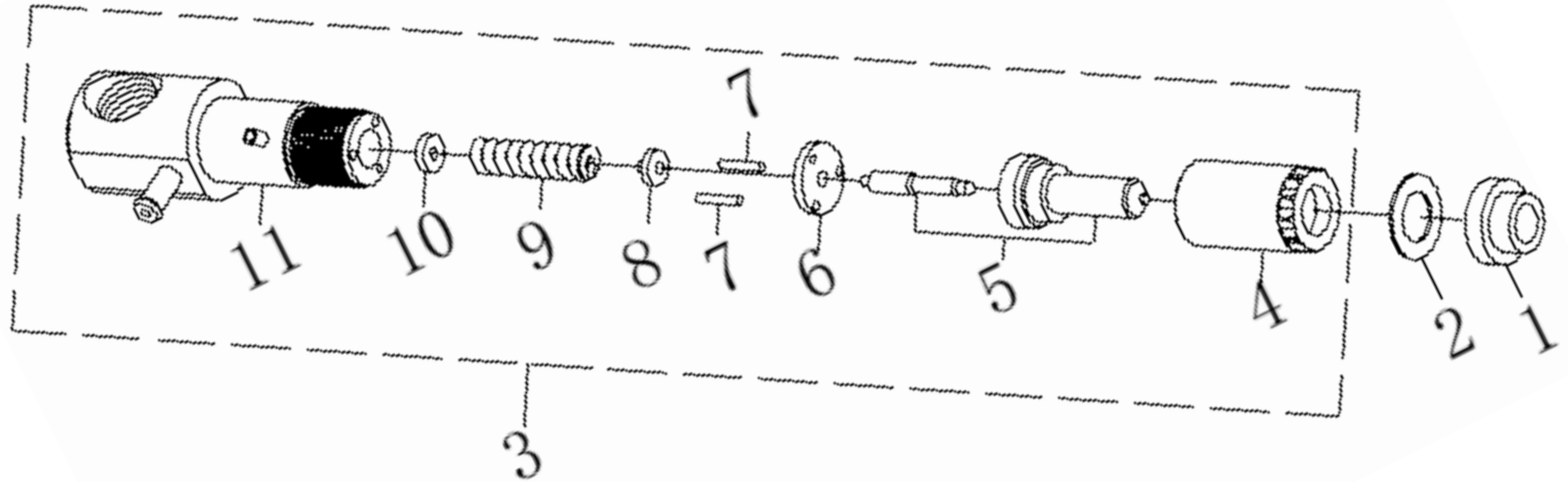





# ENGINE DIAGRAM & PART LIST OF AM-186FD

## FUEL OIL ASSY - P

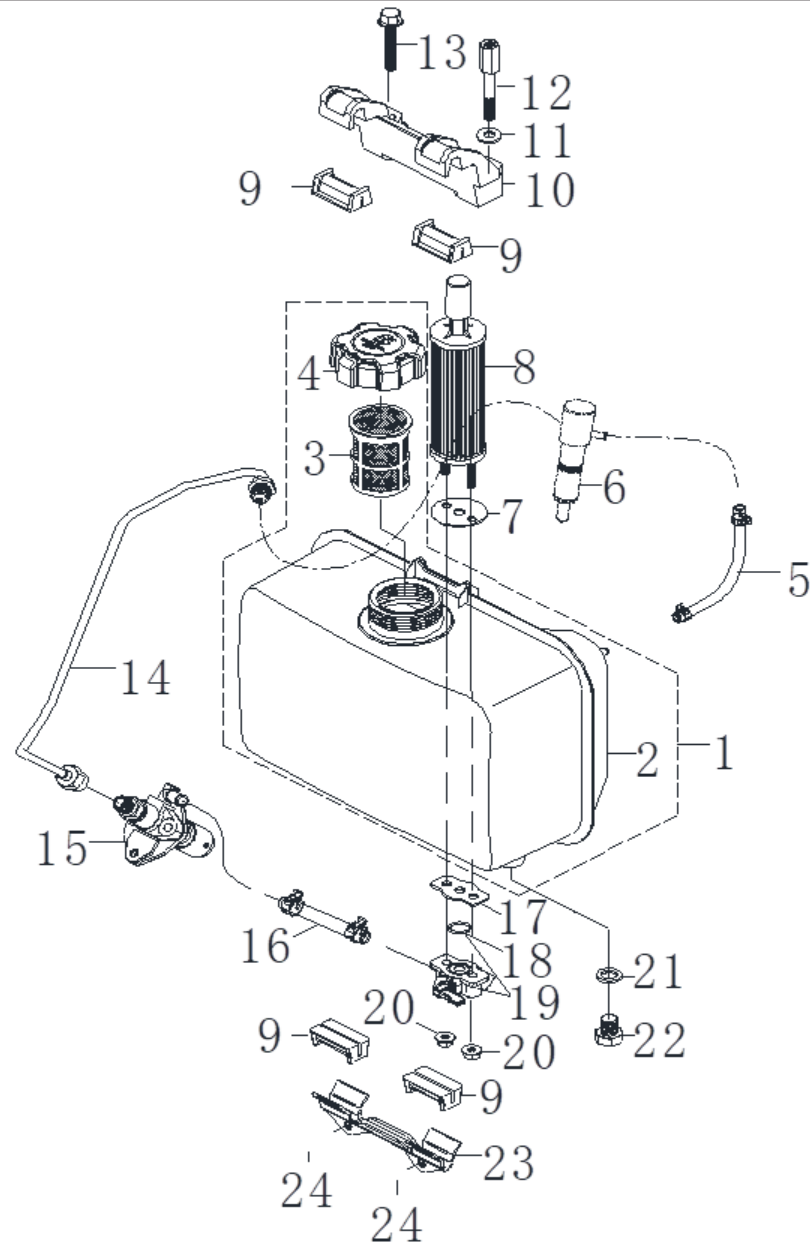

## ENGINE DIAGRAM & PART LIST OF AM-186FD

SL NO	PART NO	DESCRIPTION	SL NO	PART NO	DESCRIPTION
1	AM-186FD-P01	Fuel Tank Assy	17	AM-186FD-P17	Fuel tank switch gasket
2	AM-186FD-P02	Fuel Tank	18	AM-186FD-P18	O-shaped rubber sealing ring
3	AM-186FD-P03	Oil filler filter combination	19	AM-186FD-P19	Fuel Tank Gock Assy
4	AM-186FD-P04	Fuel tank cap combination	20	AM-186FD-P20	Flange Nut
5	AM-186FD-P05	Fuel return pipe assembly	21	AM-186FD-P21	Fuel Tank Plug Seat
6	AM-186FD-P06	Fuel Injector	22	AM-186FD-P22	Fule tank drain Plug
7	AM-186FD-P07	Gasket	23	AM-186FD-P23	Lower Stay Assy
8	AM-186FD-P08	Fuel filter assembly	24	AM-186FD-P24	Flange Bolt
9	AM-186FD-P09	Fuel Tank Damper	25	AM-186FD-P25	NA
10	AM-186FD-P10	Upper Stay	26	AM-186FD-P26	NA
11	AM-186FD-P11	Washer	27	AM-186FD-P27	NA
12	AM-186FD-P12	Upper Stay Bolt	28	AM-186FD-P28	NA
13	AM-186FD-P13	Bolt			
14	AM-186FD-P14	Fuel Injection Pipe			
15	AM-186FD-P15	Fuel Injection Pipe Assy			
16	AM-186FD-P16	Oil Pipe			

# ENGINE DIAGRAM & PART LIST OF AM-186FD

## THROTTLE CONTROL ASSY - Q

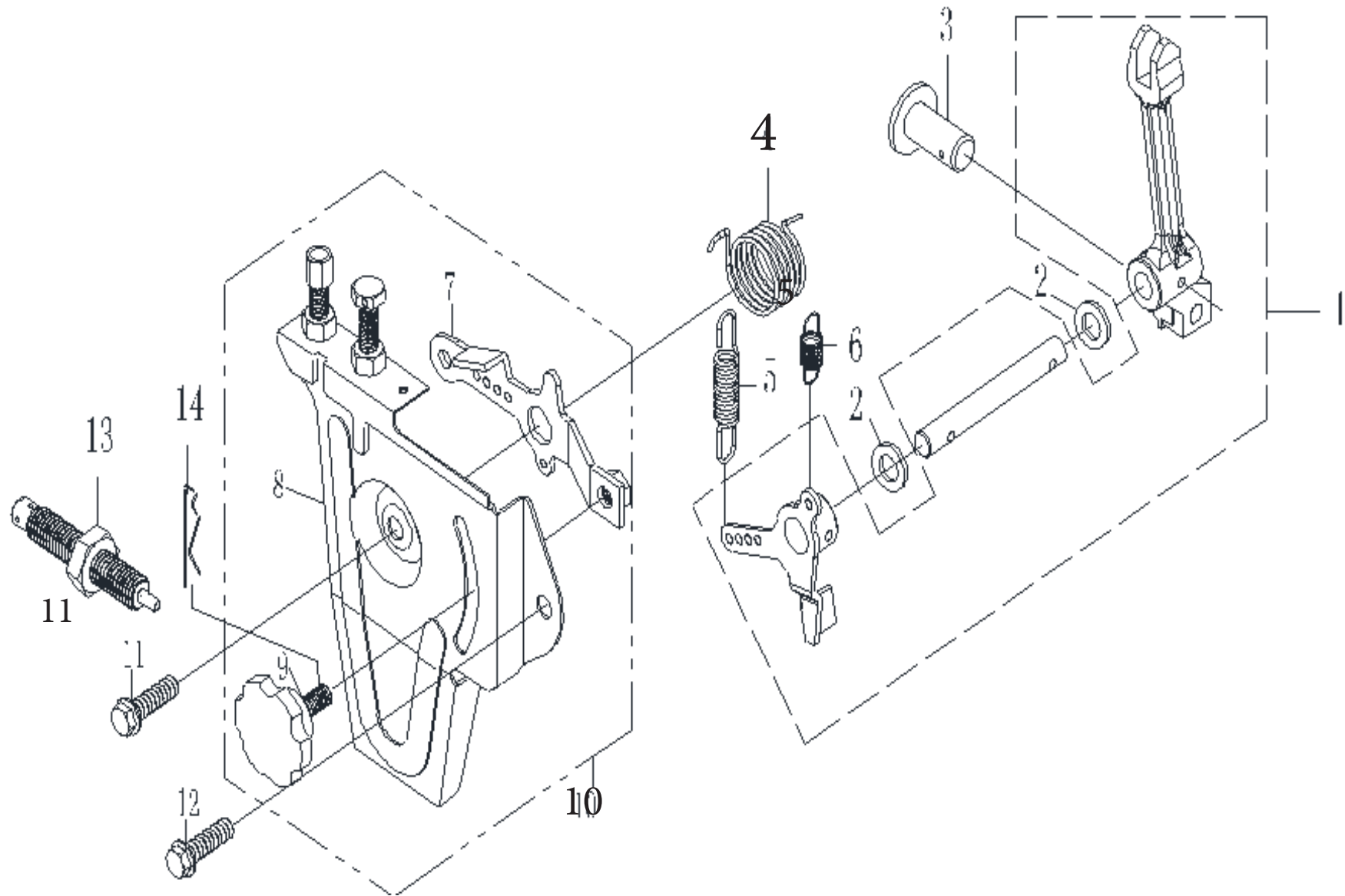

# THROTTLE CONTROL ASSY - Q

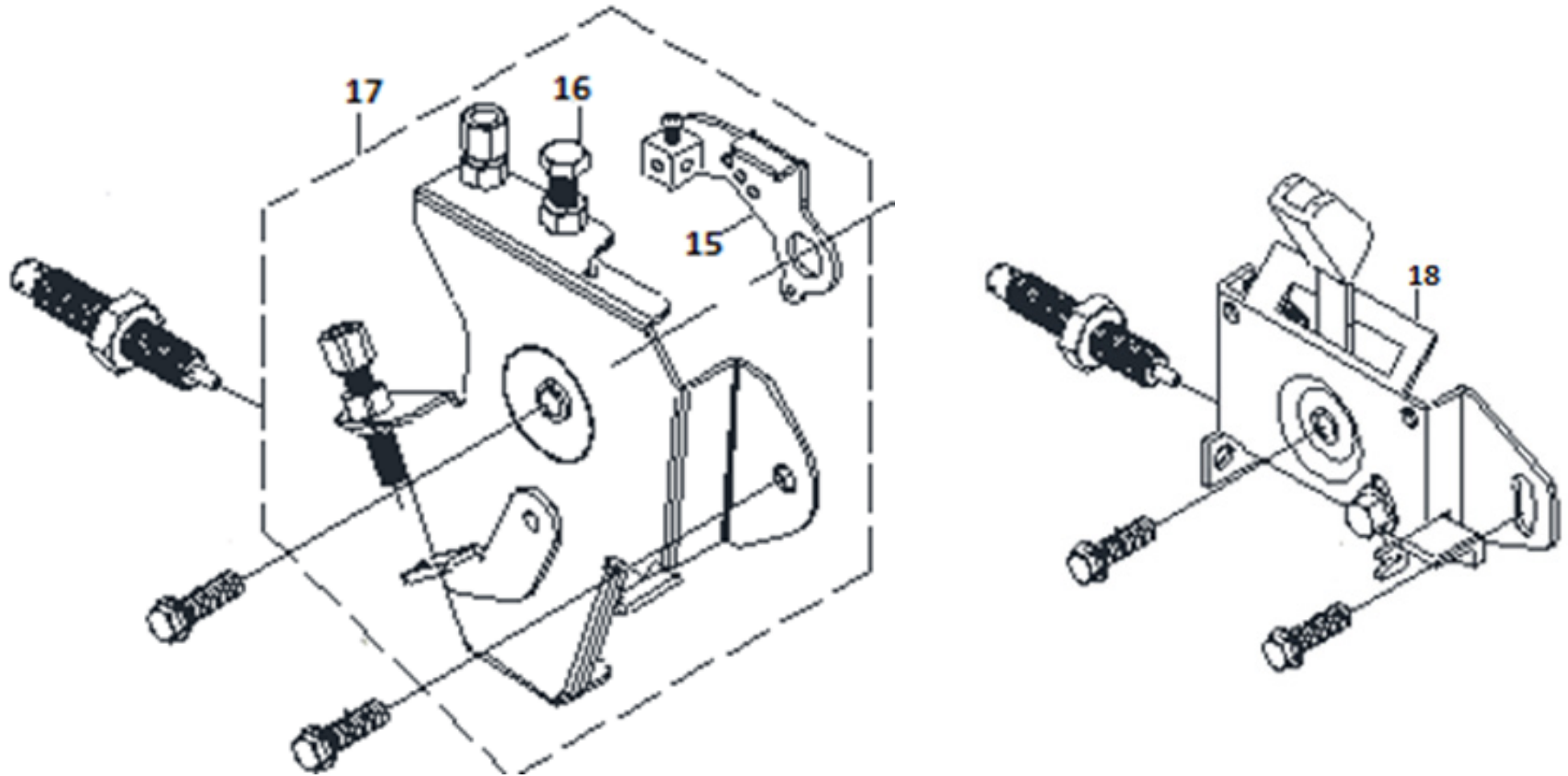

# ENGINE DIAGRAM & PART LIST OF AM-186FD

SL NO	PART NO	DESCRIPTION	SL NO	PART NO	DESCRIPTION
1	AM-186FD-Q01	Lever Fork	17	AM-186FD-Q17	control panel
2	AM-186FD-Q02	Adjusting Washer	18	AM-186FD-Q18	Control Panel
3	AM-186FD-Q03	Speed control cap			
4	AM-186FD-Q04	Reset Spring			
5	AM-186FD-Q05	Governor Spring			
6	AM-186FD-Q06	Fine Tuning Spring			
7	AM-186FD-Q07	Speed control arm			
8	AM-186FD-Q08	Speed control panel			
9	AM-186FD-Q09	Control Panel			
10	AM-186FD-Q10	Control Panel Assy			
11	AM-186FD-Q11	Flange Bolt			
12	AM-186FD-Q12	Flange Bolt			
13	AM-186FD-Q13	Control Lever Assy			
14	AM-186FD-Q14	Adjusting Rod Clip			
15	AM-186FD-Q15	speed control arm			
16	AM-186FD-Q16	Speed control Panel			



# ENGINE DIAGRAM & PART LIST OF AM-186FD

## SLPIT CRANK CASE - S

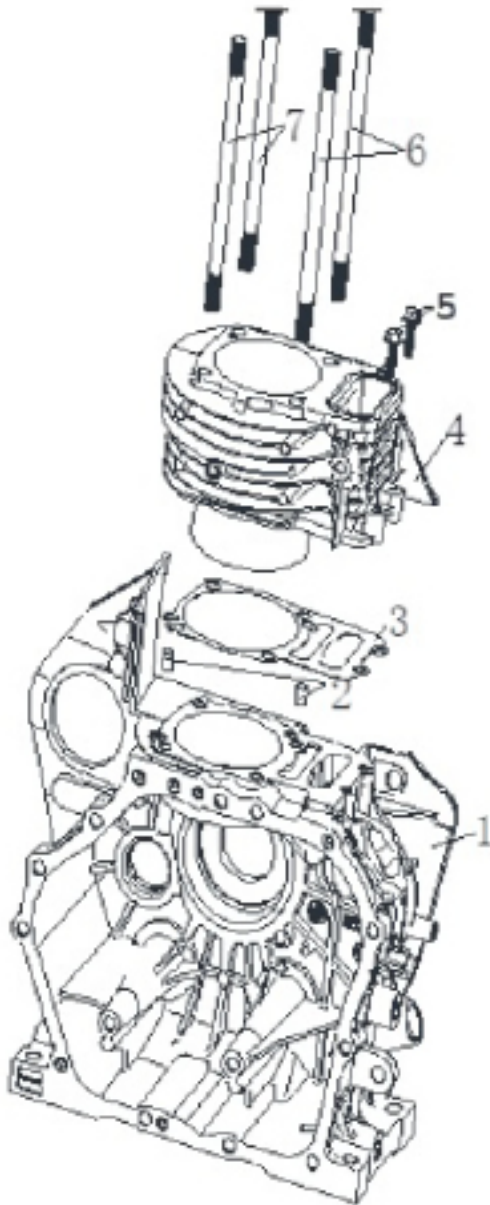

SL NO	PART NO	DESCRIPTION
1	AM-186FD-S01	Crankcase Electric Start_Split Type
2	AM-186FD-S02	Cylindrical pin
3	AM-186FD-S03	Cylinder block gasket
4	AM-186FD-S04	Cylinder block
5	AM-186FD-S05	Small series of hexagonal flange bolts
6	AM-186FD-S06	Cylinder head stud bolt
7	AM-186FD-S07	Cylinder head stud bolt

# ENGINE DIAGRAM & PART LIST OF AM-186FD

## ENGINE ASSY - T

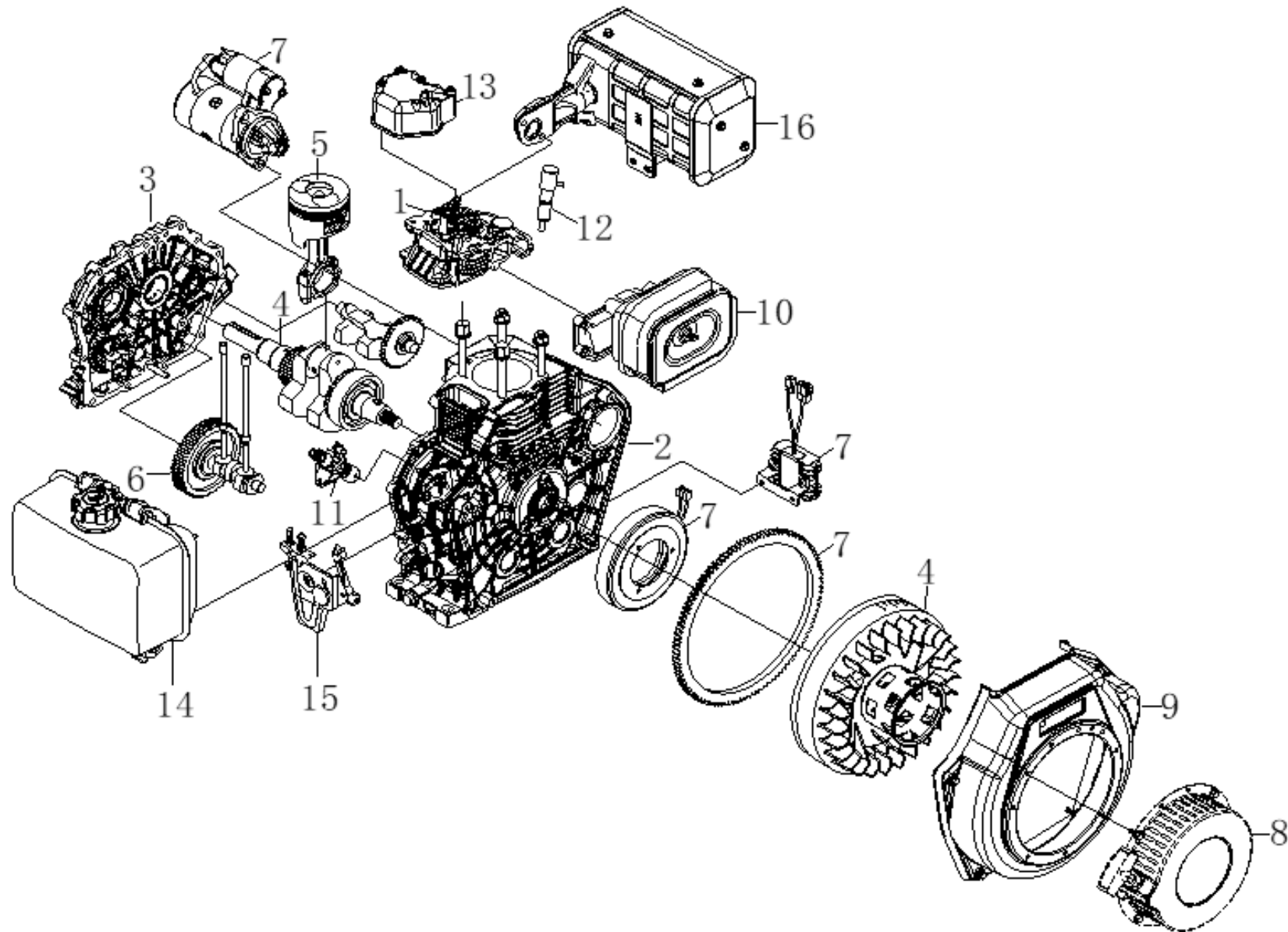

# ENGINE DIAGRAM & PART LIST OF AM-186FD

SL NO	PART NO	DESCRIPTION	SL NO	PART NO	DESCRIPTION
1	AM-186FD-T01	Cylinder Head Assy			
2	AM-186FD-T02	Crank case asyy			
3	AM-186FD-T03	Crank case cover Assy			
4	AM-186FD-T04	Crank-Fly Wheel Assy			
5	AM-186FD-T05	Piston-Connecting Rod Assy			
6	AM-186FD-T06	Camshaft Assy			
7	AM-186FD-T07	Flywheel And Generator Assy			
8	AM-186FD-T08	Start Cover Assy			
9	AM-186FD-T09	Wind scooper Assy			
10	AM-186FD-T10	Inlet Assy			
11	AM-186FD-T11	Oil Pump Assy			
12	AM-186FD-T12	Fuel Injection Assy			
13	AM-186FD-T13	Bonnet Assy			
14	AM-186FD-T14	Fuel Oil Assy			
15	AM-186FD-T15	Throttle Control Assy			
16	AM-186FD-T16	Exhaust Assy			

## INSPECTION & MAINTAINANCE

For safety use, make sure the machine is cleaned every three months. Before working, make sure to inspect the filter and the nozzle and ensure there is no impurity. After working, make sure there is no water in the pump and the hose.

If the machine needs to be repaired in the guarantee period, please return the machine to the shop. You need to provide the certificate of purchase on order to repair or get the substitute.

Before packing, the machine should be cleaned, then use closed packaging, packaging should be firm. Store the machine in dry place.

For transportation safety. The machine should comply with ISTA.





Do not dispose of electrical machines as unsorted municipal waste, use separate collection facilities.

If electrical machines are disposed of in landfills or dumps, hazardous substances can leak into the ground water and get into the food chain, damaging your health and well being.

When replacing old machines with new ones, the retailer is legally obligated to take back your old machine for disposals at least free of charge.

# WARRANTY CARD





## CUSTOMER COPY

DATE _____	DATE OF DELIVERY _____	DEALERS OFFICIAL SEAL	DEALERS SIGN _____
PURCHASERS NAME & ADDRESS _____ _____	 CUSTOMER SIGN		
PRODUCT NAME	PRODUCT SERIAL NO.	INVOICE/DN NO.	
			

I/Will accept the terms and conditions of warranty as in the warranty card

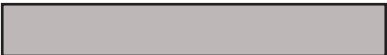
---





## DEALERS COPY

DATE _____	DATE OF DELIVERY _____	DEALERS OFFICIAL SEAL	DEALERS SIGN _____
PURCHASERS NAME & ADDRESS _____ _____	 CUSTOMER SIGN		
PRODUCT NAME	PRODUCT SERIAL NO.	INVOICE/DN NO.	
			

I/Will accept the terms and conditions of warranty as in the warranty card

---

## COMPANY COPY

DATE _____	DATE OF DELIVERY _____	DEALERS OFFICIAL SEAL	DEALERS SIGN _____
PURCHASERS NAME & ADDRESS _____ _____	 CUSTOMER SIGN		
PRODUCT NAME	PRODUCT SERIAL NO.	INVOICE/DN NO.	
			

I/Will accept the terms and conditions of warranty as in the warranty card

1. LIMITED WARRANTY PERIOD : For a period of six months from the date of Sale / delivery of the product which ever is earlier. 2. LIMITED WARRANTY OBLIGATION : Replacement of defective part(s) by authorized dealer are free of charges. If found defective by reasons of defective material / poor workmanship, parts will be replaced and there will be no value re-imburement. 3. TERMS & CONDITIONS : a. Claims under warranty will be accepted on submission of Warranty Card duly filled and stamped by authorized dealer together with the original purchase document. : b. Shipping / transportation / Incidental charges incurred in replacing defective parts under warranty shall be borne by the purchaser

WARRANTY null & void if

- (i) Lack of maintenance, (ii) Incorrect use of the machine or tampering, (iii) Use of non-genuine spare parts, (iv) Usage of acids, solvents, or any flammable materials, (v) Non-usage of filter water / clear water / soft water & using water above 40°C temperature, (vi) While using the pressure washers to draw water which is contaminated with dust & solvents (eg. paint thinners, gasoline, oil, etc.), (vii) Repair done by unauthorized service people, (viii) Those parts subject to wear & tear due to normal operations and plastic parts, rubber items etc, (ix) Loose connections, faulty electrical fixtures & fluctuations in power supply.
- 4. Should any failure occur during or after the warranty period, customer does not have the right to interrupt payment / price discount.
- 5. Incidental or consequential damages like inconvenience commercial loss, loss of tie, mental agony etc.
- 6. Loss of any nature due to operation or non-operation is not covered under warranty.
- 7. All free service are at Dealer's service point only.
- 8. Warranty ceases if service is not done periodically.
- 9. The attached card should be completed and returned to Ratnagiri Impex Pvt. Ltd. for registration immediately after sale / delivery.
- 10. The warranty is void unless you register the warranty card with Ratnagiri Impex Pvt. Ltd.
- 11. The decision of Ratnagiri Impex Pvt. Ltd., in settling the warranty is final in all respects.
- 12. All disputes are subject to Bangalore Courts Jurisdiction

1. LIMITED WARRANTY PERIOD : For a period of six months from the date of Sale / delivery of the product which ever is earlier. 2. LIMITED WARRANTY OBLIGATION : Replacement of defective part(s) by authorized dealer are free of charges. If found defective by reasons of defective material / poor workmanship, parts will be replaced and there will be no value re-imburement. 3. TERMS & CONDITIONS : a. Claims under warranty will be accepted on submission of Warranty Card duly filled and stamped by authorized dealer together with the original purchase document. : b. Shipping / transportation / Incidental charges incurred in replacing defective parts under warranty shall be borne by the purchaser.

WARRANTY null & void if

- (i) Lack of maintenance, (ii) Incorrect use of the machine or tampering, (iii) Use of non-genuine spare parts, (iv) Usage of acids, solvents, or any flammable materials, (v) Non-usage of filter water / clear water / soft water & using water above 40°C temperature, (vi) While using the pressure washers to draw water which is contaminated with dust & solvents (eg. paint thinners, gasoline, oil, etc.), (vii) Repair done by unauthorized service people, (viii) Those parts subject to wear & tear due to normal operations and plastic parts, rubber items etc, (ix) Loose connections, faulty electrical fixtures & fluctuations in power supply.
- 4. Should any failure occur during or after the warranty period, customer does not have the right to interrupt payment / price discount.
- 5. Incidental or consequential damages like inconvenience commercial loss, loss of tie, mental agony etc.
- 6. Loss of any nature due to operation or non-operation is not covered under warranty.
- 7. All free service are at Dealer's service point only.
- 8. Warranty ceases if service is not done periodically.
- 9. The attached card should be completed and returned to Ratnagiri Impex Pvt. Ltd. for registration immediately after sale / delivery.
- 10. The warranty is void unless you register the warranty card with Ratnagiri Impex Pvt. Ltd.
- 11. The decision of Ratnagiri Impex Pvt. Ltd., in settling the warranty is final in all respects.
- 12. All disputes are subject to Bangalore Courts Jurisdiction

1. LIMITED WARRANTY PERIOD : For a period of six months from the date of Sale / delivery of the product which ever is earlier. 2. LIMITED WARRANTY OBLIGATION : Replacement of defective part(s) by authorized dealer are free of charges. If found defective by reasons of defective material / poor workmanship, parts will be replaced and there will be no value re-imburement. 3. TERMS & CONDITIONS : a. Claims under warranty will be accepted on submission of Warranty Card duly filled and stamped by authorized dealer together with the original purchase document. : b. Shipping / transportation / Incidental charges incurred in replacing defective parts under warranty shall be borne by the purchaser.

WARRANTY null & void if

- (i) Lack of maintenance, (ii) Incorrect use of the machine or tampering, (iii) Use of non-genuine spare parts, (iv) Usage of acids, solvents, or any flammable materials, (v) Non-usage of filter water / clear water / soft water & using water above 40°C temperature, (vi) While using the pressure washers to draw water which is contaminated with dust & solvents (eg. paint thinners, gasoline, oil, etc.), (vii) Repair done by unauthorized service people, (viii) Those parts subject to wear & tear due to normal operations and plastic parts, rubber items etc, (ix) Loose connections, faulty electrical fixtures & fluctuations in power supply.
- 4. Should any failure occur during or after the warranty period, customer does not have the right to interrupt payment / price discount.
- 5. Incidental or consequential damages like inconvenience commercial loss, loss of tie, mental agony etc.
- 6. Loss of any nature due to operation or non-operation is not covered under warranty.
- 7. All free service are at Dealer's service point only.
- 8. Warranty ceases if service is not done periodically.
- 9. The attached card should be completed and returned to Ratnagiri Impex Pvt. Ltd. for registration immediately after sale / delivery.
- 10. The warranty is void unless you register the warranty card with Ratnagiri Impex Pvt. Ltd.
- 11. The decision of Ratnagiri Impex Pvt. Ltd., in settling the warranty is final in all respects.
- 12. All disputes are subject to Bangalore Courts Jurisdiction



**FREE SERVICE COUPON (30DAYS/30HRS. WHICHEVER IS EARLIER)**

MODEL

SERIAL NUMBER

PDI DATE

SERVICE NO.

PURCHASE BILL NO.

DATE

DEALERS OFFICE SEAL

- 1. Check and test the fuel mixture
- 3. Check , clean and adjust the spark plug
- 5. Check and sparken the cutting tools
- 7. Start and check the noise, vibration, loosen etc..

OPERATIONS

- 2. check and clean the air filter
- 4. Check and adjust the carburetor tuning
- 6. Product familirisation on usage
- 8. Routine maintenance and shortage.

**FREE SERVICE COUPON (30DAYS/30HRS. WHICHEVER IS EARLIER)**

MODEL

SERIAL NUMBER

PDI DATE

SERVICE NO.

PURCHASE BILL NO.

DATE

DEALERS OFFICE SEAL

- 1. Check and test the fuel mixture
- 3. Check , clean and adjust the spark plug
- 5. Check and sparken the cutting tools
- 7. Start and check the noise, vibration, loosen etc..

OPERATIONS

- 2. check and clean the air filter
- 4. Check and adjust the carburetor tuning
- 6. Product familirisation on usage
- 8. Routine maintenance and shortage.

**FREE SERVICE COUPON (30DAYS/30HRS. WHICHEVER IS EARLIER)**

MODEL

SERIAL NUMBER

PDI DATE

SERVICE NO.

PURCHASE BILL NO.

DATE

DEALERS OFFICE SEAL

- 1. Check and test the fuel mixture
- 3. Check , clean and adjust the spark plug
- 5. Check and sparken the cutting tools
- 7. Start and check the noise, vibration, loosen etc..

OPERATIONS

- 2. check and clean the air filter
- 4. Check and adjust the carburetor tuning
- 6. Product familirisation on usage
- 8. Routine maintenance and shortage.

# DOS

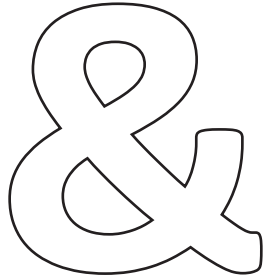

# DONT'S

1. Always read the instruction manual supplied along with the equipments and understand the correct installation and operating procedures before attempting to use the equipments.
2. It is important to use the personal protection equipments such as head helmet with visor, ear defenders, goggles, safety gloves, cut resistant shoes, trousers and jackets while operating potentially dangerous machines
3. Avoid untrained persons using the equipments. Children must not be allowed to handle these equipments
4. Always use genuine spares and accessories in repairs and usage to derive maximum life of the equipments.
5. Always keep the equipments in good working condition to minimize loss of output as well as to reduce the pollution and save the environment
6. Do not use the machine within range of persons unless they wear protective clothing
7. Do not operate the machine when fatigued or under the influence of alcohol or drugs
8. When the machine is running, please maintain a constant water supply. Without water circulation will damage the sealing rings of the machine.
9. For more query kindly contact for our Service Center/Dealer/ franchise

# Agrimate Army For Pest Control

ANY WHERE - ANY TIME - ANY CROP

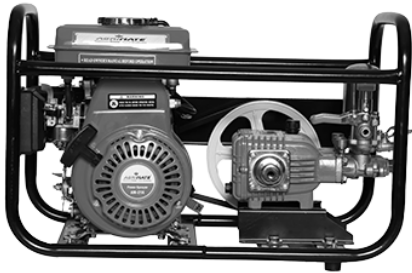
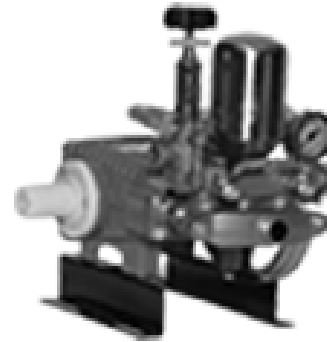

Marketed by:  
**ratnagiri  
impex**  
BRINGING YOU THE FUTURE... NOW

IMPORTED & MARKETED BY,  
**RATNAGIRI IMPEX PVT., LTD.,**

Annapurna House, #1 / 1G, 7th Cross, New  
Guddadahalli Mysore Road, Bangalore - 560 026

Missed Call : 7393 938 938 Email: [ask@agrimart.in](mailto:ask@agrimart.in)