

**AGRIMATE TEA PRUNER
AMTP-MC43-2S-NEO**

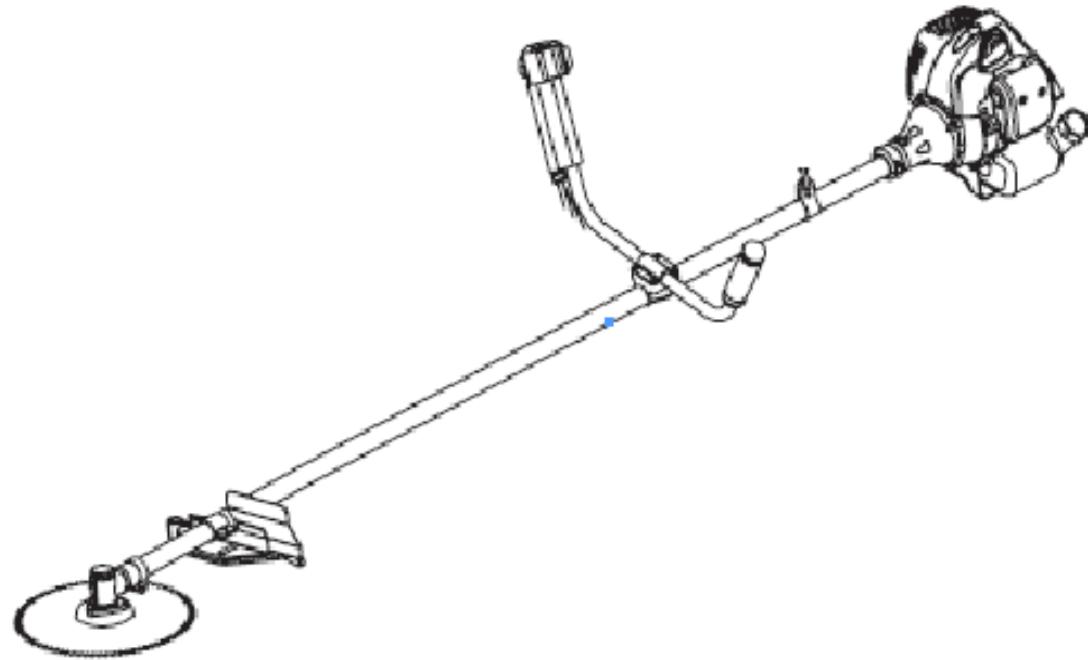

TECHNICAL SPECIFICATIONS

Model	AMTP-MC43-2S-NEO
Displacement	43CC
Power	1.27 KW
Tank Capacity	1.2 LTR

INTRODUCTION

Dear Sir/ Madam,

Thank you for choosing Agrimate product. You are the proud owner of high technology & durable machine. Trust that our Franchisee/Dealer installed the product & installed the product and explained you about the usage & service instructions. Please visit our autorised dealer for your future requirement of our other equipments, genuine spares, accessories and services. Service coupons are attached with this manual and you can avail free service to keep your machine fit always to use on demand.

About Ratnagiri,

We import and market of high quality of agriculture wide range of equipments which we are selling through our authorised franchisee or dealer network. We are in this field from past years service the farmer. community. For further details, Please visit our website www.agrimart.in. & Give a missed call to 7393 938 938.

GRAPHIC WARNINGS

Because a trimmer/cutter is a high-speed, fast cutting power tool, special safety precaution must be observed to reduce the risk of personal injury. Read this manual carefully. Be familiar with the controls and the proper use of the unit. Know how to shut it off, and how to unhook a harnessed unit quickly.



This graphic accompanied by the words warning and danger calls attention to an act or a condition which can lead to serious injury.



Wear safety boots



Wear safety gloves



READ & UNDERSTAND Operator's manual and safety manual.



Always wear eye and ear protection.



Wear head protection where there is a risk of falling objects



Always turn off engine and make sure the cutting tool has stopped before cleaning, removing or adjusting blade



Keep bystanders away at least 15m/50feet



WARNING! Never modify a trimmer or cutter in any way. improper use of any trimmer can cause serious or fatal personal injury.



WARNING! Do not touch hard wood; stone; steel.

SAFETY RULES & PRECAUTIONS

Proper safety precautions must be observed. Like all power equipment this unit must be handled carefully. Do not expose yourself or others to danger. Follow these general rules. Do not permit others to use this machine unless they are thoroughly responsible and have read, and understand the machine manual and are trained in its operation.

- Always wear safety goggles for eye protection. Dress properly , do not wear loose clothing or jewelry that could become caught in moving parts of the unit. Safe, sturdy, nonskid footwear should always be worn. Long hair should be tied back. It is recommended that legs and feet be covered to protect from flying debris during operation.
- Inspect the entire machine for loose parts (nuts, bolts, screws, etc.) and any damage. Repair or replace as necessary before using the machine.
- DO NOT USE any attachment with this power head other than the ones recommended by our company. Serious injury to the operator or bystanders could result as well as damage to the machine.
- Keep the handles away from oil and fuel.
- Always use proper handles and shoulder strap when cutting.
- Do not smoke while mixing fuel or filling tank.
- Do not mix fuel in an enclosed room or near open flames. Assure adequate ventilation. Always mix and store the fuel in a properly marked container that is approved by local codes and ordinances for such usage.
- Never remove the fuel tank cap while the engine is running.
- Never start or run the engine inside a closed room or building. Fumes from the exhaust contain dangerous carbon monoxide.
- Never attempt to make engine adjustments while the unit is running and strapped to the operator. Always make engine adjustments with the unit resting on a flat, clear surface.
- Do not use the unit if it is damaged or poorly adjusted. Never remove the machine's guard. Serious injury to the operator or bystanders could result as well as damage to the machine.
- Inspect the area to be cut and remove all debris that could become entangled in the nylon cutting head. Also remove any objects that the unit may throw during cutting.
- Keep children away. Onlookers should be kept at a safe distance from the work area, at least 15 METER. (50 FEET)
- Never leave the machine unattended.
- Do not use this unit for any job other than those for which it is intended as described in this manual.
- Do not overreach. Keep proper footing and balance at all times. Do not run the unit while standing on a ladder or on any other unstable footing location.
- Keep hands and feet clear of the nylon cutting head while unit is in use.

FOLLOW INSTRUCTION FOR CHANGING ACCESSORIES.

- Do not store in a closed area where fuel vapors can reach an open flame from hot water heaters, heaters, furnaces, etc. Store in a locked, well ventilated area only.
- ensure safe and proper performance of your product. These part are available from your dealer. The use of any other accessories or attachments may cause a potential hazard or injury to the user, damage to the machine and void this warranty.
- Clean the machine completely, especially, the fuel tank, its surroundings, and the air cleaner.
- When refueling, be sure to stop the engine and confirm that it is cooled down. Never refuel when the engine is running or hot. When gasoline spills, be sure to wipe it up completely and properly dispose of those materials before starting the engine.
- Stay clear of other workers or bystanders by at least 15 meters /50 feet.
- When ever approaching an operator of the machine, carefully call his attention and confirm that the operator stops the engine. Be careful not to startle or distract the operator which can cause an unsafe situation.
- Never touch the nylon cutting head when ever the engine is running. If it is necessary to adjust the protector or nylon cutting head, be sure to stop the engine and confirm that the nylon cutting head has stopped running.
- The engine should be turned off when the machine is moved between work areas.
- Be careful not to hit the nylon cutting head against stones, or the ground. Unreasonable rough operation will shorten the life of the machine as well as create an unsafe environment for yourself and those around you.
- Pay attention to loosening and overheating of parts. If there is any abnormality of the machine, stop operation immediately and check the machine carefully. If necessary, have the machine serviced by a authorized dealer. Never continue to operate a machine which may be malfunctioning.
- In start-up or during operation of the engine, never touch hot parts such as the muffler, the high voltage wire or the spark plug.
- After the engine has stopped, the muffler is still hot. Never place the machine in any places where there are flammable materials (dry grass, etc.), combustible gasses or combustible liquids.
- Pay special attention to operation in the rain or just after the rain as the ground may be slippery.
- If you slip or fall to the ground or into a hole, release the throttle lever immediately.
- Be careful not to drop the machine or hit it against obstacles. • Before proceeding to adjust or repair the machine, be sure to stop the engine and detach the spark plug cap from the spark plug.
- When the machine is placed in storage for a long time, drain fuel from the fuel tank and carburetor, clean the parts, move the machine to a safe place and confirm that the engine is cooled down.
- Make periodic inspections to assure safe and efficient operation. For a thorough inspection of your machine, please contact a dealer.
- Keep the machine away from fire or sparks.
- It is believed that a condition called Raynaud's phenomenon, which affects the fmgers of certain individuals may be brought about by exposure to vibration and cold. Exposure to vibration and cold may cause tingling and burning sensations followed by loss of color and numbness in the fingers. The following precautions are strongly recommended because the minimum exposure which might trigger the ailment is unknown. Keep your body warm, especially the head, neck, feet, ankles, hands and wrists. Maintain good blood circulation by performing vigorous arm exercises during frequent work breaks and also by not smoking.

TRANSMISSION DIAGRAM & SPARE PARTS LIST OF TEA PRUNER

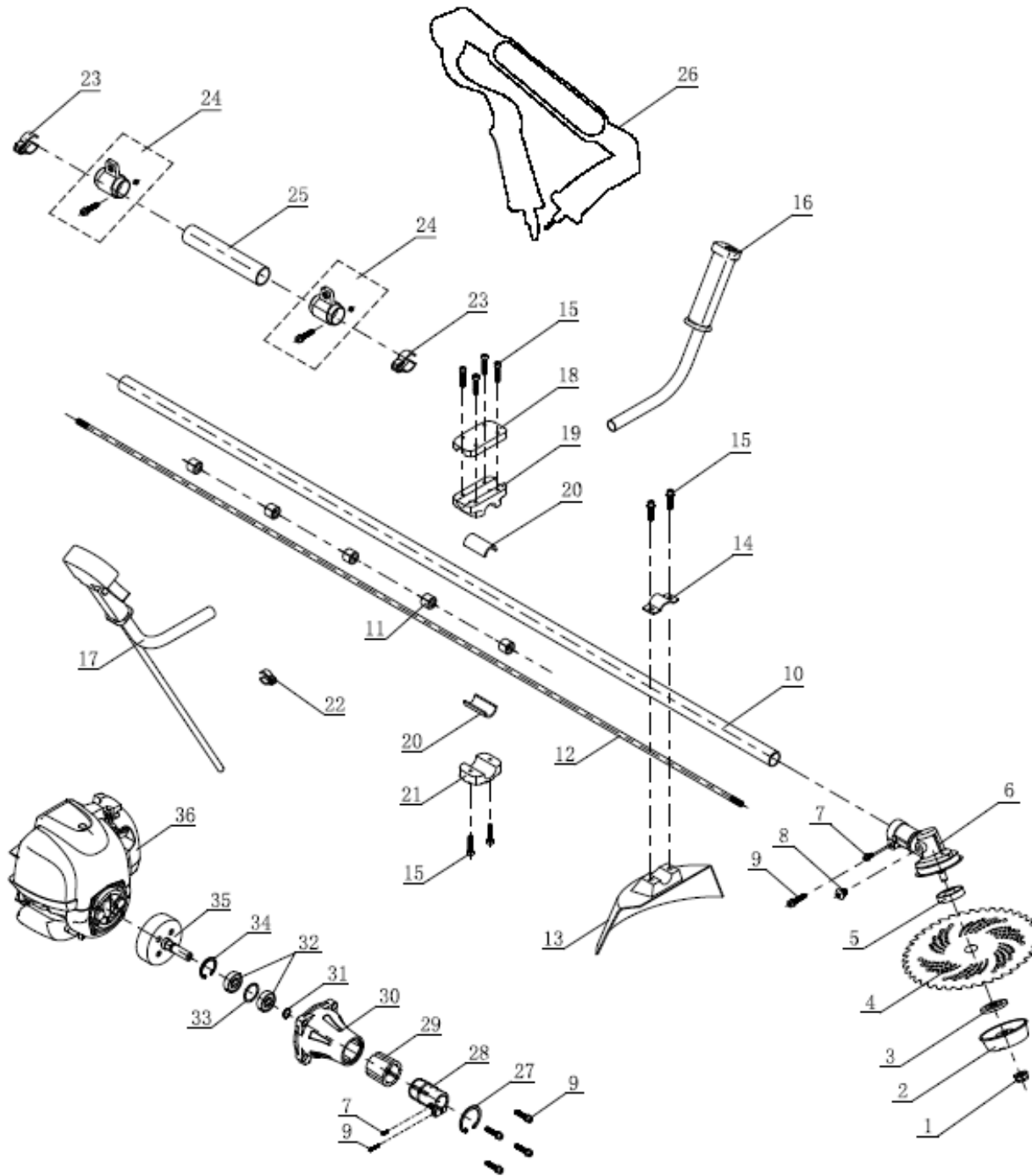

TRANSMISSION DIAGRAM & SPARE PARTS LIST OF TEA PRUNER

SL NO	PART NUMBER	DESCRIPTION	SL NO	PART NUMBER	DESCRIPTION
1	AMTP-MC43-NEO-T01	Lock nut	19	AMTP-MC43-NEO-T19	Middle handle base
2	AMTP-MC43-NEO-T02	Blade Sheild	20	AMTP-MC43-NEO-T20	Vibration reduce base
3	AMTP-MC43-NEO-T03	Press plate	21	AMTP-MC43-NEO-T21	Down handle base
4	AMTP-MC43-NEO-T04	3T Blade	22	AMTP-MC43-NEO-T22	Cable locker
5	AMTP-MC43-NEO-T05	Lock plate	23	AMTP-MC43-NEO-T23	Cable locker
6	AMTP-MC43-NEO-T06	Gear Box	24	AMTP-MC43-NEO-T24	Belt Mountings
7	AMTP-MC43-NEO-T07	Combined Screw	25	AMTP-MC43-NEO-T25	Spongy Sleeve
8	AMTP-MC43-NEO-T08	Round head screw	26	AMTP-MC43-NEO-T26	Belt
9	AMTP-MC43-NEO-T09	Combined Screw	27	AMTP-MC43-NEO-T27	Bead Flange
10	AMTP-MC43-NEO-T10	Shaft	28	AMTP-MC43-NEO-T28	Connecting Sleeve
11	AMTP-MC43-NEO-T11	Oil bearing	29	AMTP-MC43-NEO-T29	Rubber pad
12	AMTP-MC43-NEO-T12	Nine Teeth Shaft	30	AMTP-MC43-NEO-T30	Clutch housing
13	AMTP-MC43-NEO-T13	Grass guard	31	AMTP-MC43-NEO-T31	Shaft Flange
14	AMTP-MC43-NEO-T14	Press plate	32	AMTP-MC43-NEO-T32	Rolling bearing
15	AMTP-MC43-NEO-T15	Combined screw	33	AMTP-MC43-NEO-T33	Shim
16	AMTP-MC43-NEO-T16	Left Switch handle	34	AMTP-MC43-NEO-T34	Bead Flange
17	AMTP-MC43-NEO-T17	Right switch handle	35	AMTP-MC43-NEO-T35	Drum
18	AMTP-MC43-NEO-T18	Upper handle base	36	AMTP-MC43-NEO-T36	Engine

ENGINE DIAGRAM OF TEA PRUNER

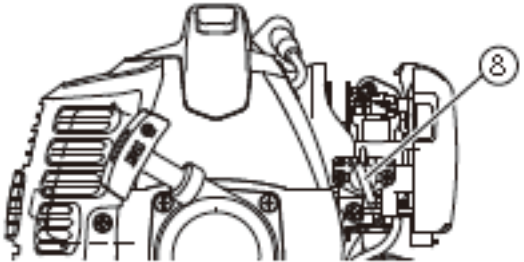
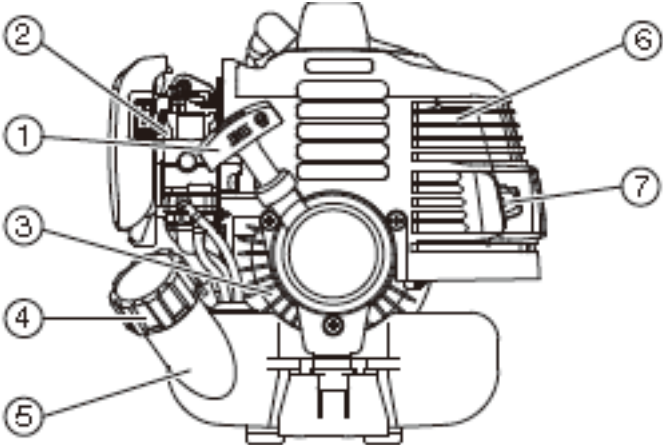
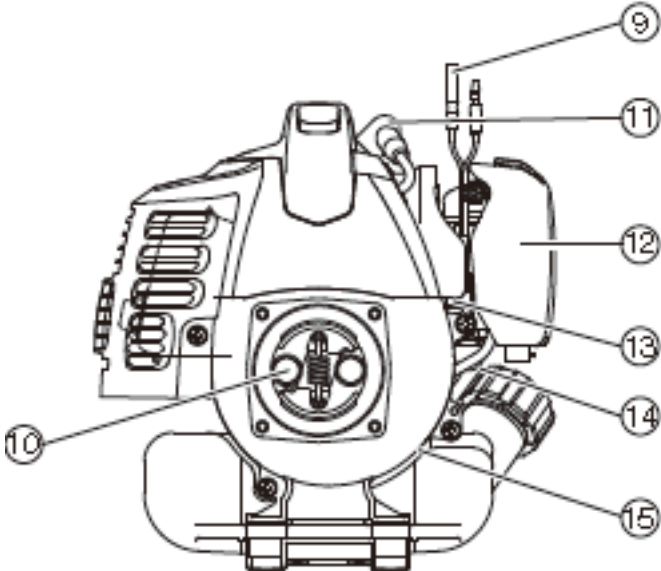
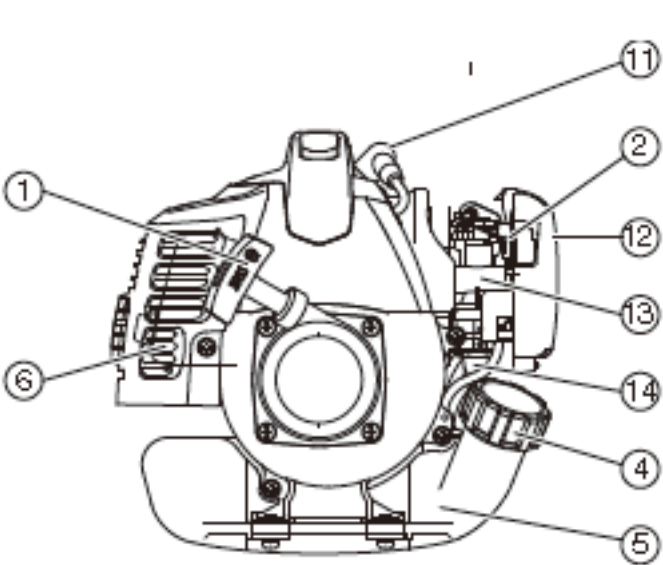

ENGINE SPARE PARTS LIST OF TEA PRUNER

SL NO	PART NUMBER	DESCRIPTION
1	AMTP-MC43-NEO-E01	Recoil starter grip
2	AMTP-MC43-NEO-E02	Choke lever
3	AMTP-MC43-NEO-E03	Cooling air inlet
4	AMTP-MC43-NEO-E04	Fuel tank cap
5	AMTP-MC43-NEO-E05	Fuel tank
6	AMTP-MC43-NEO-E06	Muffler
7	AMTP-MC43-NEO-E07	Exhaust port (Spark arrester)
8	AMTP-MC43-NEO-E08	Engine switch
9	AMTP-MC43-NEO-E09	Lead wire
10	AMTP-MC43-NEO-E10	Clutch
11	AMTP-MC43-NEO-E11	Ignition plug cap
12	AMTP-MC43-NEO-E12	Air cleaner
13	AMTP-MC43-NEO-E13	Carburetor
14	AMTP-MC43-NEO-E14	Priming button
15	AMTP-MC43-NEO-E15	Engine label

INSPECTION & MAINTAINANCE

For safety use, make sure the machine is cleaned every three months. Before working, make sure to inspect the filter and the nozzle and ensure there is no impurity. After working, make sure there is no water in the pump and the hose.

If the machine needs to be repaired in the guarantee period, please return the machine to the shop. You need to provide the certificate of purchase on order to repair or get the substitute.

Before packing, the machine should be cleaned, then use closed packaging, packaging should be firm. Store the machine in dry place.

For transportation safety. The machine should comply with ISTA.





Do not dispose of electrical machines as unsorted municipal waste, use separate collection facilities.

If electrical machines are disposed of in landfills or dumps, hazardous substances can leak into the ground water and get into the food chain, damaging your health and well being.

When replacing old machines with new ones, the retailer is legally obligated to take back your old machine for disposals at least free of charge.





WARRANTY CARD

CUSTOMER COPY

DATE _____	DATE OF DELIVERY _____	DEALERS OFFICIAL SEAL	DEALERS SIGN _____
PURCHASERS NAME & ADDRESS _____ _____	 CUSTOMER SIGN		
PRODUCT NAME	PRODUCT SERIAL NO.	INVOICE/DN NO.	
			

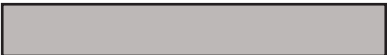



I/Will accept the terms and conditions of warranty as in the warranty card

DEALERS COPY

DATE _____	DATE OF DELIVERY _____	DEALERS OFFICIAL SEAL	DEALERS SIGN _____
PURCHASERS NAME & ADDRESS _____ _____	 CUSTOMER SIGN		
PRODUCT NAME	PRODUCT SERIAL NO.	INVOICE/DN NO.	
			

I/Will accept the terms and conditions of warranty as in the warranty card

COMPANY COPY

DATE _____	DATE OF DELIVERY _____	DEALERS OFFICIAL SEAL	DEALERS SIGN _____
PURCHASERS NAME & ADDRESS _____ _____	 CUSTOMER SIGN		
PRODUCT NAME	PRODUCT SERIAL NO.	INVOICE/DN NO.	
			

I/Will accept the terms and conditions of warranty as in the warranty card

1. LIMITED WARRANTY PERIOD : For a period of six months from the date of Sale / delivery of the product which ever is earlier. 2. LIMITED WARRANTY OBLIGATION : Replacement of defective part(s) by authorized dealer are free of charges. If found defective by reasons of defective material / poor workmanship, parts will be replaced and there will be no value re-imbusement. 3. TERMS & CONDITIONS : a. Claims under warranty will be accepted on submission of Warranty Card duly filled and stamped by authorized dealer together with the original purchase document. : b. Shipping / transportation / Incidental charges incurred in replacing defective parts under warranty shall be borne by the purchaser

WARRANTY null & void if

- (i) Lack of maintenance, (ii) Incorrect use of the machine or tampering, (iii) Use of non-genuine spare parts, (iv) Usage of acids, solvents, or any flammable materials, (v) Non-usage of filter water / clear water / soft water & using water above 40°C temperature, (vi) While using the pressure washers to draw water which is contaminated with dust & solvents (eg. paint thinners, gasoline, oil, etc.), (vii) Repair done by unauthorized service people, (viii) Those parts subject to wear & tear due to normal operations and plastic parts, rubber items etc, (ix) Loose connections, faulty electrical fixtures & fluctuations in power supply.
- 4. Should any failure occur during or after the warranty period, customer does not have the right to interrupt payment / price discount.
- 5. Incidental or consequential damages like inconvenience commercial loss, loss of tie, mental agony etc.
- 6. Loss of any nature due to operation or non-operation is not covered under warranty.
- 7. All free service are at Dealer's service point only.
- 8. Warranty ceases if service is not done periodically.
- 9. The attached card should be completed and returned to Ratnagiri Impex Pvt. Ltd. for registration immediately after sale / delivery.
- 10. The warranty is void unless you register the warranty card with Ratnagiri Impex Pvt. Ltd.
- 11. The decision of Ratnagiri Impex Pvt. Ltd., in settling the warranty is final in all respects.
- 12. All disputes are subject to Bangalore Courts Jurisdiction

1. LIMITED WARRANTY PERIOD : For a period of six months from the date of Sale / delivery of the product which ever is earlier. 2. LIMITED WARRANTY OBLIGATION : Replacement of defective part(s) by authorized dealer are free of charges. If found defective by reasons of defective material / poor workmanship, parts will be replaced and there will be no value re-imbusement. 3. TERMS & CONDITIONS : a. Claims under warranty will be accepted on submission of Warranty Card duly filled and stamped by authorized dealer together with the original purchase document. : b. Shipping / transportation / Incidental charges incurred in replacing defective parts under warranty shall be borne by the purchaser.

WARRANTY null & void if

- (i) Lack of maintenance, (ii) Incorrect use of the machine or tampering, (iii) Use of non-genuine spare parts, (iv) Usage of acids, solvents, or any flammable materials, (v) Non-usage of filter water / clear water / soft water & using water above 40°C temperature, (vi) While using the pressure washers to draw water which is contaminated with dust & solvents (eg. paint thinners, gasoline, oil, etc.), (vii) Repair done by unauthorized service people, (viii) Those parts subject to wear & tear due to normal operations and plastic parts, rubber items etc, (ix) Loose connections, faulty electrical fixtures & fluctuations in power supply.
- 4. Should any failure occur during or after the warranty period, customer does not have the right to interrupt payment / price discount.
- 5. Incidental or consequential damages like inconvenience commercial loss, loss of tie, mental agony etc.
- 6. Loss of any nature due to operation or non-operation is not covered under warranty.
- 7. All free service are at Dealer's service point only.
- 8. Warranty ceases if service is not done periodically.
- 9. The attached card should be completed and returned to Ratnagiri Impex Pvt. Ltd. for registration immediately after sale / delivery.
- 10. The warranty is void unless you register the warranty card with Ratnagiri Impex Pvt. Ltd.
- 11. The decision of Ratnagiri Impex Pvt. Ltd., in settling the warranty is final in all respects.
- 12. All disputes are subject to Bangalore Courts Jurisdiction

1. LIMITED WARRANTY PERIOD : For a period of six months from the date of Sale / delivery of the product which ever is earlier. 2. LIMITED WARRANTY OBLIGATION : Replacement of defective part(s) by authorized dealer are free of charges. If found defective by reasons of defective material / poor workmanship, parts will be replaced and there will be no value re-imbusement. 3. TERMS & CONDITIONS : a. Claims under warranty will be accepted on submission of Warranty Card duly filled and stamped by authorized dealer together with the original purchase document. : b. Shipping / transportation / Incidental charges incurred in replacing defective parts under warranty shall be borne by the purchaser.

WARRANTY null & void if

- (i) Lack of maintenance, (ii) Incorrect use of the machine or tampering, (iii) Use of non-genuine spare parts, (iv) Usage of acids, solvents, or any flammable materials, (v) Non-usage of filter water / clear water / soft water & using water above 40°C temperature, (vi) While using the pressure washers to draw water which is contaminated with dust & solvents (eg. paint thinners, gasoline, oil, etc.), (vii) Repair done by unauthorized service people, (viii) Those parts subject to wear & tear due to normal operations and plastic parts, rubber items etc, (ix) Loose connections, faulty electrical fixtures & fluctuations in power supply.
- 4. Should any failure occur during or after the warranty period, customer does not have the right to interrupt payment / price discount.
- 5. Incidental or consequential damages like inconvenience commercial loss, loss of tie, mental agony etc.
- 6. Loss of any nature due to operation or non-operation is not covered under warranty.
- 7. All free service are at Dealer's service point only.
- 8. Warranty ceases if service is not done periodically.
- 9. The attached card should be completed and returned to Ratnagiri Impex Pvt. Ltd. for registration immediately after sale / delivery.
- 10. The warranty is void unless you register the warranty card with Ratnagiri Impex Pvt. Ltd.
- 11. The decision of Ratnagiri Impex Pvt. Ltd., in settling the warranty is final in all respects.
- 12. All disputes are subject to Bangalore Courts Jurisdiction



FREE SERVICE COUPON (30DAYS/30HRS. WHICHEVER IS EARLIER)

MODEL

SERIAL NUMBER

PDI DATE

SERVICE NO.

PURCHASE BILL NO.

DATE

DEALERS OFFICE SEAL

- 1. Check and test the fuel mixture
- 3. Check , clean and adjust the spark plug
- 5. Check and sparken the cutting tools
- 7. Start and check the noise, vibration, loosen etc..

OPERATIONS

- 2. check and clean the air filter
- 4. Check and adjust the carburetor tuning
- 6. Product familirisation on usage
- 8. Routine maintenance and shortage.

FREE SERVICE COUPON (30DAYS/30HRS. WHICHEVER IS EARLIER)

MODEL

SERIAL NUMBER

PDI DATE

SERVICE NO.

PURCHASE BILL NO.

DATE

DEALERS OFFICE SEAL

- 1. Check and test the fuel mixture
- 3. Check , clean and adjust the spark plug
- 5. Check and sparken the cutting tools
- 7. Start and check the noise, vibration, loosen etc..

OPERATIONS

- 2. check and clean the air filter
- 4. Check and adjust the carburetor tuning
- 6. Product familirisation on usage
- 8. Routine maintenance and shortage.

FREE SERVICE COUPON (30DAYS/30HRS. WHICHEVER IS EARLIER)

MODEL

SERIAL NUMBER

PDI DATE

SERVICE NO.

PURCHASE BILL NO.

DATE

DEALERS OFFICE SEAL

- 1. Check and test the fuel mixture
- 3. Check , clean and adjust the spark plug
- 5. Check and sparken the cutting tools
- 7. Start and check the noise, vibration, loosen etc..

OPERATIONS

- 2. check and clean the air filter
- 4. Check and adjust the carburetor tuning
- 6. Product familirisation on usage
- 8. Routine maintenance and shortage.

DOS

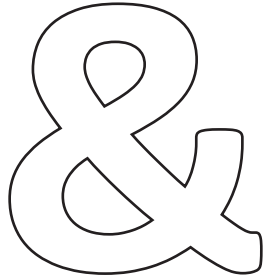

DONTs

1. Always read the instruction manual supplied along with the equipments and understand the correct installation and operating procedures before attempting to use the equipments.
2. It is important to use the personal protection equipments such as head helmet with visor, ear defenders, goggles, safety gloves, cut resistant shoes, trousers and jackets while operating potentially dangerous machines
3. Avoid untrained persons using the equipments. Children must not be allowed to handle these equipments
4. Always use genuine spares and accessories in repairs and usage to derive maximum life of the equipments.
5. Always keep the equipments in good working condition to minimize loss of output as well as to reduce the pollution and save the environment
6. Do not use the machine within range of persons unless they wear protective clothing
7. Do not operate the machine when fatigued or under the influence of alcohol or drugs
8. When the machine is running, please maintain a constant water supply. Without water circulation will damage the sealing rings of the machine.
9. For more query kindly contact for our Service Center/Dealer/ franchise

Agrimate Army For Pest Control

ANY WHERE - ANY TIME - ANY CROP

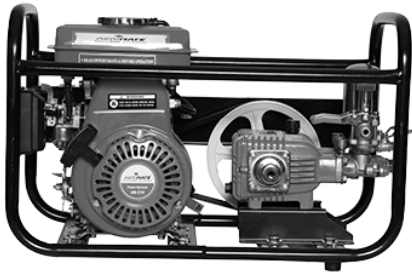
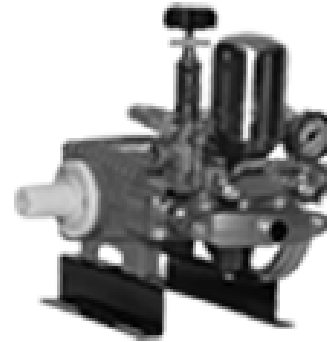

Marketed by:
**ratnagiri
impex**
BRINGING YOU THE FUTURE... NOW

IMPORTED & MARKETED BY,
RATNAGIRI IMPEX PVT., LTD.,

Annapurna House, #1 / 1G, 7th Cross, New
Guddadahalli Mysore Road, Bangalore - 560 026

Missed Call : 7393 938 938 Email: ask@agrimart.in